

TM Mobile Workstation Manual



This Manual contains information of the Techman Robot product series (hereinafter referred to as the TM Robot). The information contained herein is the property of Techman Robot Inc. (hereinafter referred to as the Corporation) and shall not be reproduced in whole or in part without prior authorization from the Corporation. No information contained herein shall be considered an offer or commitment. The information herein is subject to change without notice. The document is periodically reviewed and revised. The Corporation assumes no responsibility for any errors or omissions in the documentation.

TM logo is registered trademark of TECHMAN ROBOT INC. in Taiwan and other countries and the Corporation reserves the ownership of this manual and its copy and its copyrights.

1. Product Function and Specification	5
1.1 Function	5
1.2 Specification.....	5
1.3 Three-view Diagram.....	6
1.4 Flange Surface.....	6
2. Packing List.....	7
3. Installation	9
3.1 Control Box Installation	9
3.2 Robot Arm Installation.....	12
3.3 TM Mobile Workstation Application.....	13
3.4 Casters Setting	13
3.5 Terminal Block Wiring	14

Revision History Table

Revision	Date	Revised Content
01	October 2018	Original release
02	June 2019	Revise quantity of M4L6 screw & update Packing List

1. Product Function and Specification

1.1 Function

TM Mobile Workstation is a convenient tool for users to organize and store the TM Robot, the control box and other components. Users can move the TM Mobile Workstation with the TM Robot to different work cells for easy and flexible deployment.

1.2 Specification

Depth	729mm
Width	700mm
Height	800mm
Weight	110kg
Applicable Robot	TM5-700/TM5-900
Max. Recommended* Profile(TM5-700/TM5-900):	Up to 80% of the max speed with the half max payload and default acceleration rate (500ms for Time to top speed).

*Max. Recommended profile is highly relevant to pose/motion/acceleration and the characteristics of the ground surface.



WARNING:

1. Before installing and using this product, the user must first perform a risk assessment based on the conditions of use.
2. Due to its high center of gravity, the stability of the TM Mobile Workstation is largely affected by robot kinematics (including velocity, acceleration and poses) and the environment (including characteristics of the floor surface and structure).
3. The recommended maximum operating conditions and related data about the product can't be mistakenly regarded as the guarantee of the Corporation.
4. Operating the product without properly evaluating at risks, testing, and carefully reading the product's operating manual, the product would dump or pinch to the users, even cause the life-threatening dangers.
5. Failure to perform a proper risk assessment or comply with the TM product manuals may increase the risk of injury or death.

1.3 Three-view Diagram

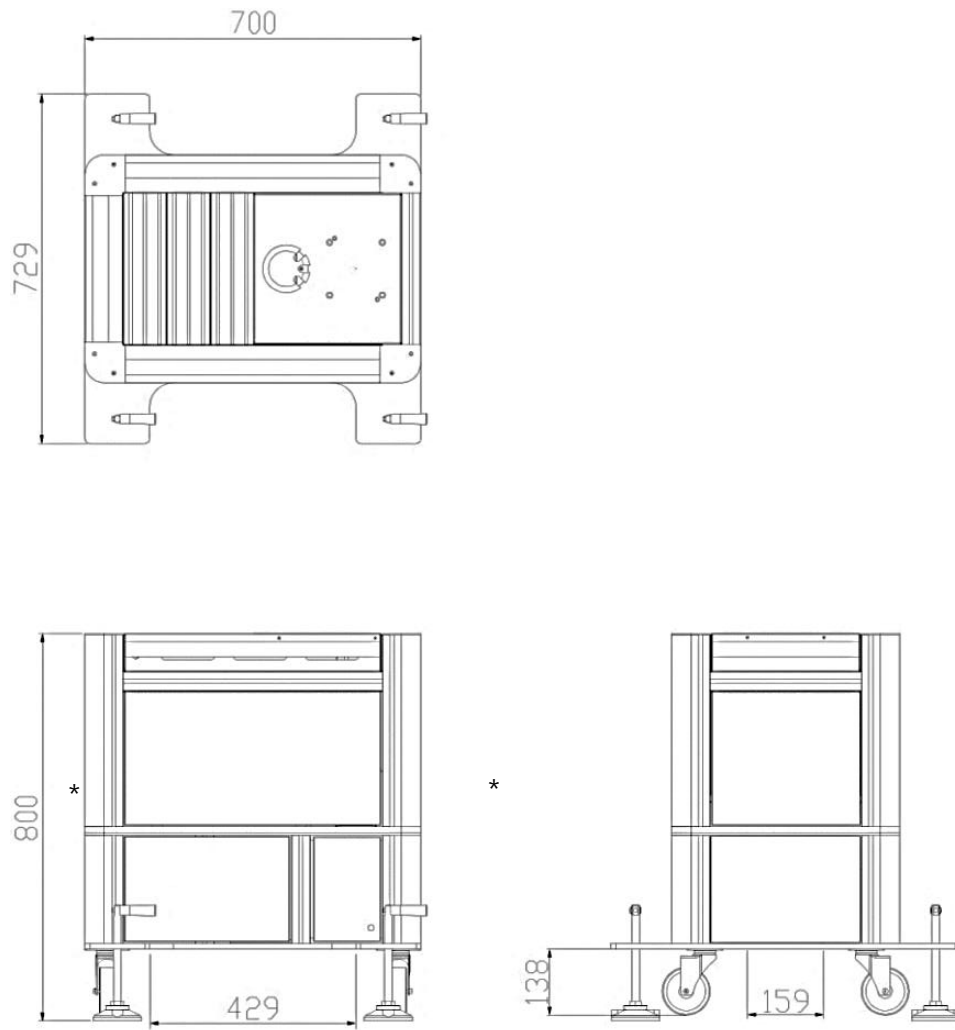

* The distances have deducted the wheel range.

1.4 Flange Surface

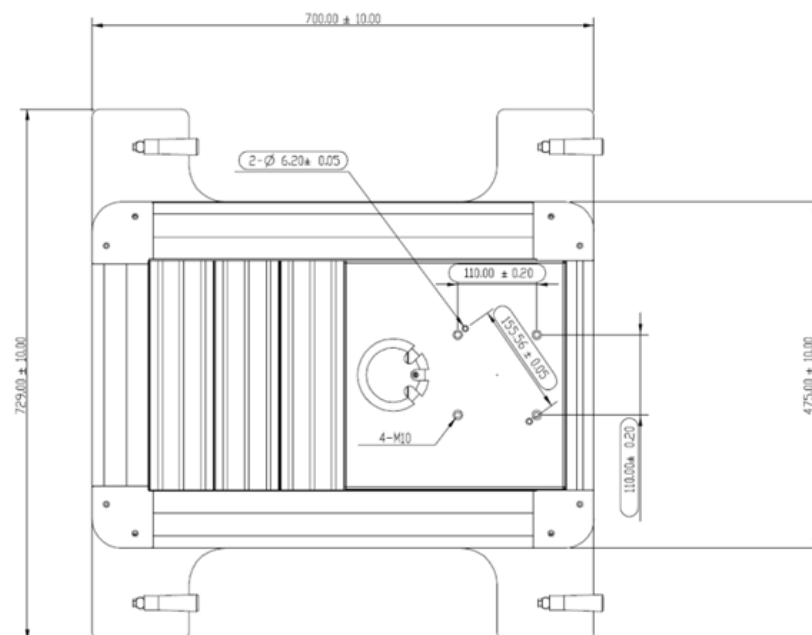

2. Packing List

TM Mobile Workstation comes with a TM Mobile Workstation and a box packaging with the following items:



1 x Power Cord* with rating of 16A
300V and length of 1830±5mm



6 x M4*6mm Flat Screw



10 x M4*6mm Combination
Flanged-Hex/Phillips-Head Screw



2 x Rail



2 x Bracket A
(4 holes)



2 x Bracket B
(3 holes)



1 x Desktop Cover



4 x M10*30mm Screw
4 x Washer



2 x Handle

*This power cord comes with the type B plug at one end and the IEC 60320 C-13 connector at the other end mainly used in Taiwan, Japan, and North America. To compatible with the plugs and sockets regulated by your local governments, it is recommend to use the power cord comes with the TM Mobile Workstation to connect between control box and TM Mobile Workstation and use the power cord comes with TM Robot for external power.

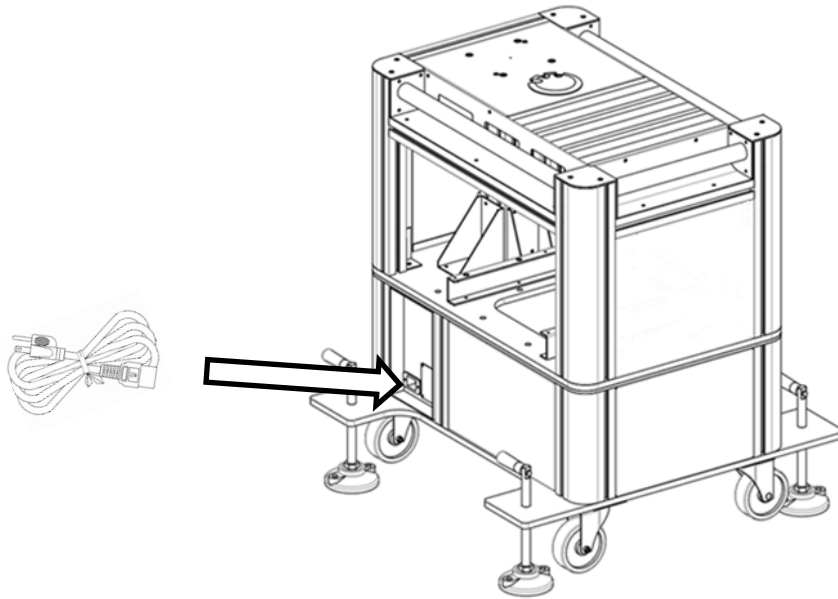

Follow the arrow in the picture to plug in Power Cord

3. Installation

3.1 Control Box Installation

1. Remove the hand grips and the foot stands.

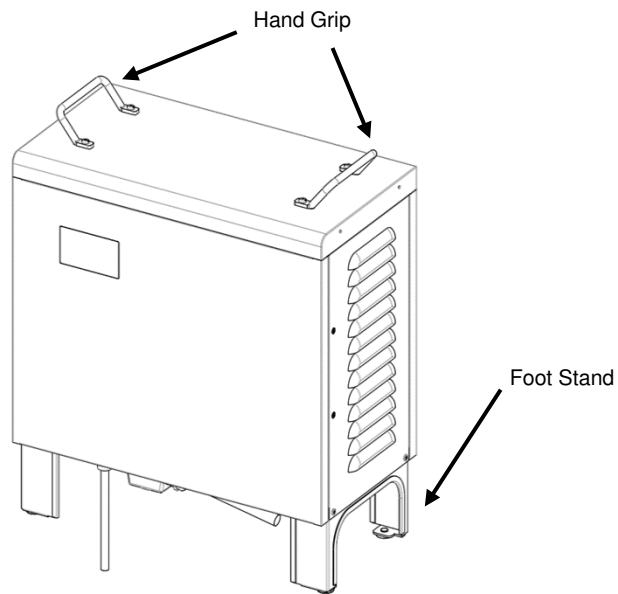

Positions to Detach the Hand Grip

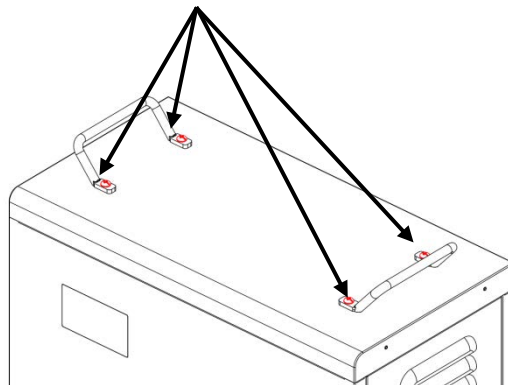

Positions to Detach the Foot Stand

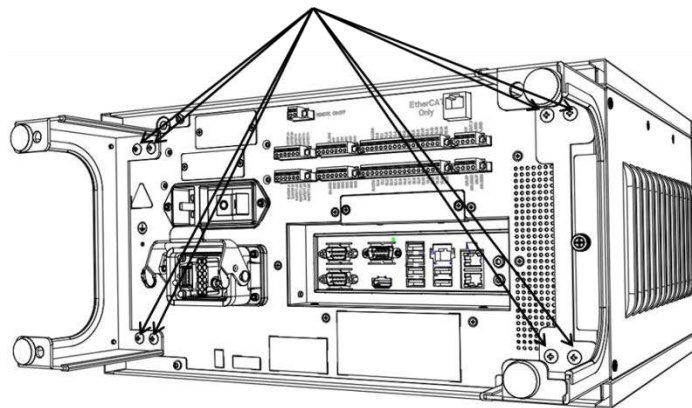

2. Mount both of the Rails on the braces inside of the TM Mobile Workstation with M4*6mm Flat Screws to the respective holes as shown.

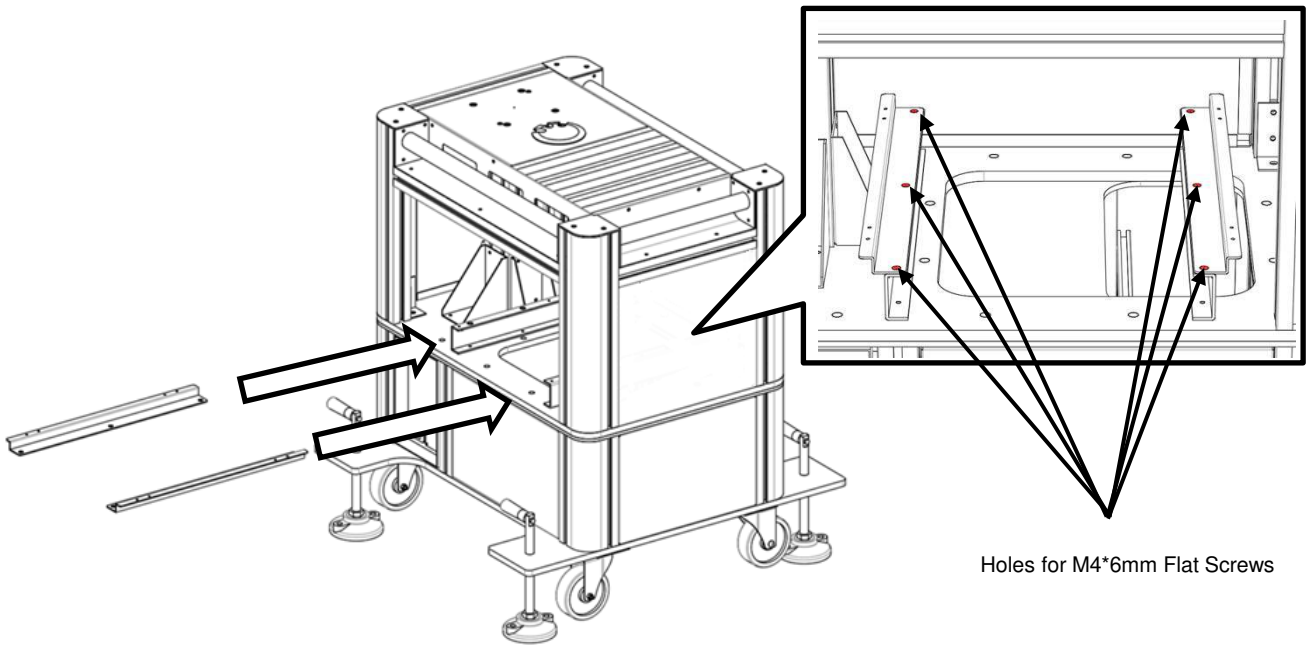

3. Put the control box on both of Rails of the TM Mobile Workstation as shown below, and then secure the control box with both of Brackets A, both of Brackets B, M4*6mm Combination Flanged-Hex/Phillips-Head Screws, and the screws removed from the hand grips. You can press the left side of the side panel to open it and tighten the screws better, and leave it opened for cable routing such as the Ethernet cable.

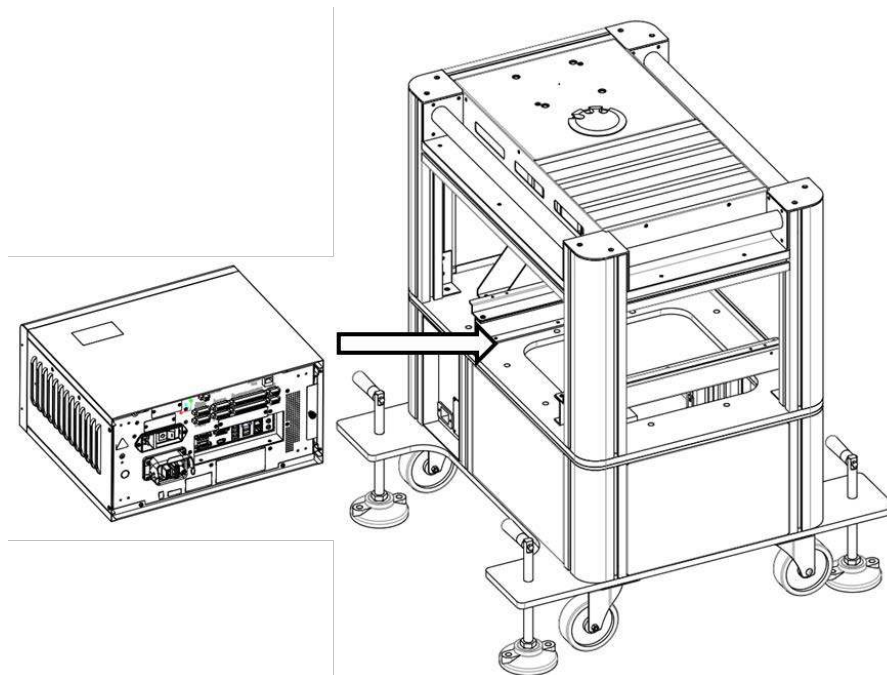

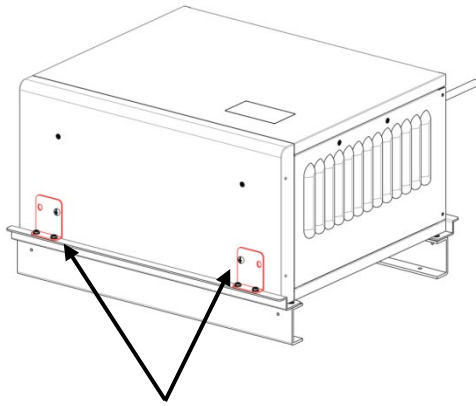

Bracket A

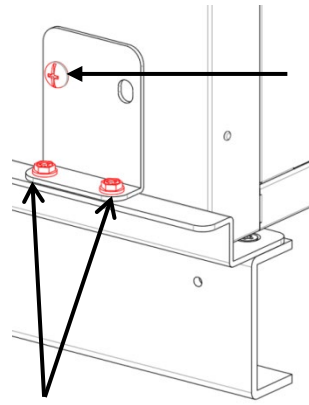

The screw removed from the hand grips

M4*6mm Combination

Flanged-Hex/Phillips-Head Screw

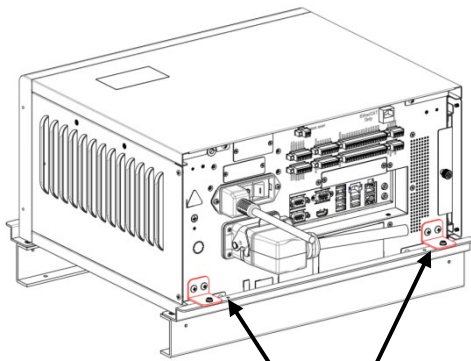

Bracket B

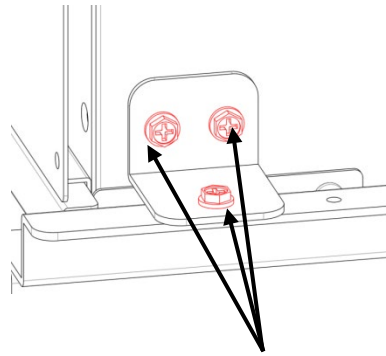

M4*6mm Combination

Flanged-Hex/Phillips-Head Screw

3.2 Robot Arm Installation

1. Orient cable of the robot towards the cord hole.
2. Secure TM robot with M10 screws and washers.

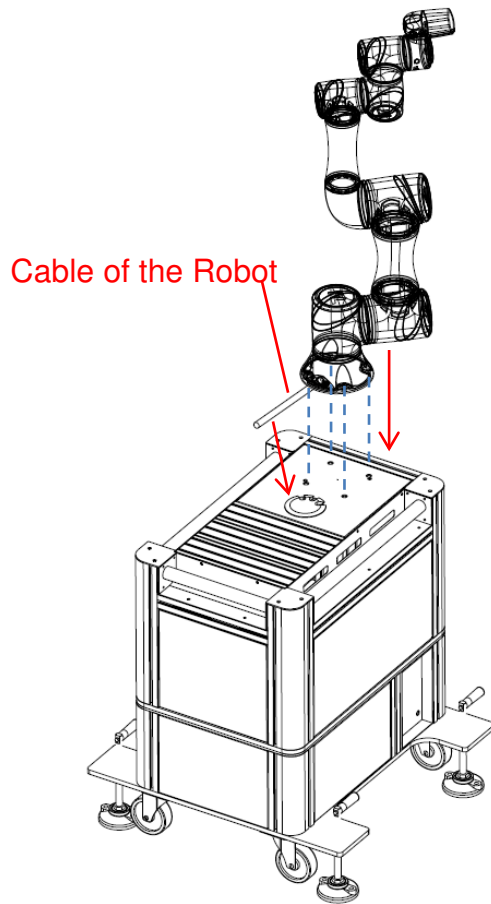

3. Pass cable of the robot through the cord hole and connect to control box, and cover the cord hole with desktop cover.

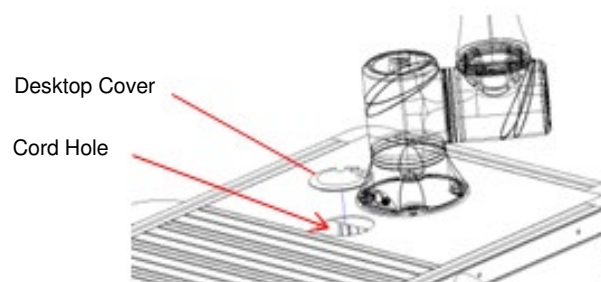

3.3 TM Mobile Workstation Application

1. You can put insertion stopper nuts into the slots at the top of the TM Mobile Workstation, and thread your application with bolts together on the nuts. The recommended thread nominal of the insertion stopper nuts come with the dimension of 10mm x 5mm is M5 or M6.

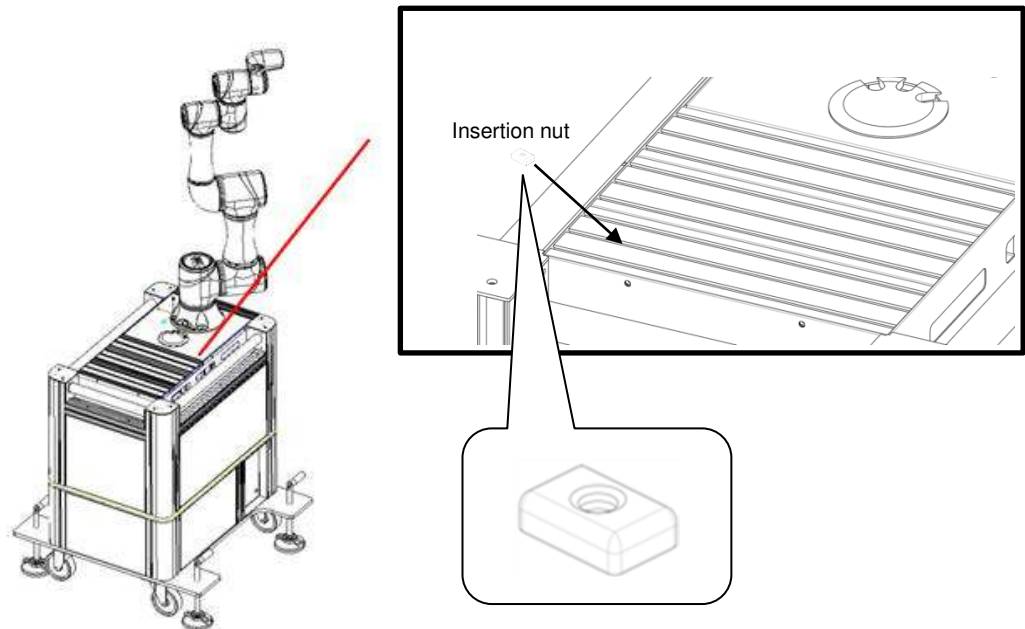

3.4 Casters Setting

- To move the TM Mobile Workstation: Turn the handles counterclockwise until the casters touch the ground.
- To fix the TM Mobile Workstation: Turn the handles clockwise until the casters are lifted off the ground.

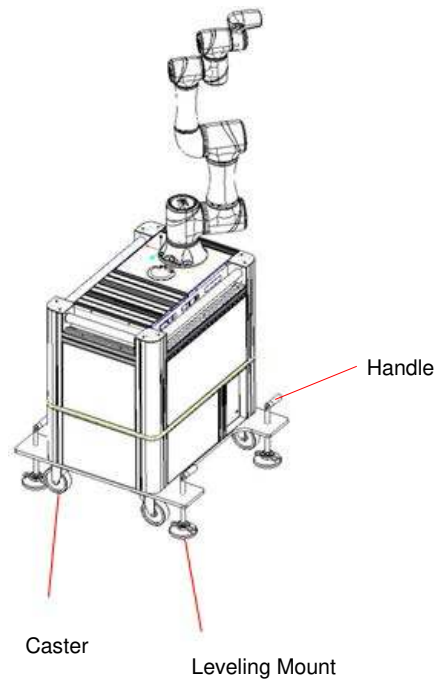

3.5 Terminal Block Wiring

- After shutting down the control box and turning off the circuit breaker, connect L2, N2, and PE with the extension cord.

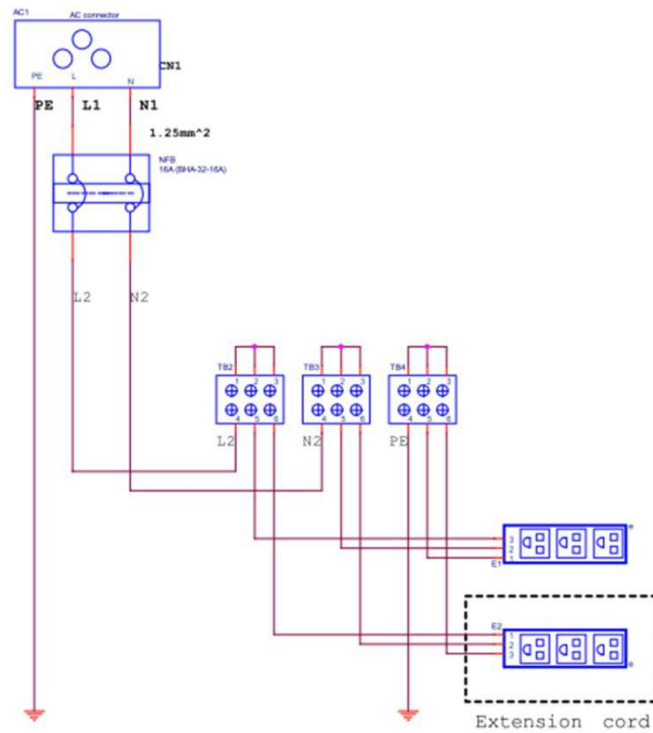
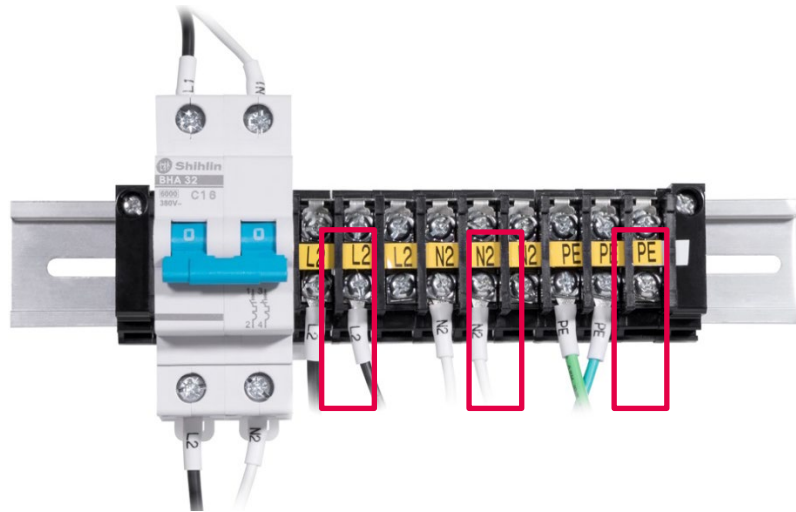

- Turn on the circuit breaker.

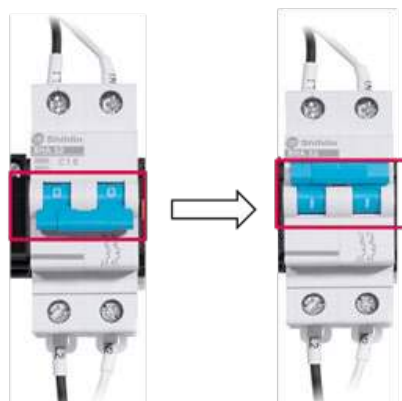

OMRON Corporation Industrial Automation Company
Kyoto, JAPAN

Contact: www.ia.omron.com

Regional Headquarters

OMRON EUROPE B.V.

Wegalaan 67-69, 2132 JD Hoofddorp
The Netherlands
Tel: (31)2356-81-300/Fax: (31)2356-81-388

OMRON ASIA PACIFIC PTE. LTD.

No. 438A Alexandra Road # 05-05/08 (Lobby 2),
Alexandra Technopark,
Singapore 119967
Tel: (65) 6835-3011/Fax: (65) 6835-2711

OMRON ELECTRONICS LLC

2895 Greenspoint Parkway, Suite 200 Hoffman Estates,
IL 60169 U.S.A.
Tel: (1) 847-843-7900/Fax: (1) 847-843-7787

OMRON ADEPT TECHNOLOGIES, INC.

4550 Norris Canyon Road, Suite 150, San Ramon, CA 94583 U.S.A.
Tel: (1) 925-245-3400/Fax: (1) 925-960-0590

OMRON (CHINA) CO., LTD.

Room 2211, Bank of China Tower, 200 Yin Cheng Zhong Road,
PuDong New Area, Shanghai, 200120, China
Tel: (86) 21-5037-2222/Fax: (86) 21-5037-2200

Authorized Distributor:

© Techman Robot Inc. 2019 All Rights Reserved.
In the interest of product improvement,
specifications are subject to change without notice.

Cat. No. I628-E-02

0619 (1018)