



## STEVAL-IFS015V1

### Smart monitoring node based on the STM32F103xx and LIS331DLH

Data brief

#### Features

- Low data rate wireless (ZigBee®) implementation
- Displays multiple sensor parameters for itself and also the other wireless nodes associated to it in star network
- MEMS, temperature, resistive, humidity, light intensity sensors
- Manual or programmable control of nodes from the station
- TFT display with touchscreen menu navigation
- GUI for logged data reading, saving and analysis using graphs
- Rechargeable Li-ion battery. Operation possible without battery also using mini-USB to power up the system

#### Description

The system, called smart monitoring station, is a handheld device which works as the hub for low data rate wireless network based on ZigBee® protocol to which all the nodes (smart monitoring nodes - STEVAL-IFS015V1) are connected. This system measures the temperature, humidity and light intensity and gathers information of various sensors (temperature, humidity, light intensity and MEMS) from nodes placed at different locations. It can also configure the alarm thresholds for the parameters of all the connected nodes, as well as for itself. Lights (or any other AC load) connected to nodes may be controlled through the smart monitoring station with addition of a few components and its status is available on the smart monitoring station display.

The system has a user interface with the graphic menu, color TFT display (240 x 320) and touchscreen. Data logging and analysis of logged data can be done using the GUI developed for this system.



This demonstration board can be powered up using 3.7 V Li-ion battery. Alternatively it can work with USB power without battery. When the battery is mounted, the same USB charges the battery and operates the system.

# 1 Circuits schematics

Figure 1. Power supply

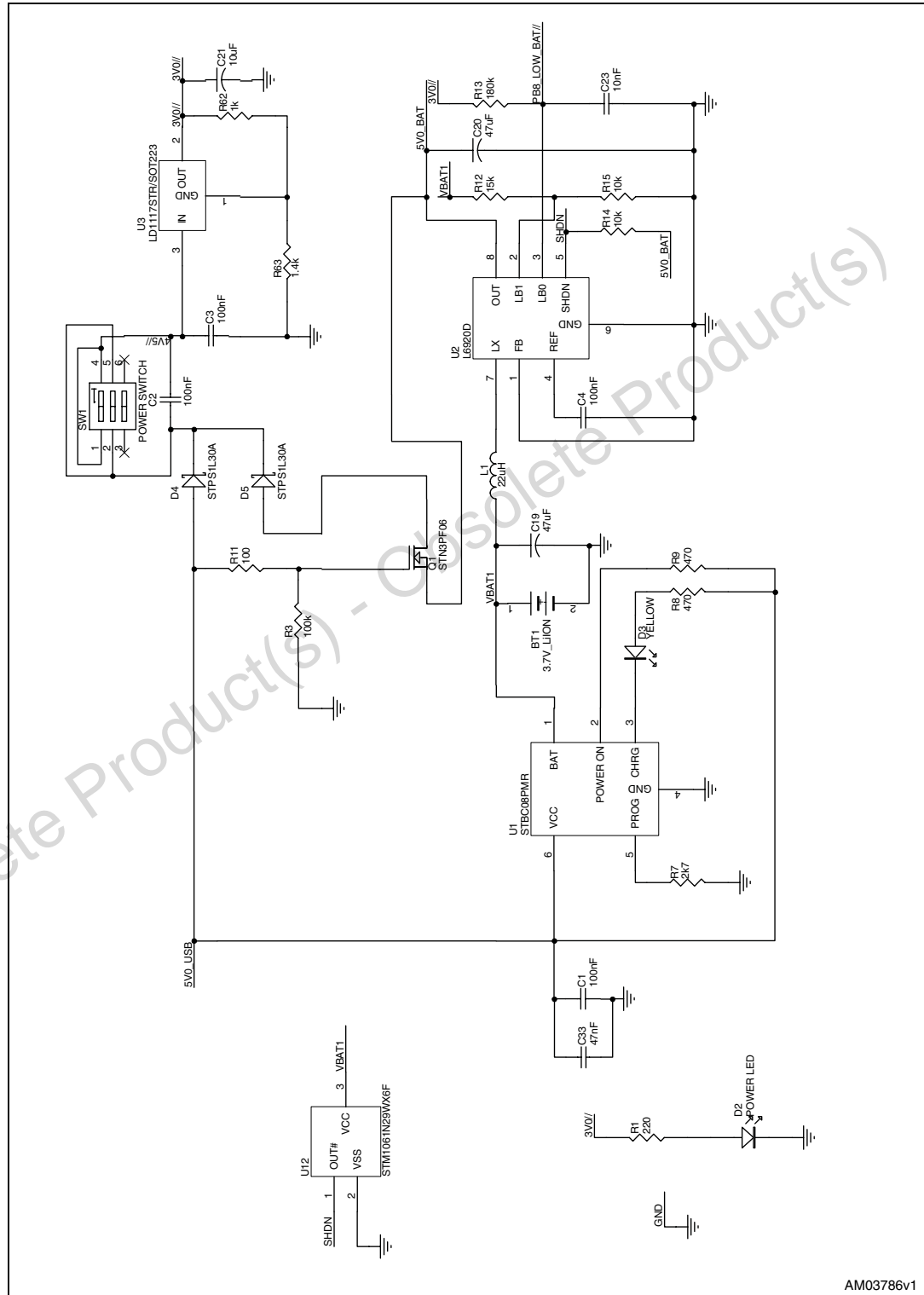

AM03786V1

Figure 2. Connectors - ZigBee®, microSD and JTAG

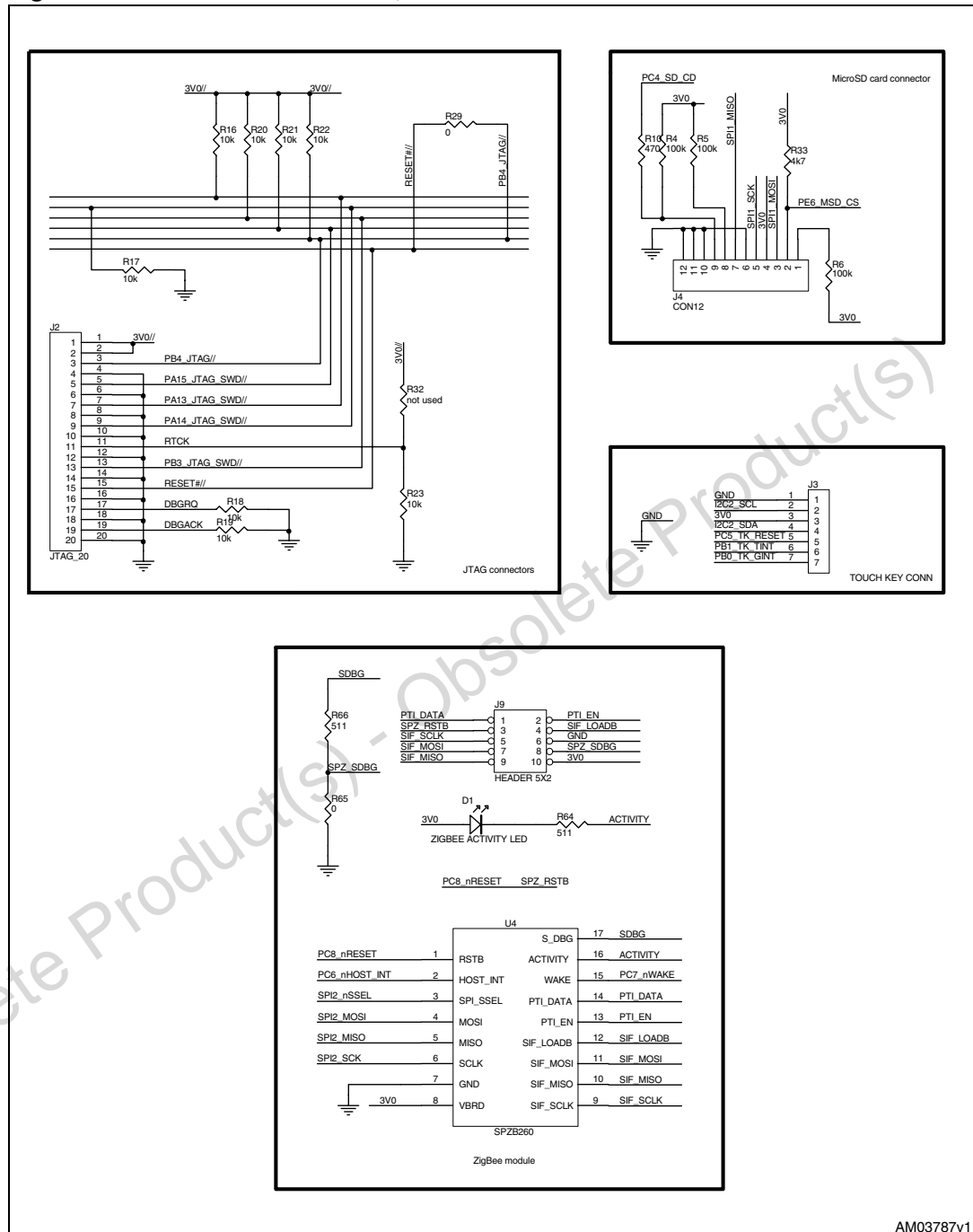

AM03787v1

Figure 3. TFT displays, MEMS, memory and sensors

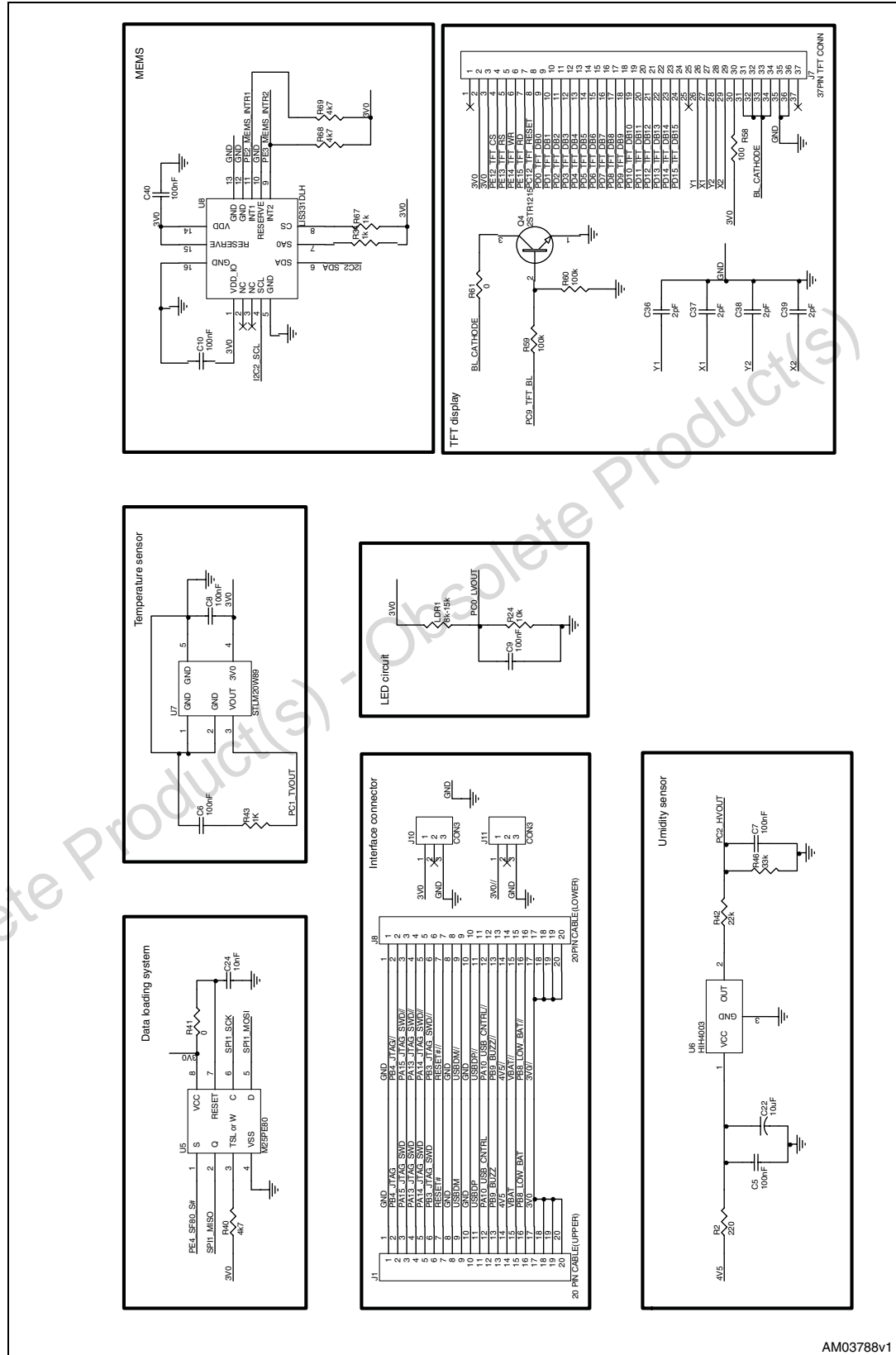

AM03788v1

Figure 4. Microcontroller

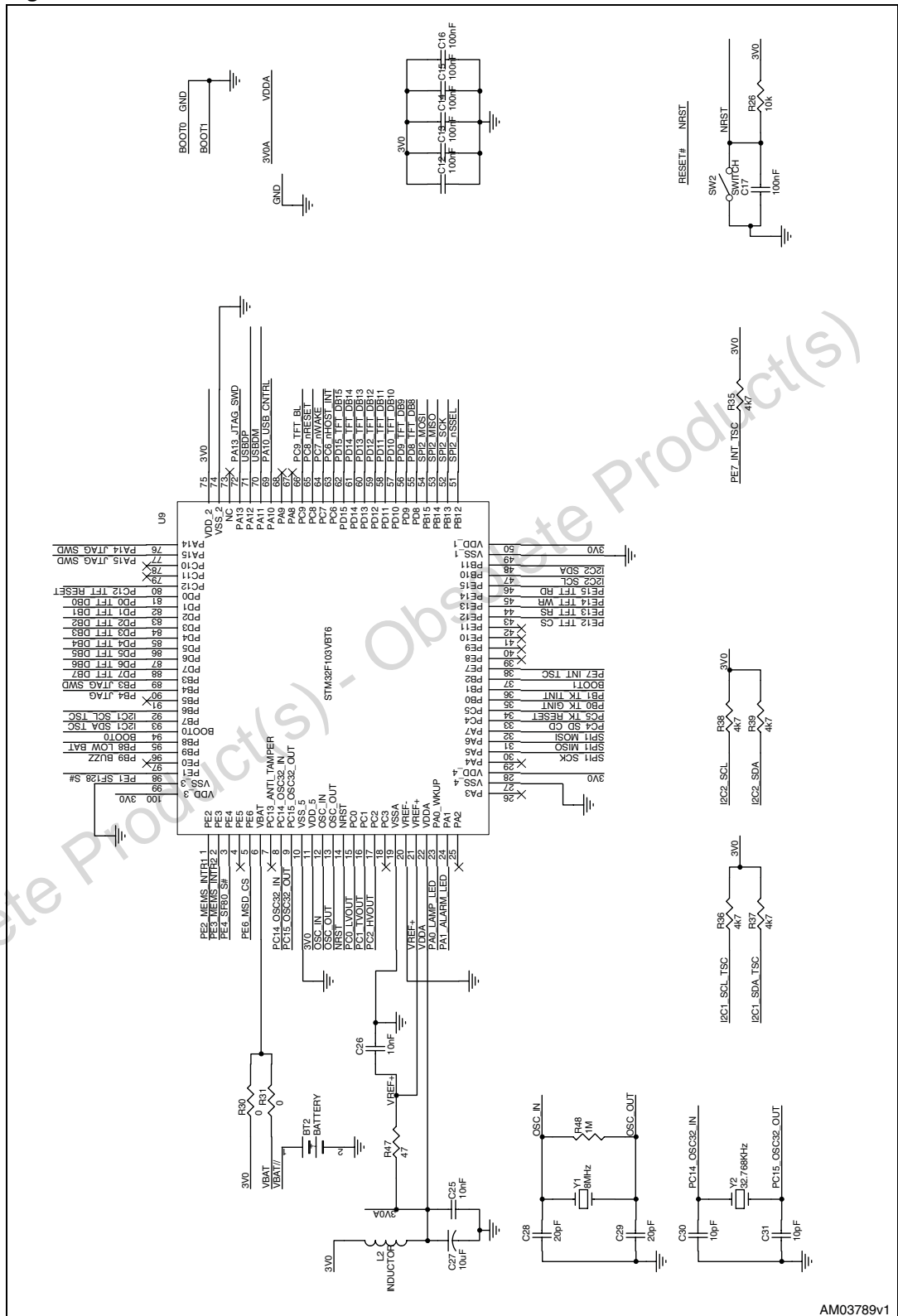

AM03789v1

Figure 5. USB, touchscreen controller, buzzer and memory

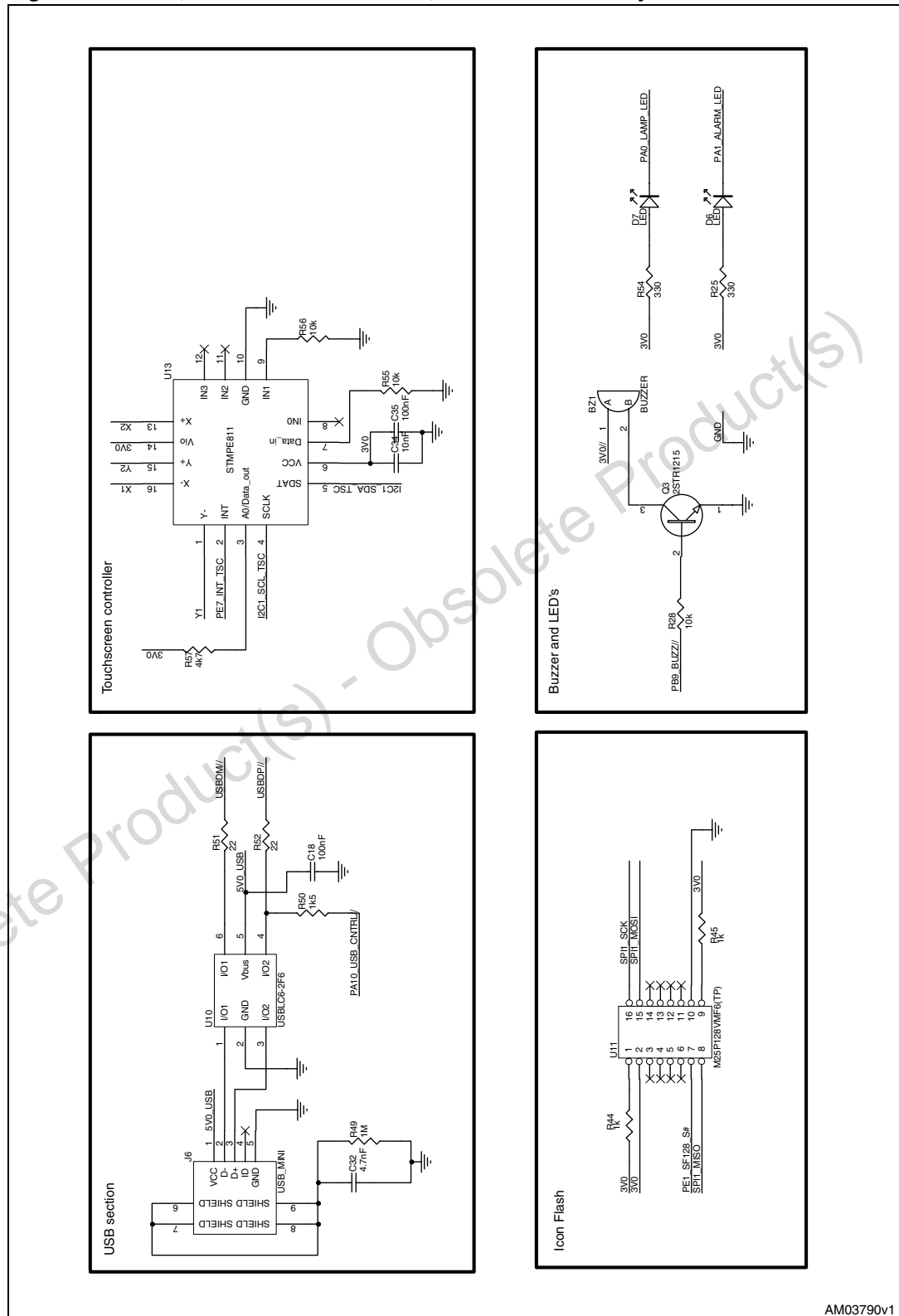

AM03790v1

## 2 Revision history

Table 1. Document revision history

Date	Revision	Changes
14-Apr-2009	1	Initial release.

Obsolete Product(s) - Obsolete Product(s)

**Please Read Carefully:**

Information in this document is provided solely in connection with ST products. STMicroelectronics NV and its subsidiaries ("ST") reserve the right to make changes, corrections, modifications or improvements, to this document, and the products and services described herein at any time, without notice.

All ST products are sold pursuant to ST's terms and conditions of sale.

Purchasers are solely responsible for the choice, selection and use of the ST products and services described herein, and ST assumes no liability whatsoever relating to the choice, selection or use of the ST products and services described herein.

No license, express or implied, by estoppel or otherwise, to any intellectual property rights is granted under this document. If any part of this document refers to any third party products or services it shall not be deemed a license grant by ST for the use of such third party products or services, or any intellectual property contained therein or considered as a warranty covering the use in any manner whatsoever of such third party products or services or any intellectual property contained therein.

**UNLESS OTHERWISE SET FORTH IN ST'S TERMS AND CONDITIONS OF SALE ST DISCLAIMS ANY EXPRESS OR IMPLIED WARRANTY WITH RESPECT TO THE USE AND/OR SALE OF ST PRODUCTS INCLUDING WITHOUT LIMITATION IMPLIED WARRANTIES OF MERCHANTABILITY, FITNESS FOR A PARTICULAR PURPOSE (AND THEIR EQUIVALENTS UNDER THE LAWS OF ANY JURISDICTION), OR INFRINGEMENT OF ANY PATENT, COPYRIGHT OR OTHER INTELLECTUAL PROPERTY RIGHT.**

**UNLESS EXPRESSLY APPROVED IN WRITING BY AN AUTHORIZED ST REPRESENTATIVE, ST PRODUCTS ARE NOT RECOMMENDED, AUTHORIZED OR WARRANTED FOR USE IN MILITARY, AIR CRAFT, SPACE, LIFE SAVING, OR LIFE SUSTAINING APPLICATIONS, NOR IN PRODUCTS OR SYSTEMS WHERE FAILURE OR MALFUNCTION MAY RESULT IN PERSONAL INJURY, DEATH, OR SEVERE PROPERTY OR ENVIRONMENTAL DAMAGE. ST PRODUCTS WHICH ARE NOT SPECIFIED AS "AUTOMOTIVE GRADE" MAY ONLY BE USED IN AUTOMOTIVE APPLICATIONS AT USER'S OWN RISK.**

Resale of ST products with provisions different from the statements and/or technical features set forth in this document shall immediately void any warranty granted by ST for the ST product or service described herein and shall not create or extend in any manner whatsoever, any liability of ST.

ST and the ST logo are trademarks or registered trademarks of ST in various countries.

Information in this document supersedes and replaces all information previously supplied.

The ST logo is a registered trademark of STMicroelectronics. All other names are the property of their respective owners.

© 2009 STMicroelectronics - All rights reserved

STMicroelectronics group of companies

Australia - Belgium - Brazil - Canada - China - Czech Republic - Finland - France - Germany - Hong Kong - India - Israel - Italy - Japan - Malaysia - Malta - Morocco - Philippines - Singapore - Spain - Sweden - Switzerland - United Kingdom - United States of America

[www.st.com](http://www.st.com)