

THIS DRAWING IS UNPUBLISHED. RELEASED FOR PUBLICATION  
 © COPYRIGHT - By - ALL RIGHTS RESERVED.

LOC		DIST		REVISIONS			
P	LTR	DESCRIPTION		DATE	DWN	APVD	
AF	50	A2	ECR-13-016672	25OCT13	PKS	RRP	

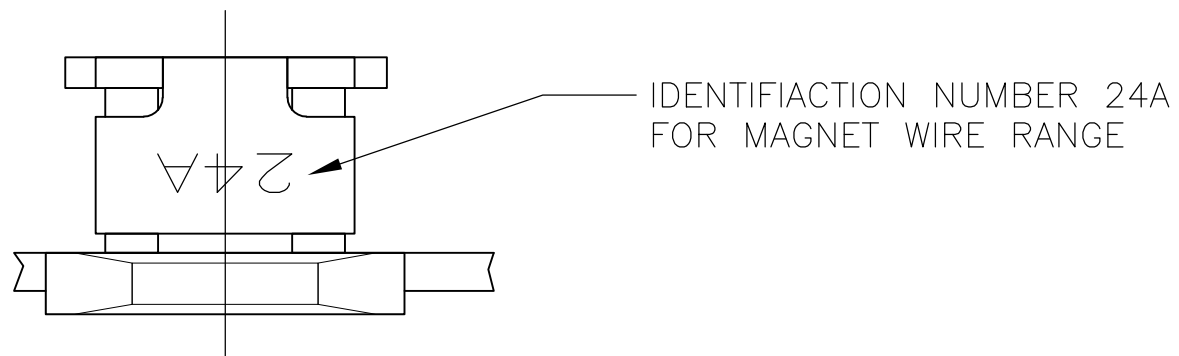

- 1 CONTINUOUS STRIP ON REELS WITH TERMINALS LOCATED ON  $.220 \pm .003$  CENTERS
- 2 SLOT TERMINATES A SINGLE MAGNET WIRE ONLY. ALUMINUM RANGE: 0.97-1.22mm [#18.5-#16.5] AWG.
- 3 AFTER INSERTION INTO PLASTIC HOLDER TAB PORTION MUST BE BENT OVER 45° TO 90° OR POTTED-IN TO PREVENT PULL-OUT WHEN MATING RECEPTACLE IS DISCONNECTED.

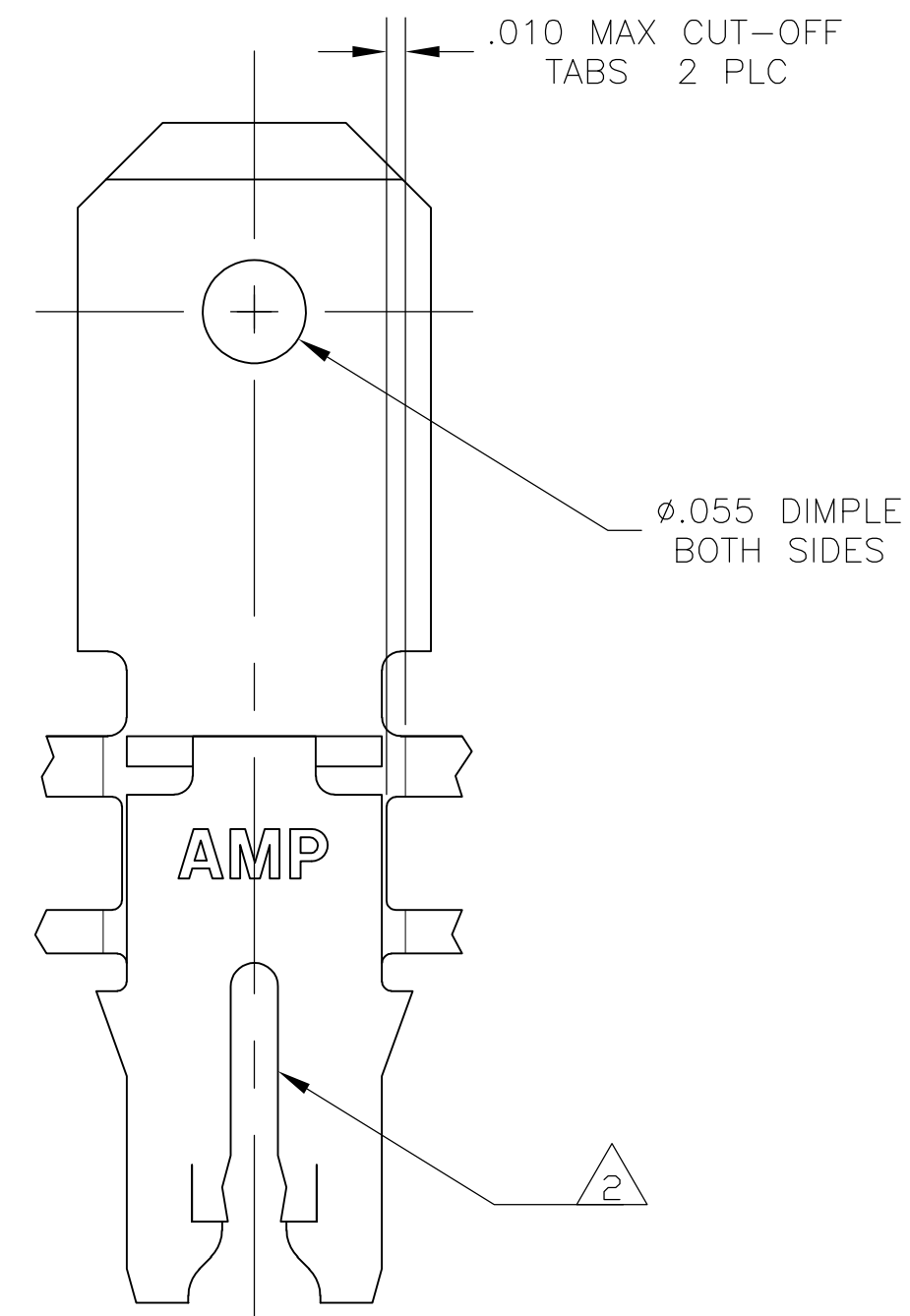
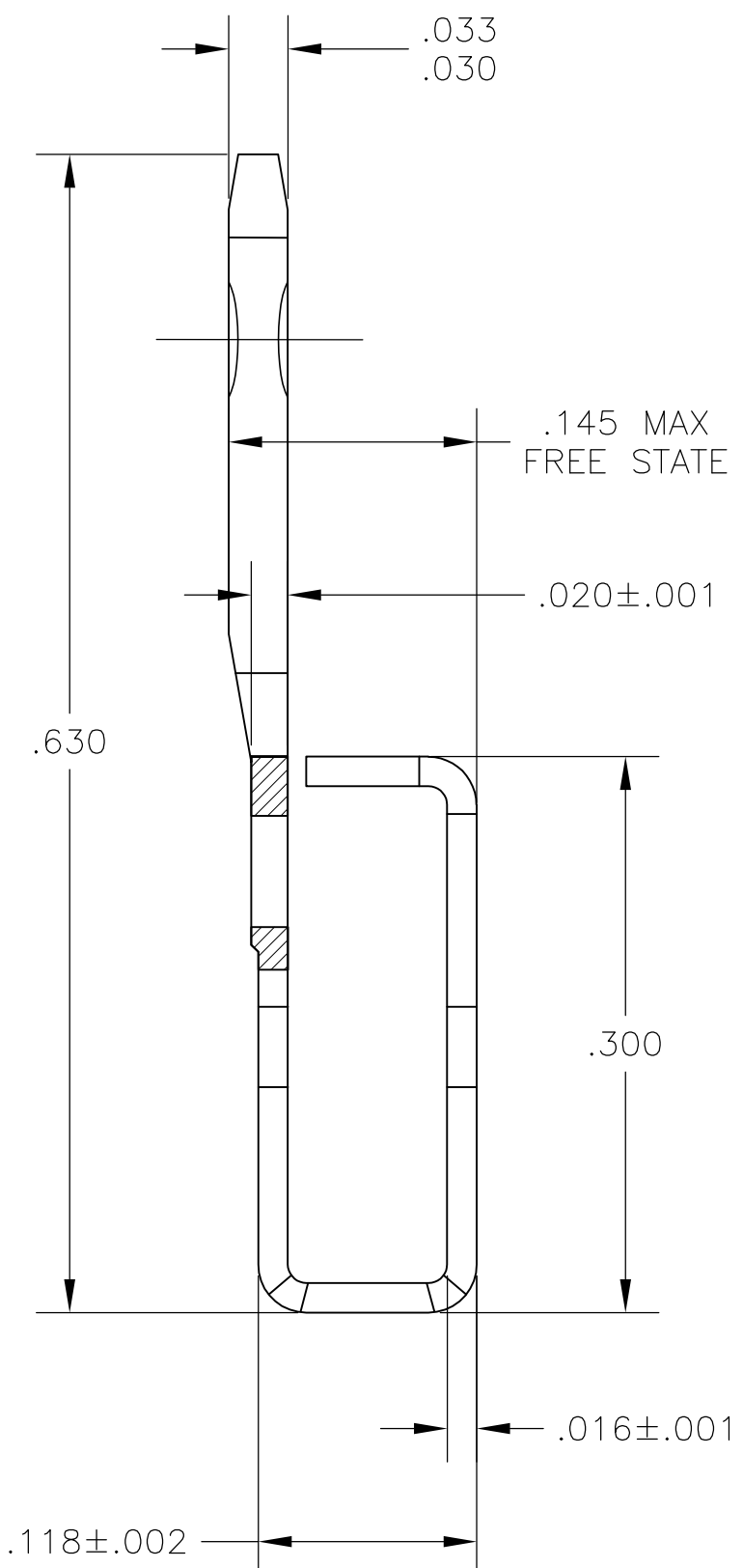
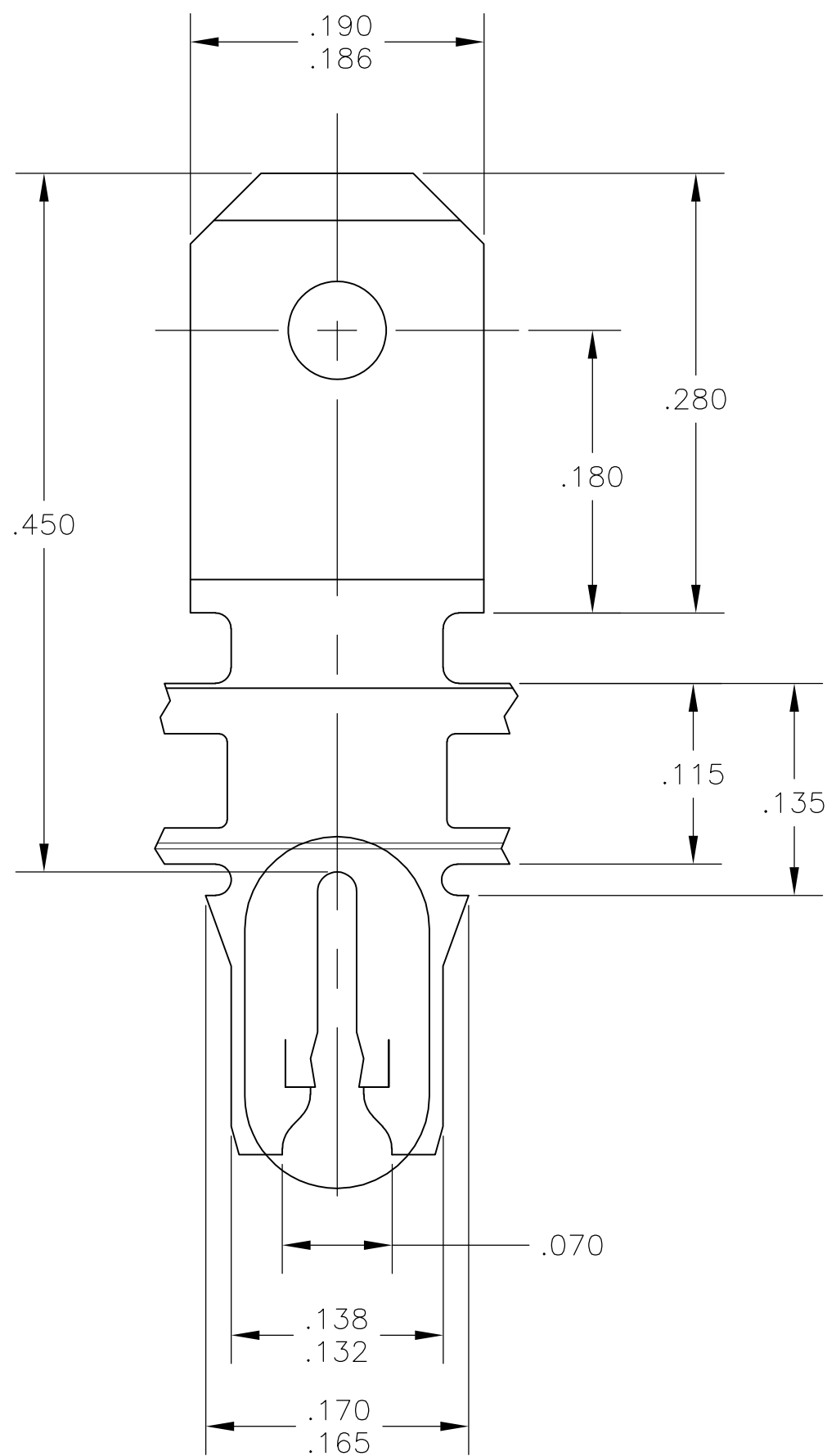

1742474-1  
PART NO

THIS DRAWING IS A CONTROLLED DOCUMENT.		DWN jr ruth 12SEP06	<b>TE</b> TE Connectivity	
DIMENSIONS: INCHES		CHK K RANDOLPH 12SEP06		
TOLERANCES UNLESS OTHERWISE SPECIFIED:		APVD K RANDOLPH 12SEP06	NAME TERMINAL, TAB, .187 FASTON, MAG-MATE	
0 PLC ± -		PRODUCT SPEC	SIZE A2	
1 PLC ± -		APPLICATION SPEC	CAGE CODE 00779	
2 PLC ± -		WEIGHT	DRAWING NO 1742474	
3 PLC ± .010		FINISH TIN PLATE	RESTRICTED TO	
4 PLC ± -		MATERIAL BRASS	SCALE 10:1	
ANGLES ± 5°		CUSTOMER DRAWING	SHEET 1 of 1	
			REV A2	