

42 V Input 4ch Window Voltage Detector

No. EA-521-230523

OVERVIEW

The R3500S is a 4ch window voltage detector with manual reset function suited for systems requiring functional safety. This device monitors over and under voltage from the multiple power supplies to SoCs, memories and sensors to continuously supervise the system operating at normal voltage.

KEY BENEFITS

- Power supply from battery enables the voltage detector to operate independently from the power source.
- High-accuracy detection of the over and under voltages from -1.25% to 0.75% and the hysteresis of Max. 0.75%.
- Management of multiple power supplies with a single chip to save space.

KEY SPECIFICATIONS

- Operating Voltage Range (Max. Rating):
3.0 V to 42.0 V (50.0 V)
- Operating Temperature Range: -40°C to 105°C
- Supply Current: Typ. 10 μ A
- Overvoltage Detection: 1.0 V to 5.9 V (0.01 V step)
- Undervoltage Detection: 0.9 V to 5.0 V (0.01 V step)
- Detection Release Hysteresis: Max. 0.75%
(-40°C to 105°C)
- Detection Voltage Accuracy:
 $\pm 0.5%$ ($T_a = 25^\circ\text{C}$)
 -1.25% to 0.75% (-40°C to 105°C)
- Detection Delay Time: Typ. 20 μ s
- Release Delay Time: Typ. 4 ms ($C_D = 0.01 \mu\text{F}$)
- Output Type: Nch. Open Drain

TYPICAL APPLICATION CIRCUIT

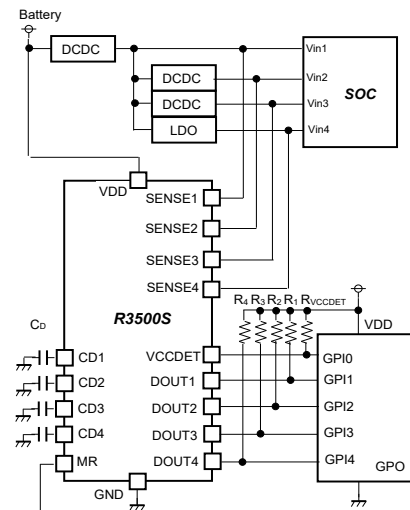

SELECTION GUIDE

Product Name	Package	Quantity per Reel
R3500SxxxA-E2-FE	HSOP-18	1,000 pcs

xxx: The combination of an overvoltage detection setting voltage (V_{OVSET}) and an undervoltage detection setting voltage (V_{UVSET}) applied to 4ch.

Refer to "Product-Specific Electrical Characteristic" for details

PACKAGE

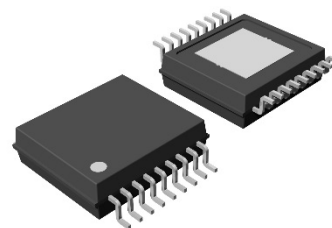

HSOP-18
5.2 x 6.2 x 1.45 (mm)

APPLICATIONS

- Power Supply Voltage Monitoring for Laptop PCs, Digital TVs, Cordless Phones and Private LAN Systems
- Power Supply Voltage Monitoring for Multi-cell Battery Using Devices

SELECTION GUIDE

The overvoltage detection setting voltage (V_{OVSET}) and the undervoltage detection setting voltage (V_{UVSET}) are user-selectable options.

Selection Guide

Product Name	Package	Quantity per Reel	Pb Free	Halogen Free
R3500SxxxA-E2-FE	HSOP-18	1,000 pcs	Yes	Yes

xxx: The combination of an overvoltage detection setting voltage (V_{OVSET}) and an undervoltage detection setting voltage (V_{UVSET}).

Refer to *Product-specific Electrical Characteristics* for more details.

BLOCK DIAGRAM

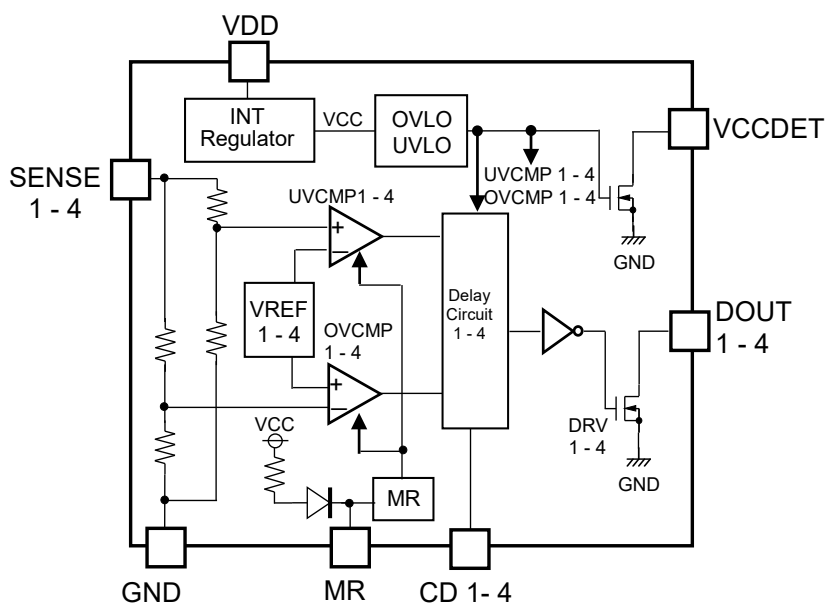

R3500S Block Diagram

PIN DESCRIPTIONS

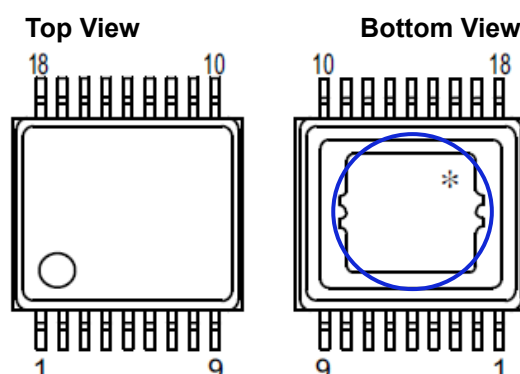

R3500S (HSOP-18) Pin Configuration

* The tab on the bottom of the package shown by blue circle is substrate potential (GND). It is recommended that this tab be connected to the ground plane pin on the board.

R3500S Pin Description

Pin No.	Symbol	Description
1	VDD	Supply Voltage Pin
2	NC	No Connection ⁽¹⁾
3	VCCDET ⁽²⁾	Over/Under Voltage Detection for Internal Supply Output Pin ("Low" at detection)
4	SENSE1	VD Voltage SENSE Pin 1
5	SENSE2	VD Voltage SENSE Pin 2
6	SENSE3	VD Voltage SENSE Pin 3
7	SENSE4	VD Voltage SENSE Pin 4
8	NC	No Connection
9	MR	Manual Reset Pin ("Low" at reset)
10	GND	GND Pin
11	CD4	VD Release Delay Time Set Pin 4 ("OPEN" when not connected)
12	CD3	VD Release Delay Time Set Pin 3 ("OPEN" when not connected)
13	CD2	VD Release Delay Time Set Pin 2 ("OPEN" when not connected)
14	CD1	VD Release Delay Time Set Pin 1 ("OPEN" when not connected)
15	DOUT4 ⁽³⁾	Over/Under Voltage Detection Output Pin 4 ("Low" at detection)
16	DOUT3 ⁽³⁾	Over/Under Voltage Detection Output Pin 3 ("Low" at detection)
17	DOUT2 ⁽³⁾	Over/Under Voltage Detection Output Pin 2 ("Low" at detection)
18	DOUT1 ⁽³⁾	Over/Under Voltage Detection Output Pin 1 ("Low" at detection)

⁽¹⁾ NC pin should be set to "OPEN".

⁽²⁾ VCCDET pin is required to pull up to a suitable voltage with an external resistor.

⁽³⁾ DOUT1 to 4 pins are required to pull up to a suitable voltage with an external resistor.

Internal Equivalent Circuit for Each Pin

DOUT1 to 4 Pin

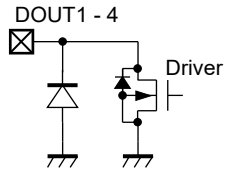

VCCDET Pin

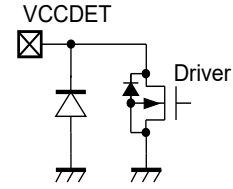

CD1 to 4 Pin

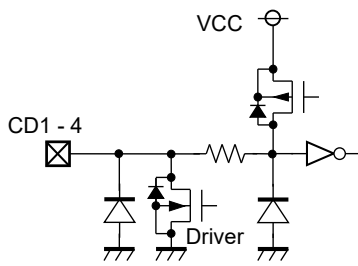

SENSE1 to 4 Pin

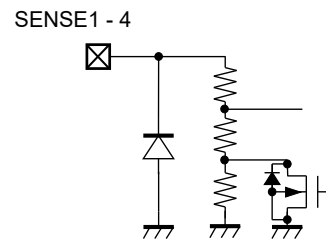

MR Pin

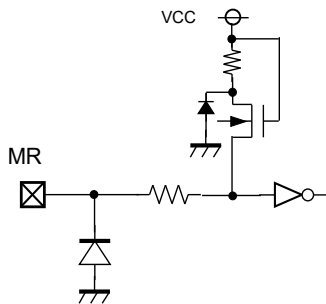

ABSOLUTE MAXIMUM RATINGS

Absolute Maximum Ratings

Symbol	Parameter	Rating	Unit
V_{DD}	Supply Voltage	-0.3 to 50.0	V
	Peak Voltage ⁽¹⁾	60	V
$V_{CD1\ to\ 4}$	CD1 to 4 Pin Output Voltage	-0.3 to 20.0	V
$V_{DOUT1\ to\ 4}$	DOUT1 to 4 Pin Output Voltage	-0.3 to 20.0	V
V_{VCCDET}	VCCDET Pin Output Voltage	-0.3 to 20.0	V
$V_{SENSE1\ to\ 4}$	SENSE1 to 4 Pin Input Voltage	-0.3 to 20.0	V
V_{MR}	MR Pin Voltage	-0.3 to 20.0	V
$I_{DOUT1\ to\ 4}$	DOUT1 to 4 Pin Output Current	30	mA
I_{VCCDET}	VCCDET Pin Output Current	15	mA
P_D	Power Dissipation	Refer to Appendix "POWER DISSIPATION"	
T_j	Junction Temperature Range	-40 to 125	°C
T_{stg}	Storage Temperature Range	-55 to 125	°C

ABSOLUTE MAXIMUM RATINGS

Electronic and mechanical stress momentarily exceeded absolute maximum ratings may cause permanent damage and may degrade the life time and safety for both device and system using the device in the field. The functional operation at or over these absolute maximum ratings are not assured.

RECOMMENDED OPERATING CONDITIONS

Recommended Operating Conditions

Symbol	Parameter	Rating	Unit
V_{DD}	Operating Voltage	3.0 to 42	V
$V_{SENSE1\ to\ 4}$	SENSE 1 to 4 Pin Input Voltage	0 to 6.0	V
V_{MR}	MR Pin Voltage	0 to 6.0	V
T_a	Operating Temperature Range	-40 to 105	°C

RECOMMENDED OPERATING CONDITIONS

All of electronic equipment should be designed that the mounted semiconductor devices operate within the recommended operating conditions. The semiconductor devices cannot operate normally over the recommended operating conditions, even if they are used over such ratings by momentary electronic noise or surge. And the semiconductor devices may receive serious damage when they continue to operate over the recommended operating conditions.

⁽¹⁾ Duration Time: within 200 ms

ELECTRICAL CHARACTERISTICS

$V_{DD} = 14\text{ V}$, $C_D = 0.01\ \mu\text{F}$, pulled-up to 5 V with 100 k Ω , unless otherwise specified.

The specifications surrounded by are guaranteed by design engineering at $-40^\circ\text{C} \leq T_a \leq 105^\circ\text{C}$.

R3500S (-FE) Electrical Characteristics

($T_a = 25^\circ\text{C}$)

Symbol	Parameter	Conditions	Min.	Typ.	Max.	Unit
$V_{OVDET1\text{ to }4}$	Overvoltage (OV) Detector Threshold	$T_a = 25^\circ\text{C}$	x0.995		x1.005	V
		$-40^\circ\text{C} \leq T_a \leq 105^\circ\text{C}$	x0.9875		x1.0075	V
$V_{UVDET1\text{ to }4}$	Undervoltage (UV) Detector Threshold	$T_a = 25^\circ\text{C}$	x0.995		x1.005	V
		$-40^\circ\text{C} \leq T_a \leq 105^\circ\text{C}$	x0.9875		x1.0075	V
$V_{OVHYS1\text{ to }4}$	Overvoltage (OV) Threshold Hysteresis		$\frac{V_{OVDET}}{\times 0.0025}$	$V_{OVDET} \times 0.005$	$\frac{V_{OVDET}}{\times 0.0075}$	V
$V_{UVHYS1\text{ to }4}$	Undervoltage (UV) Threshold Hysteresis		$\frac{V_{UVDET}}{\times 0.0025}$	$V_{UVDET} \times 0.005$	$\frac{V_{UVDET}}{\times 0.0075}$	V
I_{SS}	Supply Current	$V_{DD} = 42\text{ V}$, $V_{UVDET} < V_{SENSE} < V_{OVDET}$		10	25	μA
$R_{SENSE1\text{ to }4}$	SENSE1 to 4 Pin Resistance ⁽¹⁾		2.5		30	M Ω
V_{UVLO}	UVLO Detector Voltage			1.8	2.8	V
$V_{UVLOHYS}$	UVLO Threshold Hysteresis			0.1	0.2	V
$V_{DDLDO1\text{ to }4}$	Supply Voltage with Low-operating DOUT1 to 4 Pin Output Voltage ⁽²⁾				1.7	V
$I_{DOUT1\text{ to }4}$	DOUT1 to 4 Pin Driver Output Current	$V_{DD} = 3.0$, $V_{DS} = 0.1\text{ V}$	0.37	0.75	1.5	mA
$I_{LEAK1\text{ to }4}$	DOUT1 to 4 Pin Leak Current	$V_{DOUT1\text{ to }4} = 5.5\text{ V}$		0	1.0	μA
V_{MRH}	MR Input Voltage "High"		1.6			V
V_{MRL}	MR Input Voltage "Low"				0.5	V
$t_{DELAY1\text{ to }4}$	Release Delay Time	$C_D = 0.01\ \mu\text{F}$	2.5	4	8	ms
I_{VCCDET}	VCCDET Pin Driver Output Current	$V_{DD} = 3.0$, $V_{DS} = 0.1\text{ V}$	0.15	0.4	0.8	mA
$I_{LEAKVCCDET}$	VCCDET Pin Driver Leakage Current	$V_{DS} = 5.5\text{ V}$		0	0.3	μA

All test items listed in Electrical Characteristics are done under the pulse load condition ($T_J \approx T_a = 25^\circ\text{C}$).

⁽¹⁾ Typ. value is varied depending on the set value of detection voltage.

⁽²⁾ Minimum value of the power supply voltage when the detection output voltage becomes 0.1 V or lower.
(Pull-up resistance: 100 k Ω , Pull-up voltage: 5 V)

$V_{DD} = 14\text{ V}$, $C_D = 0.01\ \mu\text{F}$, pulled-up to 5 V with 100 k Ω , unless otherwise specified.

R3500S (-FE) Product-specific Electrical Characteristics

(Ta = 25°C)

Product name		V _{UVDET} (V)			V _{OVDET} (V)		
		Min.	Typ.	Max.	Min.	Typ.	Max.
R3500S001A	1ch	4.796	4.82	4.844	5.184	5.21	5.236
	2ch	3.165	3.18	3.195	3.413	3.43	3.447
	3ch	1.732	1.74	1.748	1.861	1.87	1.879
	4ch	1.055	1.06	1.065	1.135	1.14	1.145
R3500S002A	1ch	4.796	4.82	4.844	5.184	5.21	5.236
	2ch	3.165	3.18	3.195	3.413	3.43	3.447
	3ch	1.732	1.74	1.748	1.861	1.87	1.879
	4ch	1.155	1.16	1.165	1.244	1.25	1.256
R3500S003A	1ch	4.796	4.82	4.844	5.184	5.21	5.236
	2ch	3.165	3.18	3.195	3.413	3.43	3.447
	3ch	1.443	1.45	1.457	1.553	1.56	1.567
	4ch	0.966	0.97	0.974	1.035	1.04	1.045
R3500S004A	1ch	4.796	4.82	4.844	5.184	5.21	5.236
	2ch	3.165	3.18	3.195	3.413	3.43	3.447
	3ch	2.398	2.41	2.422	2.587	2.60	2.613
	4ch	1.055	1.06	1.065	1.135	1.14	1.145
R3500S005A	1ch	0.966	0.97	0.974	1.025	1.03	1.035
	2ch	1.702	1.71	1.718	1.881	1.89	1.899
	3ch	1.702	1.71	1.718	1.881	1.89	1.899
	4ch	3.125	3.14	3.155	3.453	3.47	3.487
R3500S006A	1ch	0.946	0.95	0.954	1.045	1.05	1.055
	2ch	1.155	1.16	1.165	1.244	1.25	1.256
	3ch	1.702	1.71	1.718	1.881	1.89	1.899
	4ch	3.125	3.14	3.155	3.453	3.47	3.487
R3500S007A	1ch	0.946	0.95	0.954	1.045	1.05	1.055
	2ch	1.274	1.28	1.286	1.413	1.42	1.427
	3ch	1.702	1.71	1.718	1.881	1.89	1.899
	4ch	3.125	3.14	3.155	3.453	3.47	3.487
R3500S008A	1ch	1.125	1.13	1.135	1.364	1.37	1.376
	2ch	2.985	3.00	3.015	3.582	3.60	3.618
	3ch	3.125	3.14	3.155	3.453	3.47	3.487
	4ch	3.125	3.14	3.155	3.453	3.47	3.487
R3500S009A	1ch	3.025	3.04	3.055	3.553	3.57	3.587
	2ch	3.025	3.04	3.055	3.553	3.57	3.587
	3ch	0.916	0.92	0.924	1.085	1.09	1.095
	4ch	0.916	0.92	0.924	1.085	1.09	1.095
R3500S010A	1ch	4.538	4.56	4.582	5.423	5.45	5.477
	2ch	2.995	3.01	3.025	3.582	3.60	3.618
	3ch	1.135	1.14	1.145	1.354	1.36	1.366
	4ch	1.165	1.17	1.175	1.403	1.41	1.417
R3500S011A	1ch	2.727	2.74	2.753	3.264	3.28	3.296
	2ch	1.632	1.64	1.648	1.961	1.97	1.979
	3ch	0.966	0.97	0.974	1.234	1.24	1.246
	4ch	2.995	3.01	3.025	3.582	3.60	3.618

$V_{DD} = 14\text{ V}$, $C_D = 0.01\ \mu\text{F}$, pulled-up to 5 V with 100 k Ω , unless otherwise specified.

The specifications surrounded by are guaranteed by design engineering at $-40^\circ\text{C} \leq T_a \leq 105^\circ\text{C}$.

R3500S (-FE) Product-specific Electrical Characteristics

(-40°C ≤ Ta ≤ 105°C)

Product name		V_{UVDET} (V)			V_{OVDET} (V)			V_{UVHYS} (V)			V_{OVHYS} (V)		
		Min.	Typ.	Max.	Min.	Typ.	Max.	Min.	Typ.	Max.	Min.	Typ.	Max.
R3500S001A	1ch	4.760	4.82	4.856	5.145	5.21	5.249	0.013	0.024	0.036	0.014	0.026	0.039
	2ch	3.141	3.18	3.203	3.388	3.43	3.455	0.008	0.016	0.023	0.009	0.017	0.025
	3ch	1.719	1.74	1.753	1.847	1.87	1.884	0.005	0.009	0.013	0.005	0.009	0.014
	4ch	1.047	1.06	1.067	1.126	1.14	1.148	0.003	0.005	0.007	0.003	0.006	0.008
R3500S002A	1ch	4.760	4.82	4.856	5.145	5.21	5.249	0.013	0.024	0.036	0.014	0.026	0.039
	2ch	3.141	3.18	3.203	3.388	3.43	3.455	0.008	0.016	0.023	0.009	0.017	0.025
	3ch	1.719	1.74	1.753	1.847	1.87	1.884	0.005	0.009	0.013	0.005	0.009	0.014
	4ch	1.146	1.16	1.168	1.235	1.25	1.259	0.003	0.006	0.008	0.004	0.006	0.009
R3500S003A	1ch	4.760	4.82	4.856	5.145	5.21	5.249	0.013	0.024	0.036	0.014	0.026	0.039
	2ch	3.141	3.18	3.203	3.388	3.43	3.455	0.008	0.016	0.023	0.009	0.017	0.025
	3ch	1.432	1.45	1.460	1.541	1.56	1.571	0.004	0.007	0.010	0.004	0.008	0.011
	4ch	0.958	0.97	0.977	1.027	1.04	1.047	0.003	0.005	0.007	0.003	0.005	0.007
R3500S004A	1ch	4.760	4.82	4.856	5.145	5.21	5.249	0.013	0.024	0.036	0.014	0.026	0.039
	2ch	3.141	3.18	3.203	3.388	3.43	3.455	0.008	0.016	0.023	0.009	0.017	0.025
	3ch	2.380	2.41	2.428	2.568	2.60	2.619	0.007	0.012	0.018	0.007	0.013	0.019
	4ch	1.047	1.06	1.067	1.126	1.14	1.148	0.003	0.005	0.007	0.003	0.006	0.008
R3500S005A	1ch	0.958	0.97	0.977	1.018	1.03	1.037	0.003	0.005	0.007	0.003	0.005	0.007
	2ch	1.689	1.71	1.722	1.867	1.89	1.904	0.005	0.009	0.012	0.005	0.009	0.014
	3ch	1.689	1.71	1.722	1.867	1.89	1.904	0.005	0.009	0.012	0.005	0.009	0.014
	4ch	3.101	3.14	3.163	3.427	3.47	3.496	0.008	0.016	0.023	0.009	0.017	0.026
R3500S006A	1ch	0.939	0.95	0.957	1.037	1.05	1.057	0.003	0.005	0.007	0.003	0.005	0.007
	2ch	1.146	1.16	1.168	1.235	1.25	1.259	0.003	0.006	0.008	0.004	0.006	0.009
	3ch	1.689	1.71	1.722	1.867	1.89	1.904	0.005	0.009	0.012	0.005	0.009	0.014
	4ch	3.101	3.14	3.163	3.427	3.47	3.496	0.008	0.016	0.023	0.009	0.017	0.026
R3500S007A	1ch	0.939	0.95	0.957	1.037	1.05	1.057	0.003	0.005	0.007	0.003	0.005	0.007
	2ch	1.264	1.28	1.289	1.403	1.42	1.430	0.004	0.006	0.009	0.004	0.007	0.010
	3ch	1.689	1.71	1.722	1.867	1.89	1.904	0.005	0.009	0.012	0.005	0.009	0.014
	4ch	3.101	3.14	3.163	3.427	3.47	3.496	0.008	0.016	0.023	0.009	0.017	0.026
R3500S008A	1ch	1.116	1.13	1.138	1.353	1.37	1.380	0.003	0.006	0.008	0.004	0.007	0.010
	2ch	2.963	3.00	3.022	3.555	3.60	3.627	0.008	0.015	0.022	0.009	0.018	0.027
	3ch	3.101	3.14	3.163	3.427	3.47	3.496	0.008	0.016	0.023	0.009	0.017	0.026
	4ch	3.101	3.14	3.163	3.427	3.47	3.496	0.008	0.016	0.023	0.009	0.017	0.026
R3500S009A	1ch	3.002	3.04	3.062	3.526	3.57	3.596	0.008	0.015	0.022	0.009	0.018	0.026
	2ch	3.002	3.04	3.062	3.526	3.57	3.596	0.008	0.015	0.022	0.009	0.018	0.026
	3ch	0.909	0.92	0.926	1.077	1.09	1.098	0.003	0.005	0.006	0.003	0.005	0.008
	4ch	0.909	0.92	0.926	1.077	1.09	1.098	0.003	0.005	0.006	0.003	0.005	0.008
R3500S010A	1ch	4.503	4.56	4.594	5.382	5.45	5.490	0.012	0.023	0.034	0.014	0.027	0.040
	2ch	2.973	3.01	3.032	3.555	3.60	3.627	0.008	0.015	0.022	0.009	0.018	0.027
	3ch	1.126	1.14	1.148	1.343	1.36	1.370	0.003	0.006	0.008	0.004	0.007	0.010
	4ch	1.156	1.17	1.178	1.393	1.41	1.420	0.003	0.006	0.008	0.004	0.007	0.010
R3500S011A	1ch	2.706	2.74	2.760	3.239	3.28	3.304	0.007	0.014	0.020	0.009	0.016	0.024
	2ch	1.620	1.64	1.652	1.946	1.97	1.984	0.005	0.008	0.012	0.005	0.010	0.014
	3ch	0.958	0.97	0.977	1.225	1.24	1.249	0.003	0.005	0.007	0.004	0.006	0.009
	4ch	2.973	3.01	3.032	3.555	3.60	3.627	0.008	0.015	0.022	0.009	0.018	0.027

TYPICAL APPLICATION CIRCUIT

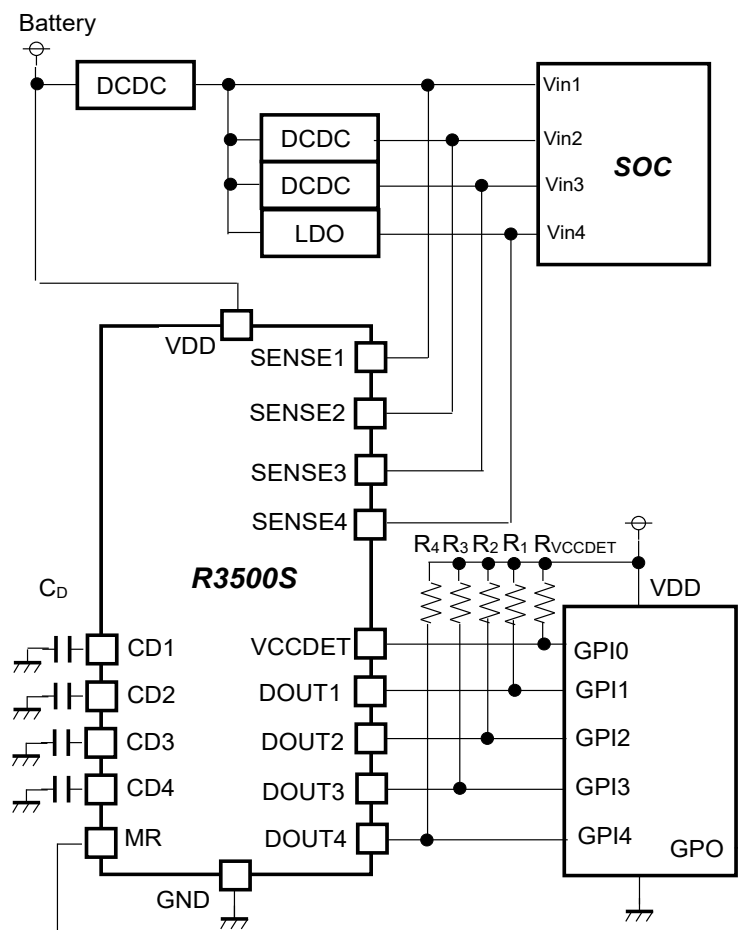

R3500S Typical Application

External Components

Symbol	Description
C_D	Capacitors should be selected corresponding to the set Release Delay Time. Refer to "Delay in Operation and Release Delay Time (t_{DELAY})" in THEORY OF OPERATION for details. When the Release Delay Time is unnecessary, layout the circuit without any capacitors.
R_n R_{VCCDET}	The on-resistance of the driver is max. 270 Ω calculated from the DOUTn (n=1 to 4) pin driver output current shown in "Electrical Characteristics". The maximum voltage at DOUTn="Low" is determined by the maximum on-resistance, pull-up voltage and R_n . The off-resistance of the driver is min. 5.5 M Ω calculated from the driver leakage current shown in "Electrical Characteristics". The minimum voltage at DOUTn="High" is determined by the minimum off-resistance, pull-up voltage and R_n . Set the VCCDET pin in the same way. "Electrical Characteristic" is evaluated in conditions that Pull-up voltage = 5 V and R_n = 100 k Ω . SENSEn and DOUTn pins should be set to open when they are not connected.

THEORY OF OPERATION

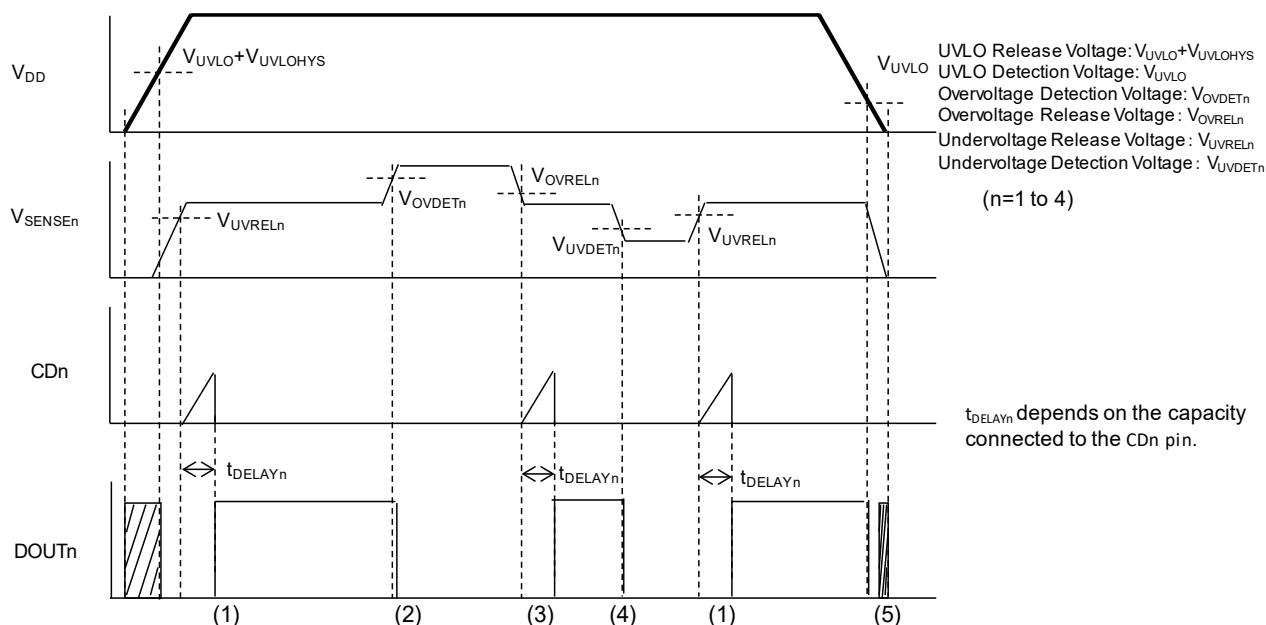

R3500S Timing Chart

- (1) When the SENSE_n pin voltage (V_{SENSEn}) exceeds the undervoltage release voltage (V_{UVRELn}), the DOUT_n pin outputs "High" after the release delay time (t_{DELAYn}).
- (2) When V_{SENSEn} exceeds the overvoltage detection voltage ($V_{OVDETrn}$), the DOUT_n pin outputs "Low" after the detection delay time (Typ.20 μ s) and this triggers the overvoltage detecting state.
- (3) When V_{SENSEn} drops below the overvoltage release voltage (V_{OVRELn}), the DOUT_n pin outputs "High" after the release delay time (t_{DELAYn}).
- (4) When V_{SENSEn} drops further below the undervoltage detection voltage ($V_{UVDETrn}$), the DOUT_n pin outputs "Low" after the detection delay time (Typ.20 μ s) and this triggers the undervoltage detecting state.
- (5) When the VDD pin voltage (V_{DD}) drops below the UVLO detection voltage (V_{UVLO}), the DOUT_n pin outputs "Low". Note that DOUT_n cannot maintain "Low" when the VDD pin voltage drops further and becomes lower than $V_{DDLDOUTn}$.

Delay Operation and Release Delay Time (t_{DELAY})

At Undervoltage Detection

A higher voltage than the undervoltage release voltage (V_{UVRELn}) supplied to the SENSEn pin triggers charging of the external capacitor then the CDn pin voltage (V_{CDn}) increases. The DOUTn pin voltage (V_{DOUTn}) maintains “Low” until V_{CDn} reaches the CDn pin threshold voltage (V_{TCDn}). When V_{CDn} exceeds V_{TCDn} , V_{DOUTn} transitions from “Low” to “High”. The release delay time (t_{DELAYn}) is the period until V_{DOUTn} transitions to “High” after the SENSEn pin voltage (V_{SENSEn}) exceeds V_{UVRELn} . The output voltage transitions from “Low” to “High” and it leads to discharging of the external capacitor. Without CD capacitors, the release delay time (Typ. 20 μ s) becomes short depending on the circuit delay and CDn pin stray capacitance. When the lower voltage than V_{UVDETn} is supplied to the SENSEn pin, the detection delay time (t_{PHLn}) for which V_{DOUTn} transitions from “High” to “Low” is independent from the external capacitor and will be constant.

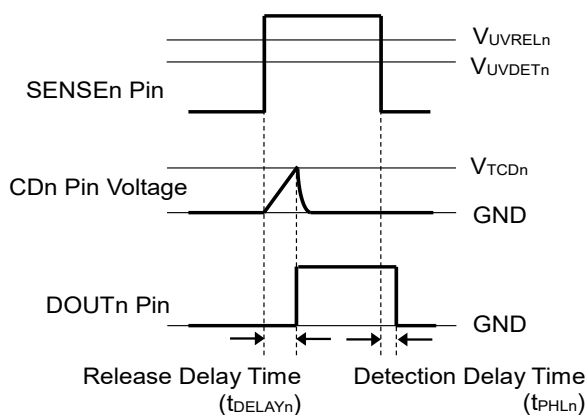

Undervoltage Release Delay Timing Diagram

Calculation of Release Delay Time (t_{DELAY})

The typical value of the release delay time (t_{DELAYn}) with the capacitance of the external capacitor (C_D) is calculated in the following equation:

$$t_{DELAYn} (s) = 0.73 \times C_D (F) / (1.8 \times 10^{-6})$$

t_{DELAYn} is the period until the DOUTn pin voltage (V_{DOUTn}) reaches 2.5 V after the pulse voltage of $(V_{UVDETn} + V_{OVDETn}) / 2$ V increased from $(V_{UVDETn} \times 0.97)$ V is supplied to the SENSEn pin when V_{DOUTn} is pulled up to 5 V with 100 k Ω .

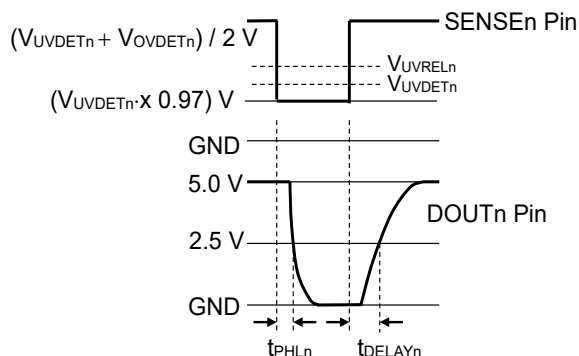

At Overvoltage Detection

A lower voltage than the overvoltage release voltage (V_{OVRELn}) supplied to the SENSEn pin triggers charging of the external capacitor then the CDn pin voltage (V_{CDn}) increases. The DOUTn pin voltage (V_{DOUTn}) maintains “Low” until V_{CDn} reaches the CDn pin threshold voltage (V_{TCDn}). When V_{CDn} exceeds V_{TCDn} , V_{DOUTn} transitions from “Low” to “High”. The release delay time (t_{DELAYn}) is the period until V_{DOUTn} transitions to “High” after the SENSEn pin voltage (V_{SENSEn}) exceeds V_{OVRELn} . The output voltage transitions from “Low” to “High” and it leads to discharging of the external capacitor. Without CD capacitors, the release delay time (Typ. 20 μ s) becomes short depending on the circuit delay and CDn pin stray capacitance. When the higher voltage than V_{OVDETn} is supplied to the SENSEn pin, the detection delay time (t_{PHLn}) for which V_{DOUTn} transitions from “High” to “Low” is independent from the external capacitor and will be constant.

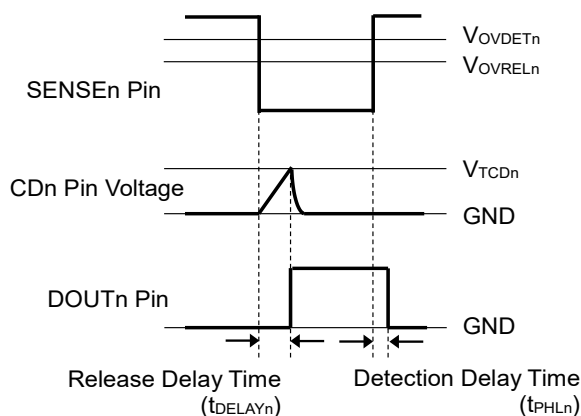

Overvoltage Release Delay Timing Diagram

Calculation of Release Delay Time (t_{DELAY})

The typical value of the release delay time (t_{DELAYn}) with the capacitance of the external capacitor (C_D) is calculated in the following equation:

$$t_{DELAYn} \text{ (s)} = 0.73 \times C_D \text{ (F)} / (1.8 \times 10^{-6})$$

t_{DELAYn} is the period until the DOUTn pin voltage (V_{DOUTn}) reaches 2.5 V after the pulse voltage of $(V_{UVDETn} + V_{OVDETn}) / 2$ V decreased from $(V_{OVDETn} \times 1.03)$ V is supplied to the SENSEn pin when V_{DOUTn} is pulled up to 5 V with 100 k Ω .

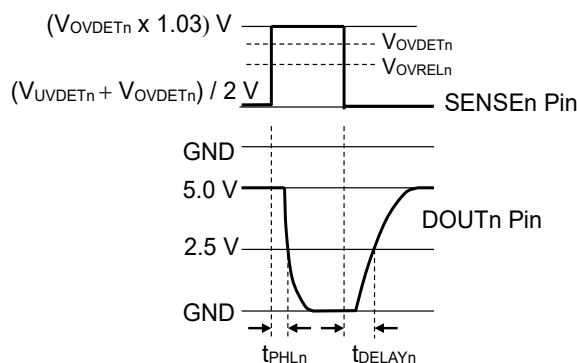

Manual Reset Function with MR Pin

The manual reset function is to set DOUTn to "Low" by inputting "Low" to the MR pin even when V_{SENSEn} is within a range of the release voltage. In other cases, set the MR pin voltage to "High" or open. In a system without using the manual reset function, set the MR pin voltage to "High" or open.

(Pull-up resistance: Typ. 100 k Ω)

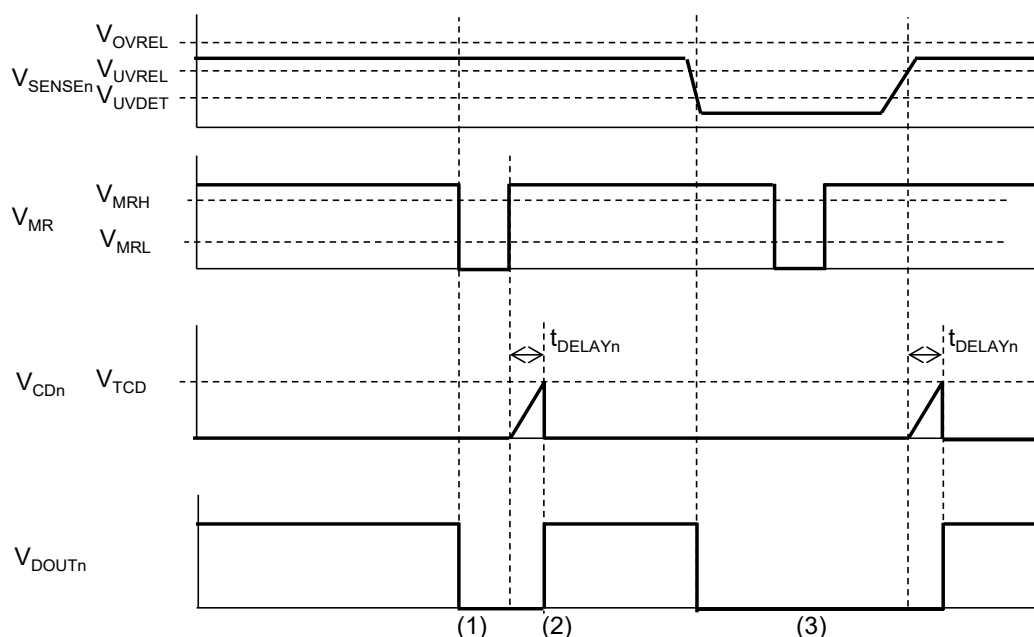

Manual Reset Timing Chart

- (1) When inputting "Low" to the MR pin, DOUTn is fixed to "Low" after the manual reset detection delay time (Typ. 20 μ s) even if the SENSEn pin voltage (V_{SENSEn}) is within a range of the release voltage. The "Low" signal should be 50 μ s or more.
- (2) When the MR pin transitions from "Low" to "High", DOUTn becomes "High" after the release delay time (t_{DELAYn}). At this time, the MR pin should maintain "High" for the release delay time or longer. Even if the external capacitor (CDn capacitance) is not connected, it should maintain "High" for 50 μ s or more.
- (3) When V_{SENSEn} is lower than V_{UVDETn} or higher than V_{OVDETn} , and DOUTn is "Low", DOUTn does not transition even when the MR pin is set to "Low".

APPLICATION INFORMATION

Internal Supply Voltage Monitoring with VCCDET

The R3500 has a voltage regulator (INT regulator) inside the IC. Major functions of the IC are operated by VCC (Typ. 3.3V) generated by INT regulator from input voltage, VDD. The overvoltage detection circuit, OVLO and the undervoltage detection circuit, UVLO monitor the VCC being within the normal voltage range. When VCC is out of the normal range, NMOS driver connected to VCCDET pin turns on. By pulling up VCCDET pin, when OVLO or UVLO detects an abnormal VCC voltage, the output of VCCDET pin becomes "L". By monitoring VCC, UVLO also monitors undervoltage of VDD indirectly.

Even if pulled up VCCDET pin becomes "L", the R3500 doesn't lose the voltage detector function immediately. VCCDET pin should be set to open when it is unused.

R3500 Fault Detection Utilizing the Manual Reset Function

When a DOUTn pin output is "H", it's very important to know whether it's a result of normal voltage detector function or malfunction.

Utilizing the R3500 manual reset function, one part of IC faults can be detected. By the manual reset function, when "L" signal is input to MR pin, DOUTn pin output is fixed to "L" forcibly. If DOUTn pin doesn't become "L" even though SENSE pin voltage is within the released voltage range and "L" is input to MR pin, this can be determined as an IC fault.

When DOUTn is fixed to "H" due to an IC fault, DOUTn pin doesn't become "L" even "L" signal is input to MR pin. The faults can be detected with the manual reset function of the R3500 by checking DOUTn pin condition as above, are a wire open fault of DOUTn pin or an open fault of the output driver.

When detect IC faults with the manual reset function, follow the "Manual Reset Function with MR Pin" noted previously.

The system which usually receives output from DOUTn pin should not receive output from DOUTn pin during a fault detection test.

The concept of “H” level of MR pin

The R3500 has a voltage regulator (INT regulator) inside the IC. Major functions of the IC are operated by VCC (Typ. 3.3V) generated by INT regulator from input voltage, VDD.

MR pin is pulled up to VCC voltage via 100kΩ as it can be set to open when MR pin is unused.

When the manual reset function is in use, when input “L” signal to MR pin, then DOUTn pin becomes “L”. But when the manual reset function is in no use, if “H” voltage is input to MR pin, the current which is determined by the following equation flows continuously. This makes the supply current increase.

$$(VCC - \text{MR "H" voltage}) / 100k\Omega \quad (VCC > \text{MR "H" voltage})$$

Unless there's a specific reason to avoid an OPEN pin condition, it's recommended to be left OPEN when MR pin is not used.

As the circuit configuration prevents a reverse current from MR pin to VCC, even when being used in condition of MR “H” voltage > VCC, supply current doesn't increase and VCC voltage doesn't vary.

TYPICAL CHARACTERISTICS

Note: Typical Characteristics are intended to be used as reference data; they are not guaranteed.

1) Supply Current vs. Input Voltage

$V_{UVSET} = 4.82V / V_{OVSET} = 5.21V$, $V_{UVSET} = 3.18V / V_{OVSET} = 3.43V$, $V_{UVSET} = 1.74V / V_{OVSET} = 1.87V$,
 $V_{UVSET} = 0.97V / V_{OVSET} = 1.04V$

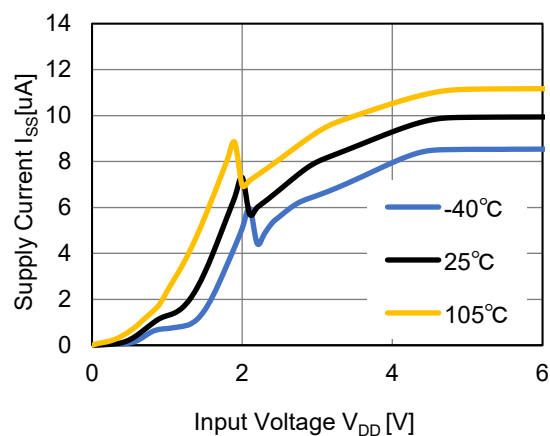
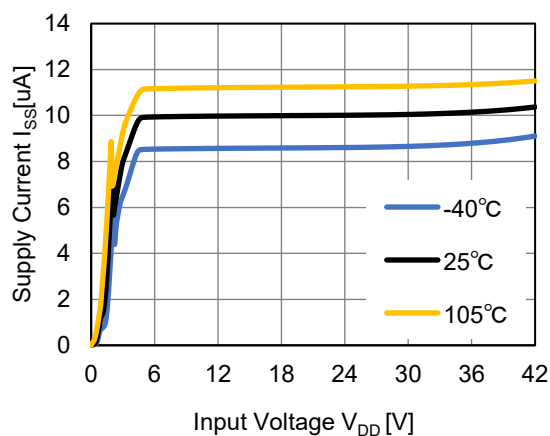

2) SENSE Current vs. Input Voltage

$V_{UVSET} = 3.18V / V_{OVSET} = 3.43V$

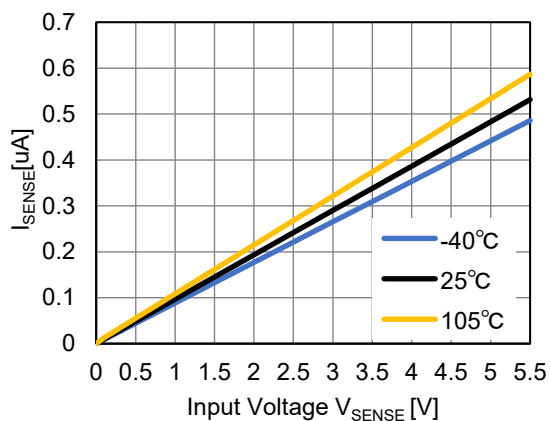

3) UV / OV Detection • Release Voltage vs. Temperature

$V_{DD} = 14V$, $V_{OVSET} = 5.21V$ / $V_{UVSET} = 4.82V$

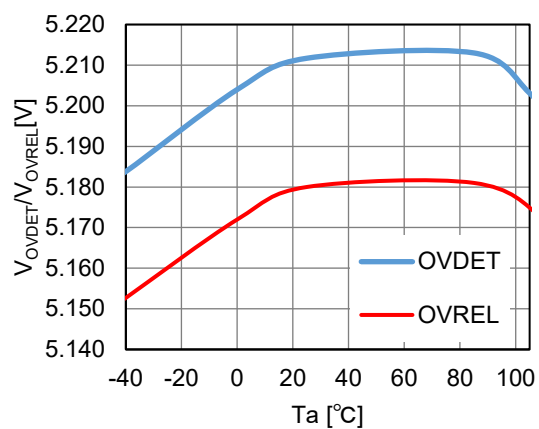
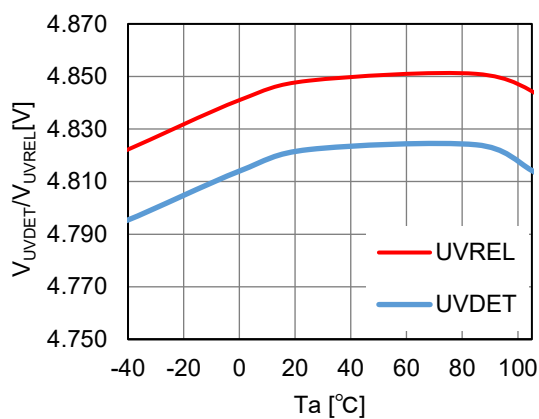

$V_{DD} = 14V$, $V_{OVSET} = 3.43V$ / $V_{UVSET} = 3.18V$

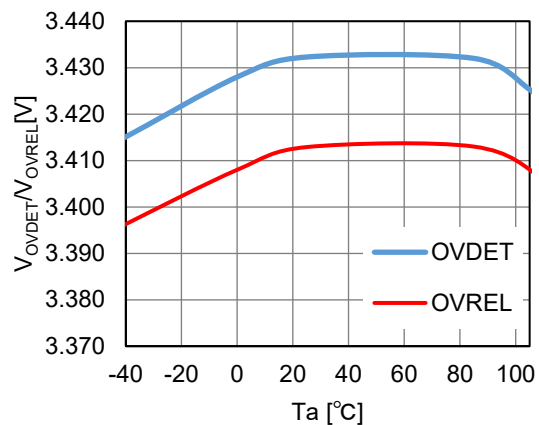
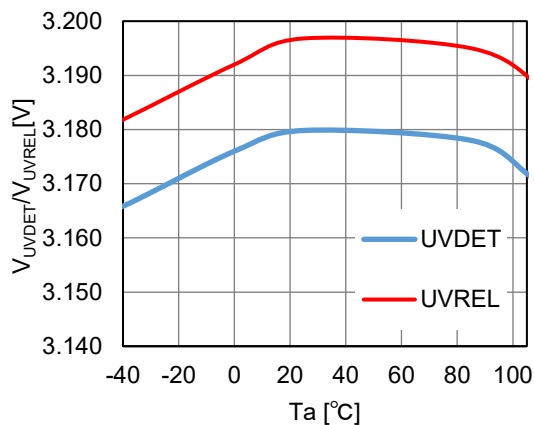

$V_{DD} = 14V$, $V_{OVSET} = 1.87V$ / $V_{UVSET} = 1.74V$

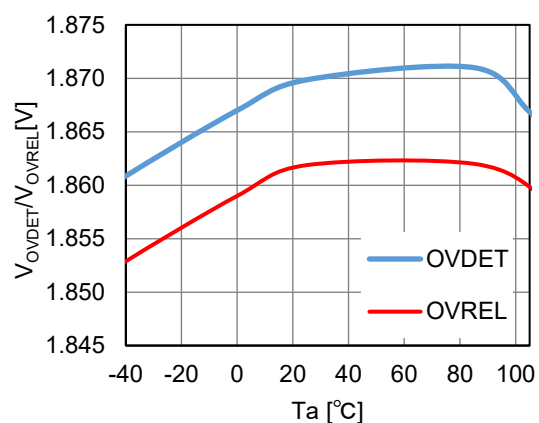
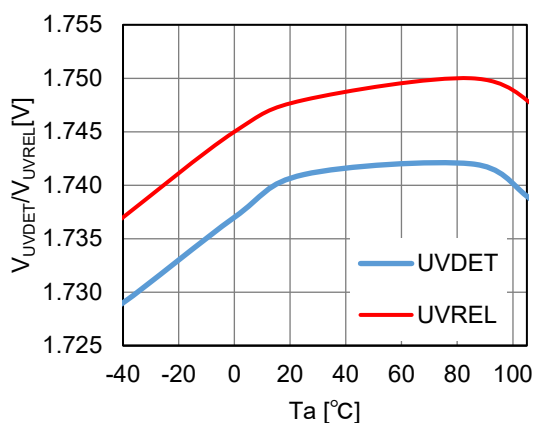

$V_{DD} = 14V, V_{OVSET} = 1.04V / V_{UVSET} = 0.97V$

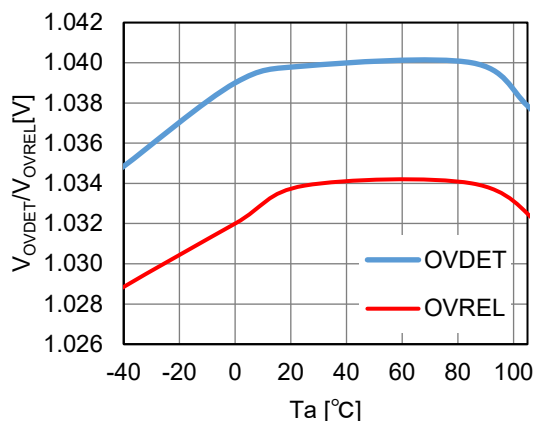
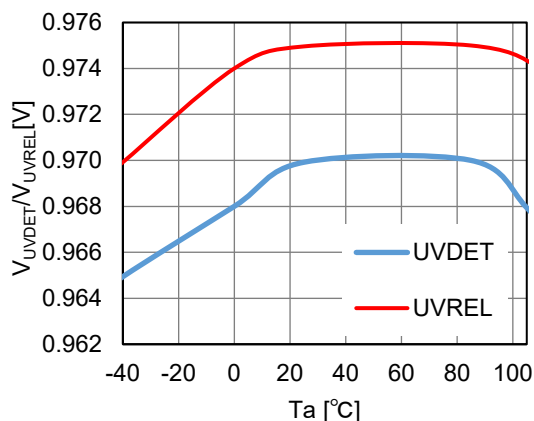

4) UV / OV Detection - Release Voltage vs. Input Voltage

$V_{DD} = 14V, V_{OVSET} = 5.21V / V_{UVSET} = 4.82V$

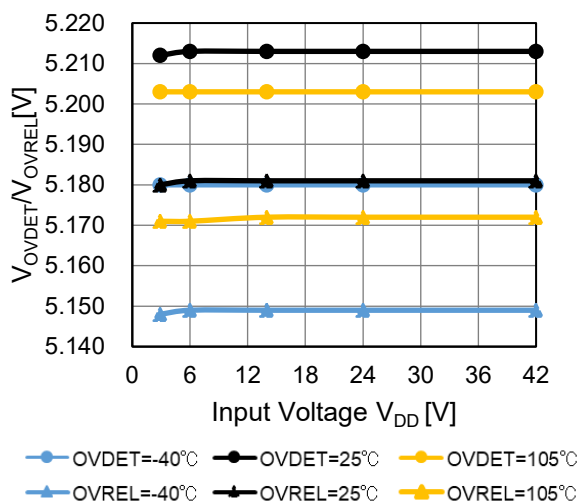
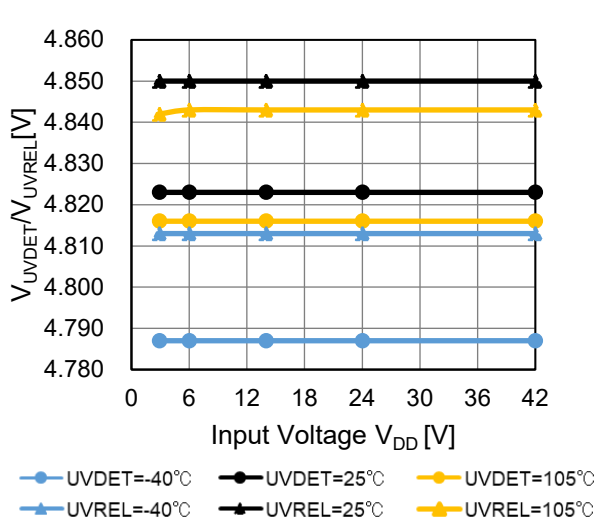

$V_{DD} = 14V, V_{OVSET} = 3.43V / V_{UVSET} = 3.18V$

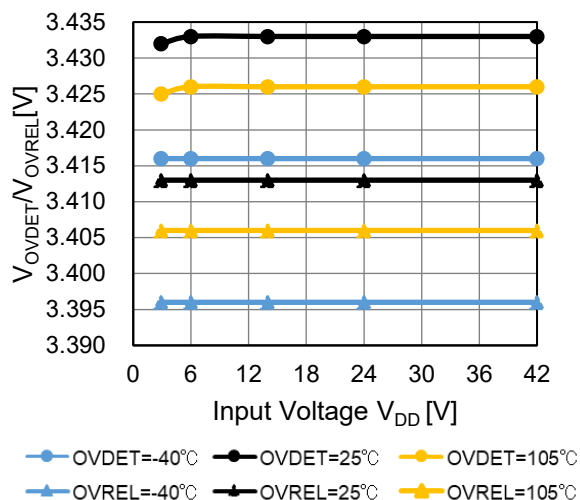
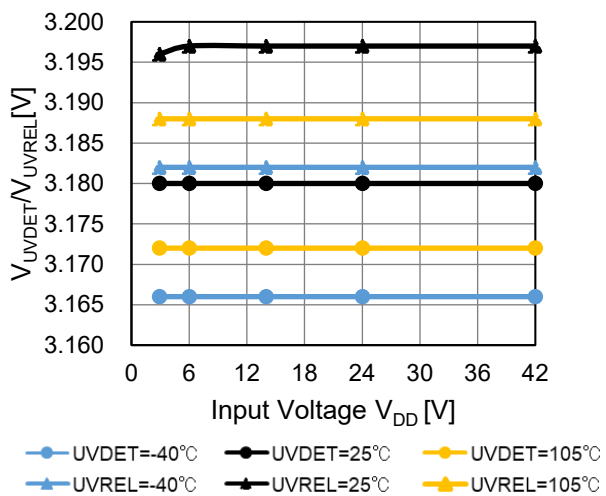

$V_{DD} = 14V, V_{OVSET} = 1.87V / V_{UVSET} = 1.74V$

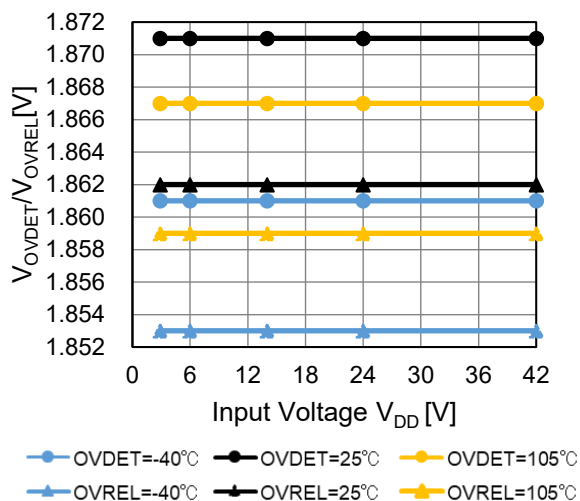
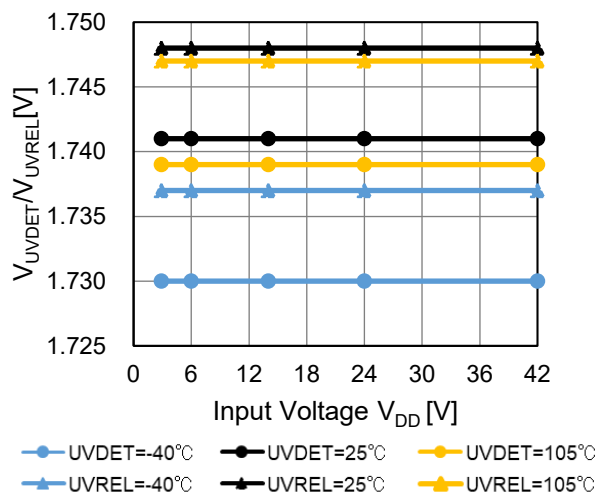

$V_{DD} = 14V, V_{OVSET} = 1.04V / V_{UVSET} = 0.97V$

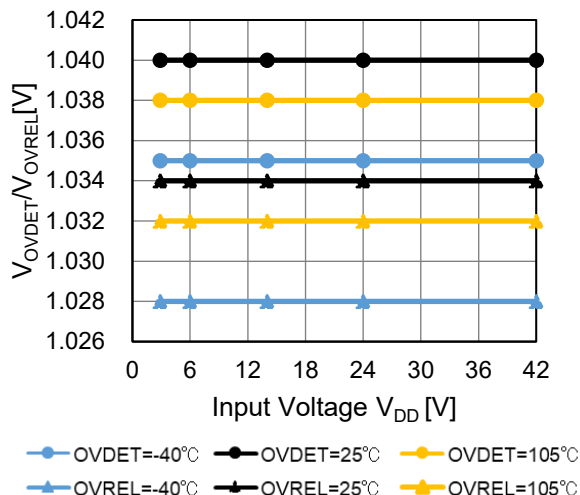
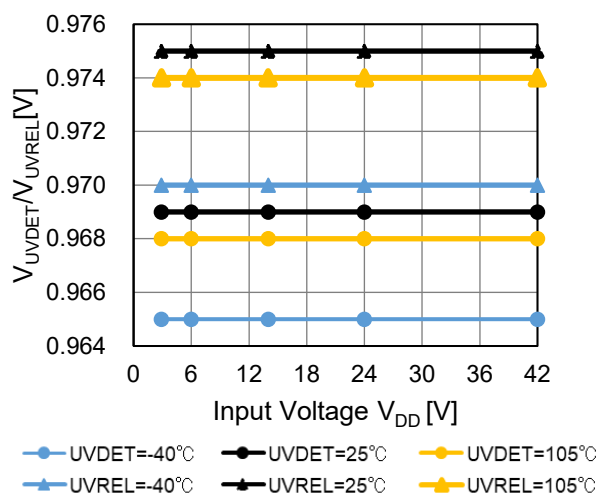

5) DOUT Pin Voltage vs. Input Voltage

$V_{SENSE} = (V_{OVSET} + V_{UVSET})/2$, Pull-up Voltage = 5V

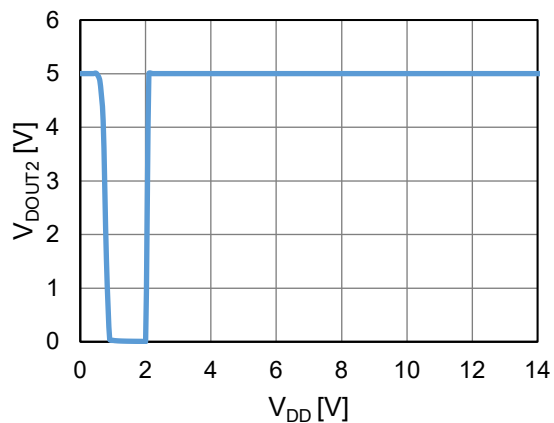

6) DOUT Pin Voltage vs. SENSE Pin Voltage

$V_{UVSET} = 4.82V / V_{OVSET} = 5.21V,$
 $V_{UVSET} = 0.97V / V_{OVSET} = 1.04V, \text{ Pull-up Voltage} = 5V$

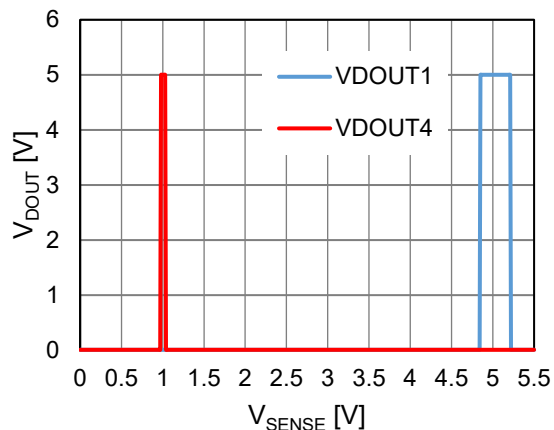

7) Driver Output Current vs. Input Voltage

$V_{SENSE} = 0V, V_{DOUT2} = 0.1V$

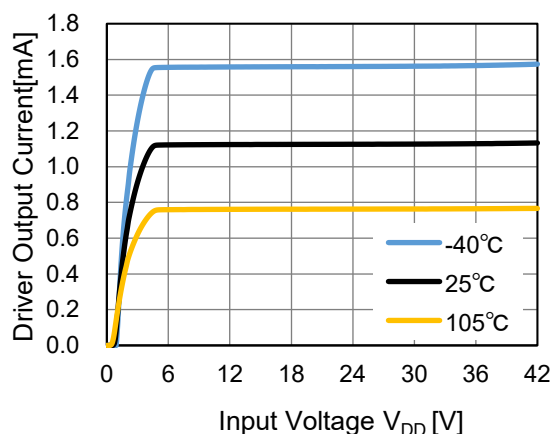

8) Driver Output Current vs. V_DS

$V_{SENSE} = 0V, V_{DOUT1/4} = 0V \rightarrow 14V$

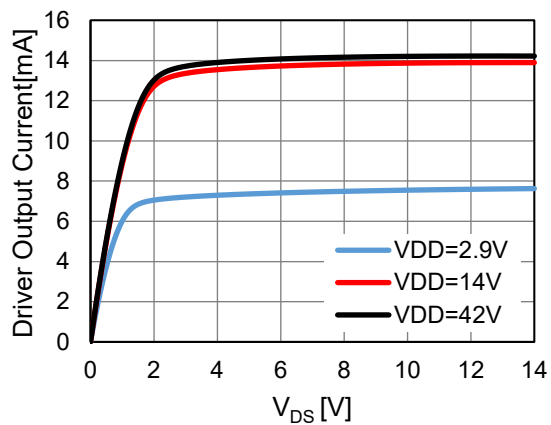
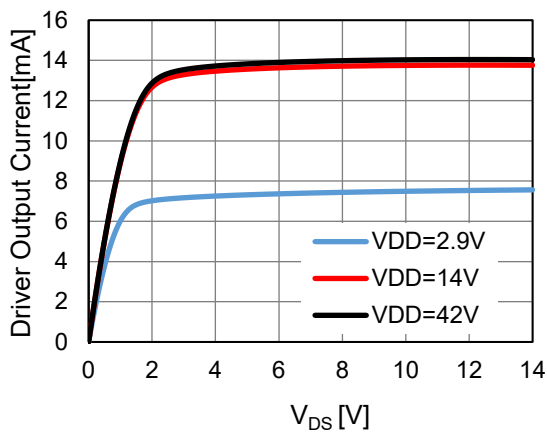

9) Release Delay Time vs. Temperature

$V_{SENSE} = 0V \rightarrow (V_{UVSET} + V_{OVSET})/2$ (UV)
 $V_{SENSE} = 5.5V \rightarrow (V_{UVSET} + V_{OVSET})/2$ (OV), $C_D = 10nF$

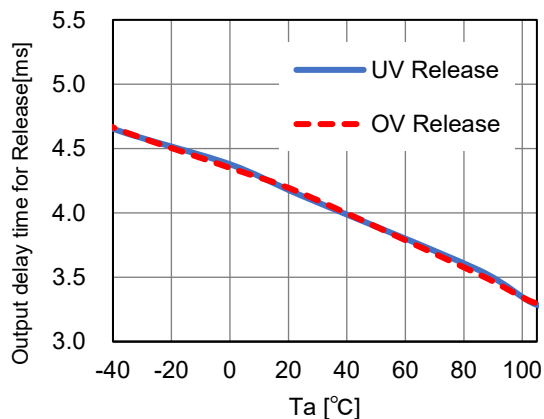

10) Release Delay Time vs. Input Voltage

$C_D = 10nF$

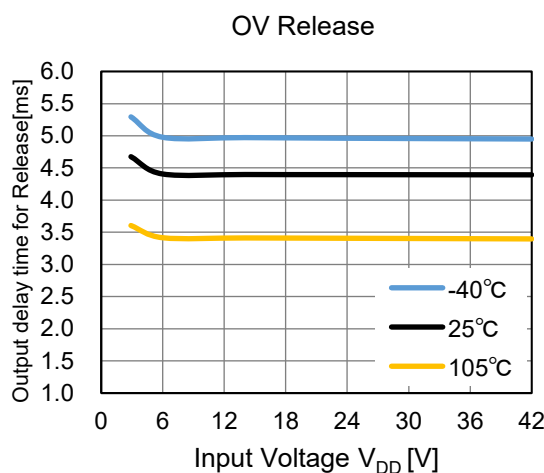
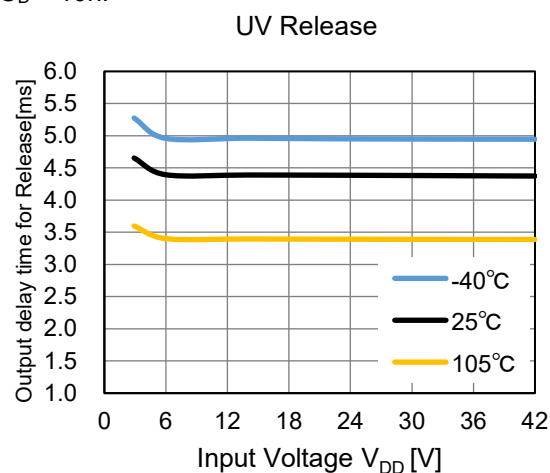

11) Release Delay Time vs. External Capacitor for CD Pin

$V_{DD} = 14V$

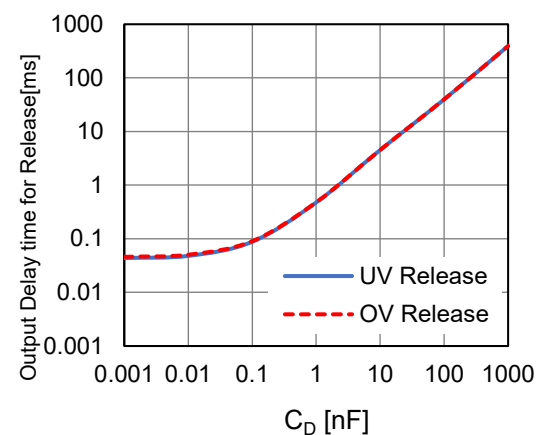

12) Detection Delay Time vs. Temperature

$V_{DD} = 14V,$

$V_{SENSE} = (V_{UVSET} + V_{OVSET})/2 \rightarrow 0V$ (UV),

$V_{SENSE} = (V_{UVSET} + V_{OVSET})/2 \rightarrow 5.5V$ (OV)

$V_{SENSE} = (V_{UVSET} + V_{OVSET})/2 \rightarrow V_{UVSET} \times 0.97V$ (UV),

$V_{SENSE} = (V_{UVSET} + V_{OVSET})/2 \rightarrow V_{OVSET} \times 1.03V$ (OV)

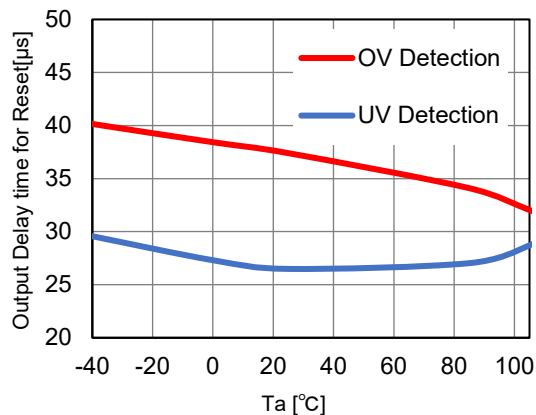
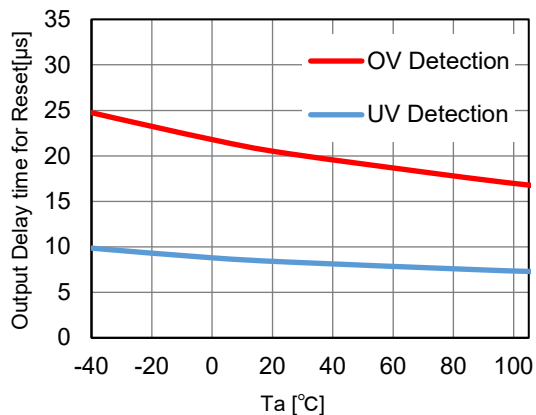

13) SENSE Pulse Width vs. Over Drive Voltage

$V_{DD} = 14V, V_{SENSE} = (V_{UVSET} + V_{OVSET})/2 \rightarrow (V_{UVSET} - \text{Over Drive Voltage})$ (UV),

$V_{SENSE} = (V_{UVSET} + V_{OVSET})/2 \rightarrow (V_{OVSET} + \text{Over Drive Voltage})$ (OV)

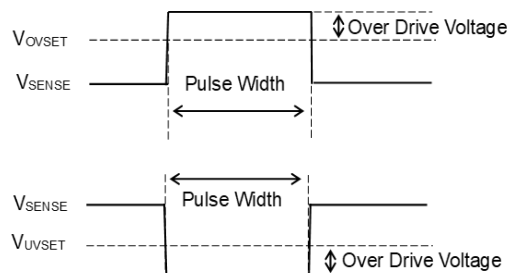
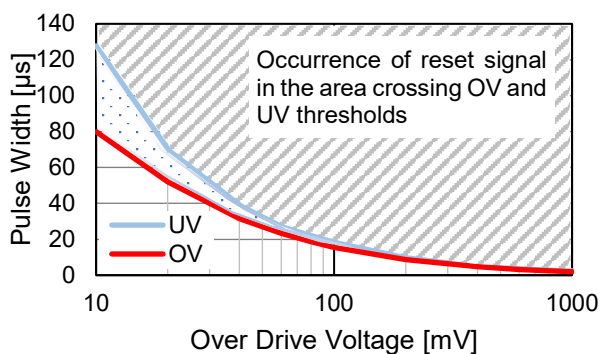

The power dissipation of the package is dependent on PCB material, layout, and environmental conditions. The following measurement conditions are based on JEDEC STD. 51-7.

Measurement Conditions

Item	Measurement Conditions
Environment	Mounting on Board (Wind Velocity = 0 m/s)
Board Material	Glass Cloth Epoxy Plastic (Four-Layer Board)
Board Dimensions	76.2 mm × 114.3 mm × 0.8 mm
Copper Ratio	Outer Layer (First Layer): Less than 95% of 50 mm Square Inner Layers (Second and Third Layers): Approx. 100% of 50 mm Square Outer Layer (Fourth Layer): Approx. 100% of 50 mm Square
Through-holes	φ 0.3 mm × 21 pcs

Measurement Result

(Ta = 25°C, Tjmax = 125°C)

Item	Measurement Result
Power Dissipation	3100 mW
Thermal Resistance (θ_{ja})	$\theta_{ja} = 32^{\circ}\text{C/W}$
Thermal Characterization Parameter (ψ_{jt})	$\psi_{jt} = 8^{\circ}\text{C/W}$

θ_{ja} : Junction-to-Ambient Thermal Resistance

ψ_{jt} : Junction-to-Top Thermal Characterization Parameter

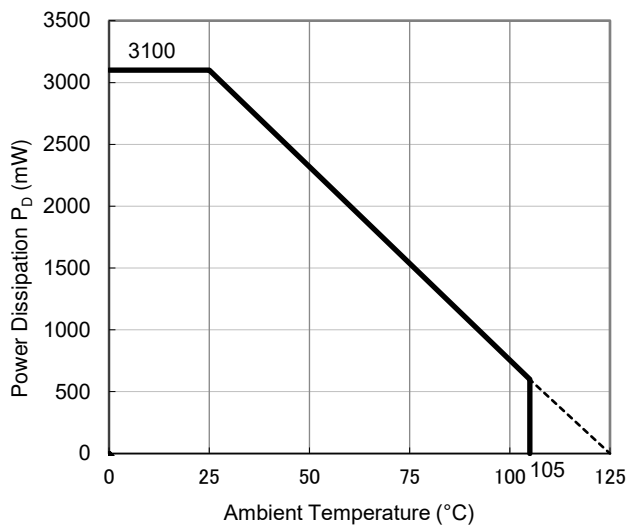

Power Dissipation vs. Ambient Temperature

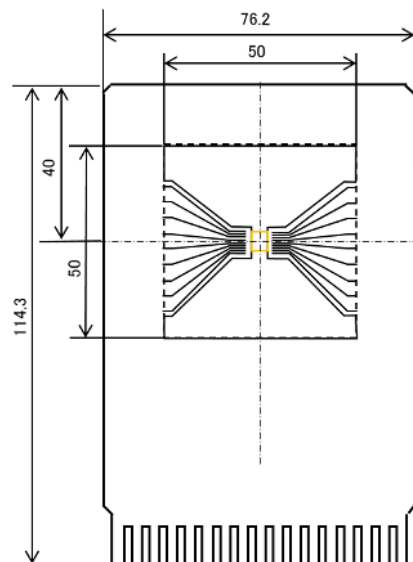

Measurement Board Pattern

PACKAGE DIMENSIONS

HSOP-18

DM-HSOP-18-JE-B

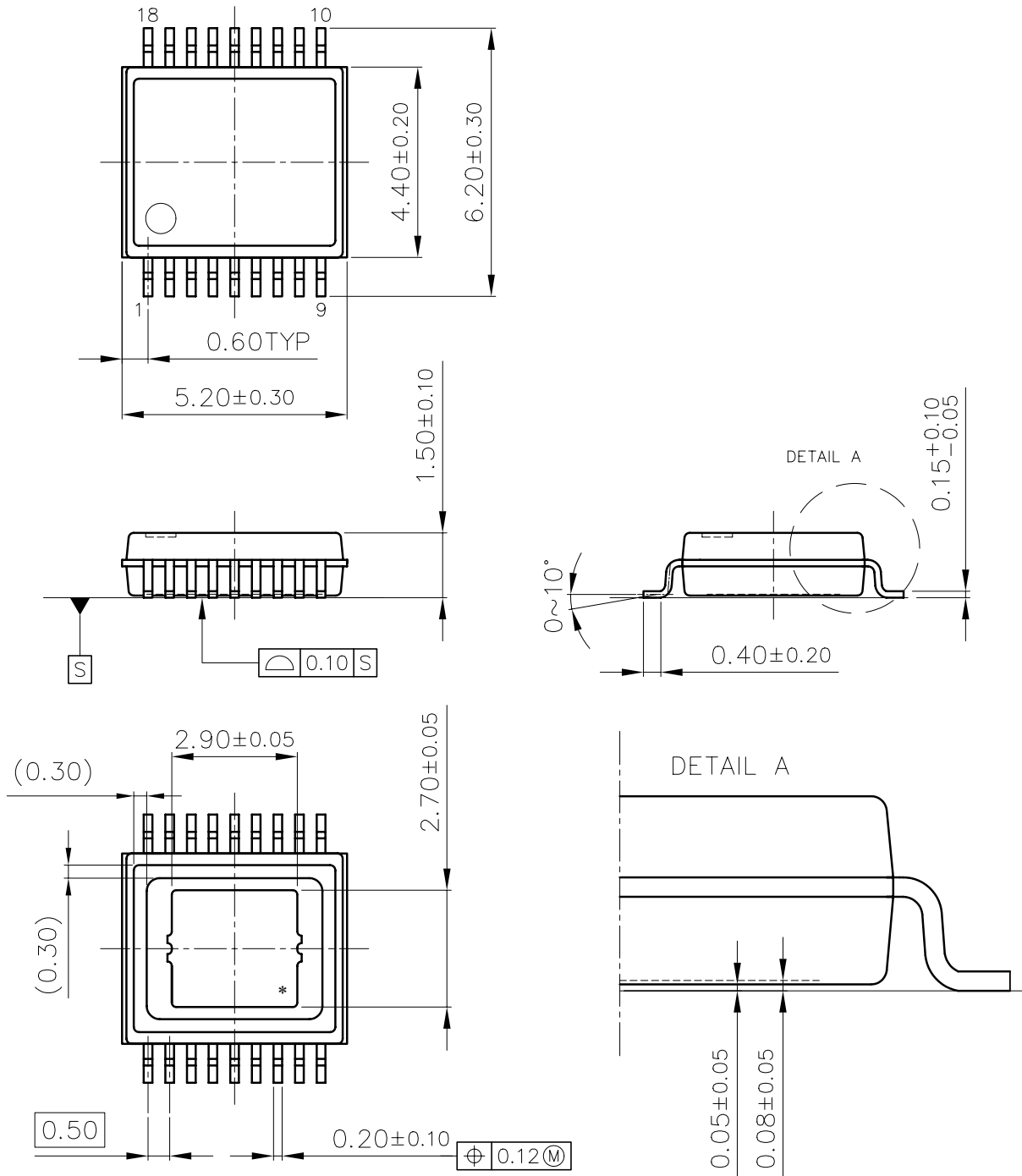

UNIT: mm

HSOP-18 Package Dimensions

①②③④⑤⑥: Product Code ... Refer to *Part Marking List*

⑦⑧⑨: Lot Number ... Alphanumeric Serial Number

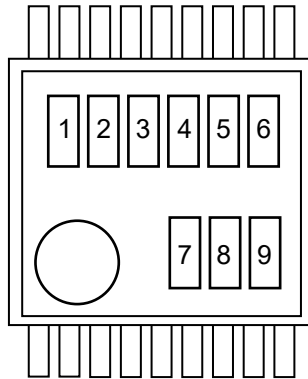

R3500S (HSOP-18) Part Markings

NOTICE

There can be variation in the marking when different AOI (Automated Optical Inspection) equipment is used. In the case of recognizing the marking characteristic with AOI, please contact our sales or distributor before attempting to use AOI.

R3500S Part Marking List

Product Name	①	②	③	④	⑤	⑥	⑦	⑧	⑨
R3500S001A	R	S	1	3	8	A	Lot. No.		
R3500S002A	R	S	1	3	8	B	Lot. No.		
R3500S003A	R	S	1	3	8	C	Lot. No.		
R3500S004A	R	S	1	3	8	D	Lot. No.		
R3500S005A	R	S	1	3	8	E	Lot. No.		
R3500S006A	R	S	1	3	8	F	Lot. No.		
R3500S007A	R	S	1	3	8	G	Lot. No.		
R3500S008A	R	S	1	3	8	H	Lot. No.		
R3500S009A	R	S	1	3	8	J	Lot. No.		
R3500S010A	R	S	1	3	8	K	Lot. No.		
R3500S011A	R	S	1	3	8	L	Lot. No.		

1. The products and the product specifications described in this document are subject to change or discontinuation of production without notice for reasons such as improvement. Therefore, before deciding to use the products, please refer to our sales representatives for the latest information thereon.
2. The materials in this document may not be copied or otherwise reproduced in whole or in part without the prior written consent of us.
3. This product and any technical information relating thereto are subject to complementary export controls (so-called KNOW controls) under the Foreign Exchange and Foreign Trade Law, and related politics ministerial ordinance of the law. (Note that the complementary export controls are inapplicable to any application-specific products, except rockets and pilotless aircraft, that are insusceptible to design or program changes.) Accordingly, when exporting or carrying abroad this product, follow the Foreign Exchange and Foreign Trade Control Law and its related regulations with respect to the complementary export controls.
4. The technical information described in this document shows typical characteristics and example application circuits for the products. The release of such information is not to be construed as a warranty of or a grant of license under our or any third party's intellectual property rights or any other rights.
5. The products listed in this document are intended and designed for use as general electronic components in standard applications (office equipment, telecommunication equipment, measuring instruments, consumer electronic products, amusement equipment etc.). Those customers intending to use a product in an application requiring extreme quality and reliability, for example, in a highly specific application where the failure or misoperation of the product could result in human injury or death should first contact us.
 - Aerospace Equipment
 - Equipment Used in the Deep Sea
 - Power Generator Control Equipment (nuclear, steam, hydraulic, etc.)
 - Life Maintenance Medical Equipment
 - Fire Alarms / Intruder Detectors
 - Vehicle Control Equipment (automotive, airplane, railroad, ship, etc.)
 - Various Safety Devices
 - Traffic control system
 - Combustion equipment

In case your company desires to use this product for any applications other than general electronic equipment mentioned above, make sure to contact our company in advance. Note that the important requirements mentioned in this section are not applicable to cases where operation requirements such as application conditions are confirmed by our company in writing after consultation with your company.

6. We are making our continuous effort to improve the quality and reliability of our products, but semiconductor products are likely to fail with certain probability. In order to prevent any injury to persons or damages to property resulting from such failure, customers should be careful enough to incorporate safety measures in their design, such as redundancy feature, fire containment feature and fail-safe feature. We do not assume any liability or responsibility for any loss or damage arising from misuse or inappropriate use of the products.
7. The products have been designed and tested to function within controlled environmental conditions. Do not use products under conditions that deviate from methods or applications specified in this datasheet. Failure to employ the products in the proper applications can lead to deterioration, destruction or failure of the products. We shall not be responsible for any bodily injury, fires or accident, property damage or any consequential damages resulting from misuse or misapplication of the products.
8. **Quality Warranty**
 - 8-1. **Quality Warranty Period**

In the case of a product purchased through an authorized distributor or directly from us, the warranty period for this product shall be one (1) year after delivery to your company. For defective products that occurred during this period, we will take the quality warranty measures described in section 8-2. However, if there is an agreement on the warranty period in the basic transaction agreement, quality assurance agreement, delivery specifications, etc., it shall be followed.
 - 8-2. **Quality Warranty Remedies**

When it has been proved defective due to manufacturing factors as a result of defect analysis by us, we will either deliver a substitute for the defective product or refund the purchase price of the defective product.

Note that such delivery or refund is sole and exclusive remedies to your company for the defective product.
 - 8-3. **Remedies after Quality Warranty Period**

With respect to any defect of this product found after the quality warranty period, the defect will be analyzed by us. On the basis of the defect analysis results, the scope and amounts of damage shall be determined by mutual agreement of both parties. Then we will deal with upper limit in Section 8-2. This provision is not intended to limit any legal rights of your company.
9. Anti-radiation design is not implemented in the products described in this document.
10. The X-ray exposure can influence functions and characteristics of the products. Confirm the product functions and characteristics in the evaluation stage.
11. WLCSP products should be used in light shielded environments. The light exposure can influence functions and characteristics of the products under operation or storage.
12. Warning for handling Gallium and Arsenic (GaAs) products (Applying to GaAs MMIC, Photo Reflector). These products use Gallium (Ga) and Arsenic (As) which are specified as poisonous chemicals by law. For the prevention of a hazard, do not burn, destroy, or process chemically to make them as gas or power. When the product is disposed of, please follow the related regulation and do not mix this with general industrial waste or household waste.
13. Please contact our sales representatives should you have any questions or comments concerning the products or the technical information.



Nisshinbo Micro Devices Inc.

Official website

<https://www.nisshinbo-microdevices.co.jp/en/>

Purchase information

<https://www.nisshinbo-microdevices.co.jp/en/buy/>