

Discontinued

- **Balanced Differential Inputs, 80 dB CMR Noise Rejection**
- **Autozeroing, Ratiometric Reference for Drift Correction**
- **1000 MΩ CMOS High Impedance Inputs**
- **Display - .56" High Numerals Red LED**
- **Compact, Short Depth Case - 3.00"W x 2.15"D x 1.76"H (76,2 x 54,6 x 44,7 mm)**

APPLICATIONS

- **Ammeter** - Accepts user-supplied shunts for ±20 μA to ±2A Full Scale Ranges
- **Voltmeter** - Accepts user-supplied attenuators for ±2V to ±1 kV Full Scale Ranges
- **Ohmmeter** - 200Ω to 10MΩ Full Scale Range



DESCRIPTION

The DM-3100B is a very low cost, dual AC-powered Digital Panel Meter. Analog voltages over the range of ±1.999 Vdc are displayed with 3½ digits of resolution. The DM-3100B is powered from the AC line; 115 or 230 VAC is pin-selectable. The unit can provide +5V and -5 Vdc (@ 100 milliamps and 5 milliamps respectively) to power customer-supplied external circuitry.

The DM-3100B uses a self-illuminated red LED display with .56" high numerals. It is clearly visible from many feet away in normal or dim light.

Inputs to the DM-3100B are balanced differential (80 dB Common Mode Rejection) so the meter will accurately display small signals even in electrically noisy industrial environments. CMOS circuitry results in an extremely high input impedance (1000 Megohms, typically) and a very low bias current of 5 picoamps - inputs with a source impedance as high as 100 kilohms can be displayed with accuracy. The input circuitry will also safely tolerate over-voltages up to ±250 Vdc (155 VRMS). Inputs are sampled and displayed about four times per second.

Autozeroing and a ratiometric reference in-out loop permit the DM-3100B to be used for drift correction in bridge-type measurement systems. Meter accuracy is adjustable to ±1/10% (±1 count). Temperature drift of zero is ±1 count from 0 to 50°C, while temperature drift of gain runs typically ±50 ppm of Reading/°C.

The AC-powered DM-3100B was designed for installations where existing dc supplies are noisy, inaccessible, or overloaded. This meter may be used wherever a voltage, or a unit which can be made proportional to voltage, must be displayed with accuracy and clarity. The basic input range of ±1.999 Vdc can be expanded with a simple voltage divider to display voltages up to ±1kV or up to ±2A using current shunts. Blank pads on the meter's circuit board can accept user-supplied voltage attenuator resistors, current shunts, or digital ohmmeter components.

The DM-3100B is supplied in MPS's standard short depth black polycarbonate case, measuring only 3.00"W x 2.15"D x 1.76"H. All connections are made on the back panel to an optional 18-pin edge connector. Cutout dimensions are 1.812"H x 3.062"W (46,0 x 77,8 mm), minimum.

Note: DPM's are supplied without bezel labels and logos.

SIMPLIFIED BLOCK DIAGRAM

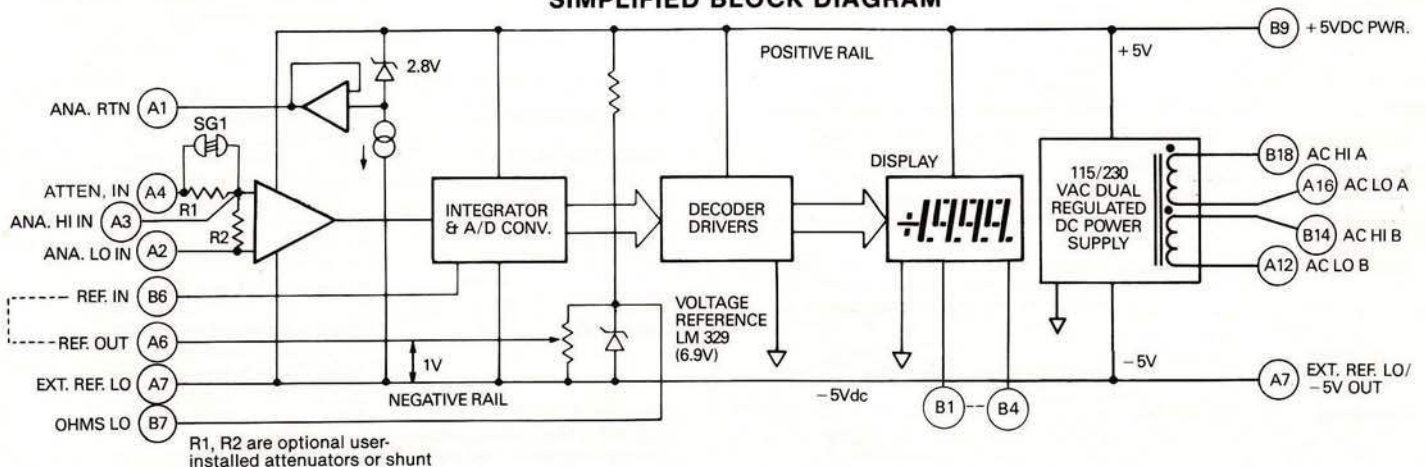

MODEL DM-3100B

SPECIFICATIONS, DM-3100B (Typical @ +25°C, unless noted)

ANALOG INPUT

Configuration	True, balanced differential bipolar -1.999 Vdc to +1.999 Vdc Input pad area will accept user- installed range change
Input Bias Current	5 pA typical, 50 pA maximum
Displayed Accuracy @ +25°C	Adjustable to ±0.1% reading, ±1 count
Resolution	1 mV
Temperature Drift of Zero	Autozeroed ±1 count over 0 to +50°C
Temperature Drift of Gain	±50 ppm of Reading/°C typ. ±100 ppm of Reading/°C max.
Input Impedance	100 Megohms, minimum
Input Overvoltage	±250 Volts dc, 155 VRMS con- tinuous max. ±300 Volts intermittent max.
Common Mode Rejection	80 dB, DC to 60 Hz, 1 Kilohm un- balance
Common Mode Voltage Range	Within +Vs - .5V and -Vs +1V where +Vs is the positive rail (Pin B9) and -Vs is the negative rail (Pin A7)). -Vs is approximately equal to -5V below PWR. COM. (Pin A9)
Warm-Up Time	Within 10 minutes
Reference	Internal, referred to the negative rail (-Vs). External, user-supplied reference optional for ratiometric operation.
External Ref. Range	+100 mV to 2V, referred to -Vs
Ramp-up Time (Integration Period)	83.3 mS

DISPLAY

Number of Digits	3 decimal digits and most significant "1" digit (3½ digits)
Decimal Points	Selectable decimal points are in- cluded for scale multipliers.
Display Type	Red, light-emitting diode (LED) self illuminated.
Display Height	0.56 inches (14,2 mm)
Overscale	Inputs exceeding the full scale range blank the display, leaving a "1" MSD and sign.
Autopolarity	A minus sign is automatically dis- played for negative inputs, and may also be blanked
Sampling Rate	Factory set at 3 conversions per second. May be rewired up to 20 conversions/second.

I/O CONNECTIONS

Analog HI Input (Pin A3)	Differential input voltages are con- nected between these inputs. A bias current path to POWER COMMON (if ±5V-powered) or ANALOG RETURN from both these inputs must be exter- nally provided. External circuits must constrain these inputs to be within the common mode voltage range.
Analog LO Input (Pin A2)	
Attenuator IN (Pin A4)	Connected in series through R1 (Optional attenuator resistor) to Ana. HI In (Pin A3). Supplied with a jumper in place of R1.
Analog Return (Pin A1)	This pin may be used as a low-noise bias current return for some floating inputs. If not possible, inputs may be referenced to POWER COMMON (if ±5V-powered). Analog Return is approximately -2.8V below +Vs and can sink 30 mA to -Vs.
Reference In/Out (Pins B6/A6)	Normally, REF. IN and REF. OUT should be jumpered together. An external floating source referred to EXT. REF. LO (Pin A7) may be sub- stituted for ratiometric operation.

Decimal Points	Connect selected pin to DECIMAL POINT COMMON (Pin B5)
Display Test (Pin A5)	Connect this input to +5 Vdc (Pin B9) to light all display segments.
Polarity Enable (Pin A8)	Ground this input to Pin A9 to auto- matically display a minus sign for negative inputs.
Ohms Lo (Pin B7)	This connection is used in the ohm- meter configuration, otherwise do not use

POWER CONNECTIONS

- For 115 VAC input: (parallel both windings)
1. Connect AC LINE HI A (Pin B18) to AC LINE HI B (Pin B14). Connect both to the hot side of the AC line (mains).
 2. Connect AC LINE LO A (Pin A16) to AC LINE LO B (Pin A12). Connect both to the neutral side of the AC line (mains).
- For 230 VAC input: (Series both windings)
1. Connect AC LINE HI B (Pin B14) to AC LINE LO A (Pin A16). Make no other connections to these two leads.
 2. Connect AC LINE HI A (Pin B18) to the hot side of the AC line (mains).
 3. Connect AC LINE LO B (Pin A12) to the neutral side of the AC line (mains).
- DC Power Ground (Pin A9) may be connected to earth ground if input circuits permit.
- For DC-Power Only:
A bipolar ±5V power supply or two isolated single supplies are required. Connect +5V to Pin B9, -5V to Pin A7 and Power Ground to Pin A9

POWER REQUIREMENTS

AC Power	115 or 230 VAC, ±10%, 47 to 440 Hz, 4 watts typical
DC Power	+5V ±0.25 Vdc @ 250 mA typical, 400 mA max. and -5V Vdc @ 5 mA typ, 25 mA max. Logic spikes must be less than 50 mV. Bypass supplies externally if necessary.
Calibration	A multiturn screwdriver pot adjusts the full scale reading (gain). Zero is automatic (autozeroing). Suggested recalibration in stable conditions is 90 days.

PHYSICAL-ENVIRONMENTAL

Short-Depth Case	Interchangeable with other Datel cases.
Outline Dimensions	3.00"W x 2.15"D x 1.76"H (76,2 x 54,6 x 44,7 mm)
Cutout Dimensions	1.81 2"H x 3.062"W (46,0 x 77,7 mm)
Mounting Method	Through a front panel cutout secured by (4) 4-40 front access screws which are concealed by the bezel.
Weight	Approximately 5 ounces (142g)
Connector	Double-sided edgeboard PC type, solder tab, gold-plated fingers, Dual 18-pin, 0.100" centers, Datel #58-2075010, (not included)
Mounting Position	Any
Operating Temperature Range	0 to +50°C
Storage Temperature Range	-25 to +85°C
Altitude	0 to 15,000 feet (4600m)
Relative Humidity	20% to 80% non-condensing

DM-3100B COMPONENT LOCATIONS*

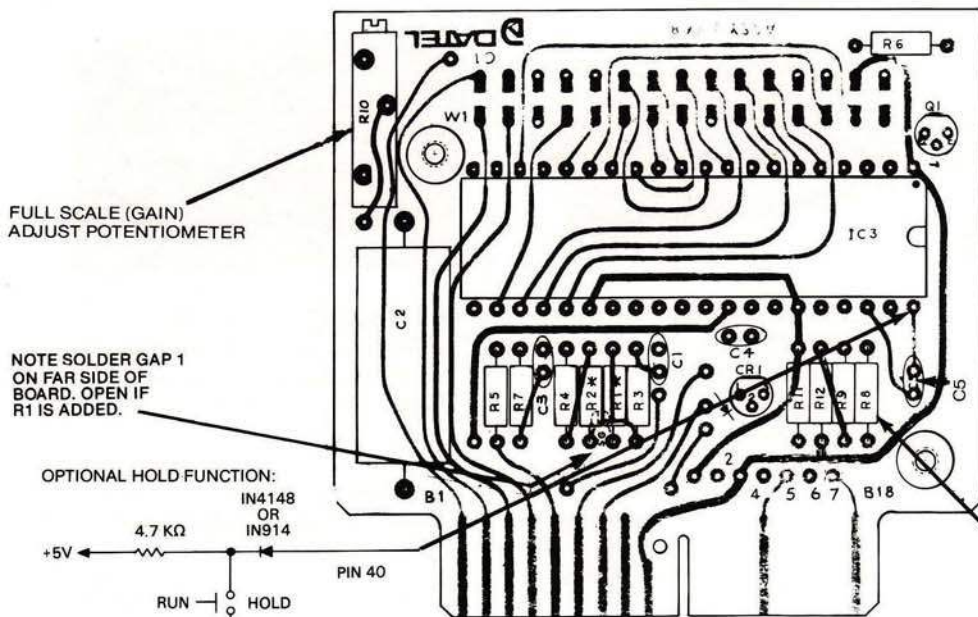

* Refer to MPS RN-3100/4100 Range-Change Accessory Kit data sheet for detailed modification instructions and R1 & R2 locations.

FULL SCALE (GAIN) ADJUST POTENTIOMETER

NOTE SOLDER GAP 1 ON FAR SIDE OF BOARD. OPEN IF R1 IS ADDED.

OPTIONAL HOLD FUNCTION:

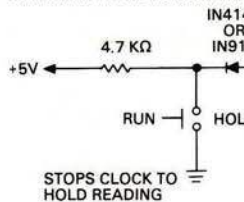

Some versions of the DM-3100B have solder gaps on the bottom of the converter board, rather than a jumper at R1. Before attenuating resistors can be added to the DM-3100B, this solder gap must be opened with a soldering iron.

RC OSCILLATOR
R8 (100KΩ)

$$R8 (K\Omega) = \frac{3 \times 10^4}{\text{SAMPLE RATE}} \times C5(pF)$$

R8 MAY BE TRIMMED FOR EXACTLY 48 KHZ ON IC PIN 38 (MEASURE WITH LOW CAPACITY PROBE) FOR BEST 60 HZ NOISE REJECTION. FOR 50 HZ, USE 120 pF AT C5 RETRIM. REDUCE R8 FOR FASTER SAMPLING.

INPUT/OUTPUT CONNECTIONS WITH SINGLE-ENDED INPUT

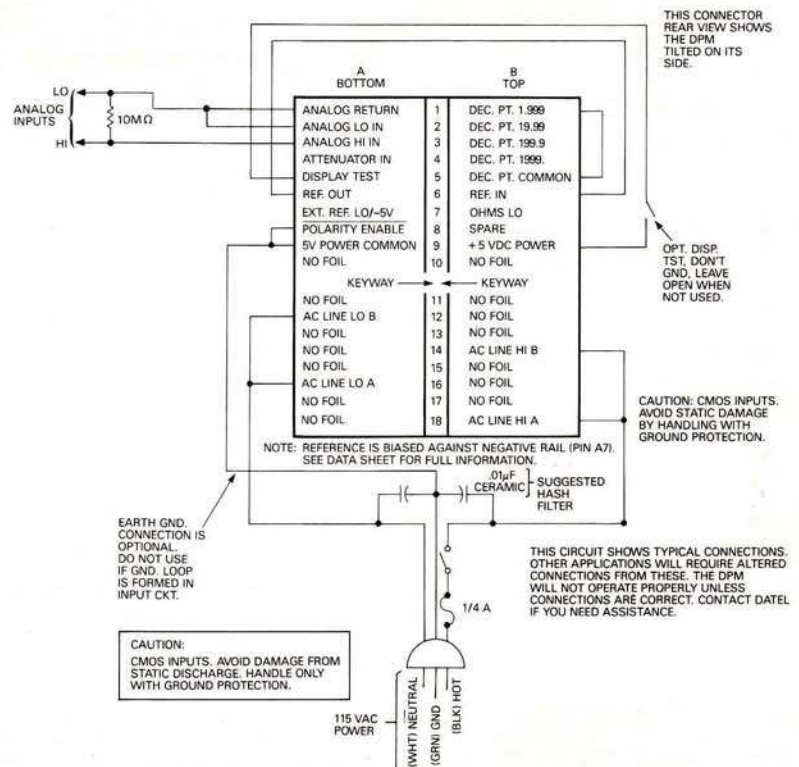

DECIMAL POINT WIRING

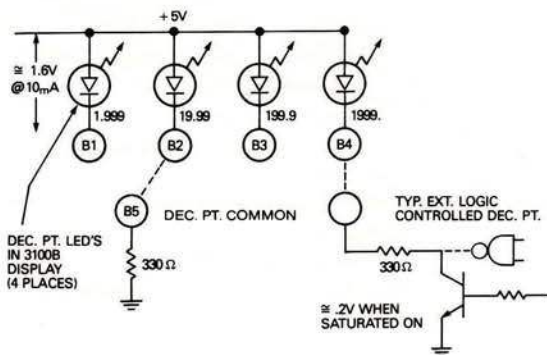

Ordering Information

DM-3100B-1: ± 2Vdc Input Range (Supplied With Free Connector)
RN-3100/4100: Range-Change Accessory Kit for DM-Series Meters

**MECHANICAL DIMENSIONS
INCHES (MM)**

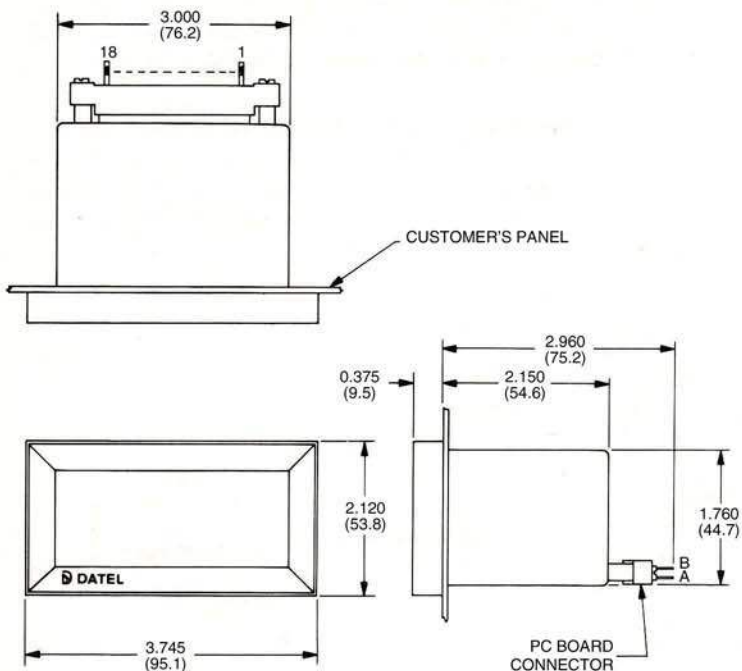

DWG. C-1561-4

PANEL MOUNTING

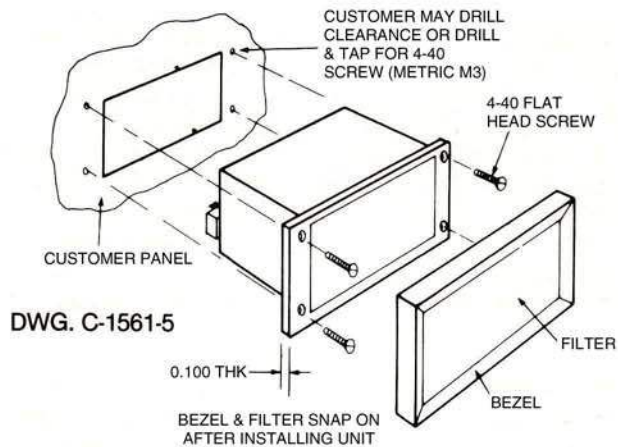

DWG. C-1561-5

**SHORT DEPTH CASE
INCHES (MM)**

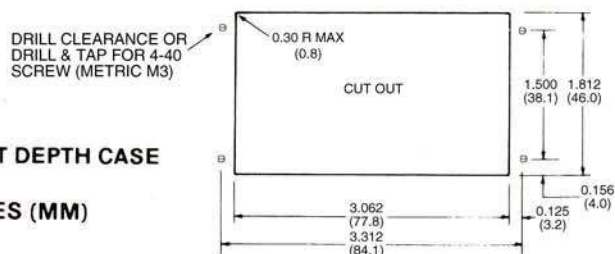

DWG. C-1561-3

SINGLE-ENDED INPUT WITH GAIN

The internal power supply of the DM-3100B can be used to power external circuitry. The drawing below shows an op amp—user-supplied—in a single-ended configuration to provide gain for a low level input. Power is from the +5V and -5V power in connections (B9 and A7, respectively) on

the DM-3100B. Where low level signals will be amplified, it is important to pay attention to ground routing. A single common ("Mecca") ground point, as indicated in the diagram, is recommended.

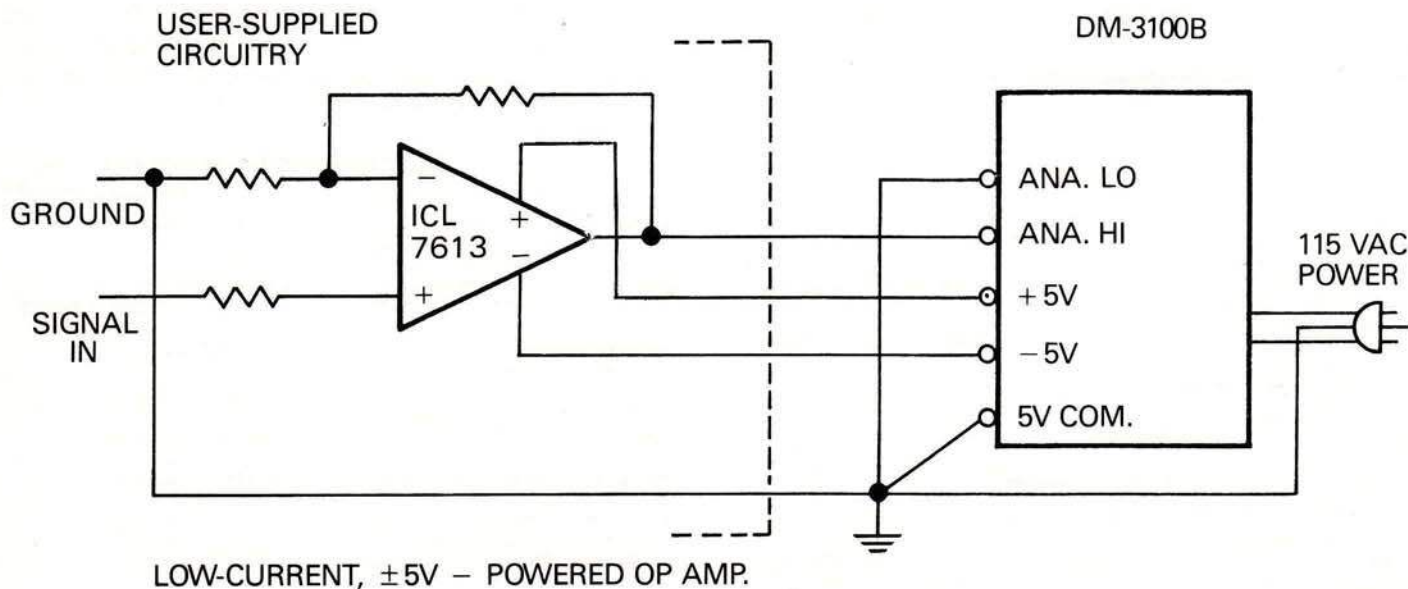

LOW-CURRENT, ±5V – POWERED OP AMP.

APPLICATIONS

RATIOMETRIC CONNECTIONS WITH BRIDGE INPUTS

The DM-3100B has a reference in-out loop which makes possible ratiometric measurements. Representative connections are illustrated below. Ratiometric operation eliminates changes in the DPM reading due to voltage variations in the Bridge's external excitation source. The input gain on the DM-3100B varies inversely with voltage at Reference In — as REF IN voltage increases, meter gain decreases. Meter input gain thus can be made to compensate for variations in the bridge excitation source voltage. (The DPM is set for unity gain when REF IN V equals +1V as referred to $-V_s$).

For all applications, $V_{IN} = 2 V_{REF}$ at full scale (1999 counts). For small values of V_{REF} (100 mV or lower), increased display noise, nonlinearity, rollover and CMR errors will be apparent. Avoid V_{REF} inputs beyond about 2V to prevent inte-

grator saturation with full scale inputs. Variable V_{REF} is not intended for wide gain changes as in multimeter applications. Instead, it should be used for drift correction, scaling to engineering units, or for modest amounts of gain.

A note on grounding: The DM-3100B's internal voltage reference source is biased against the internal negative supply rail ($-V_s$). Note that this is *not* the same electrical connection as the 5V Power Common connection. Refer to the Simplified Block Diagram.

Because of this configuration, external reference sources should be isolated from the 5V Power Common and should have the Reference Lo Output from the external source connected to the negative supply rail.

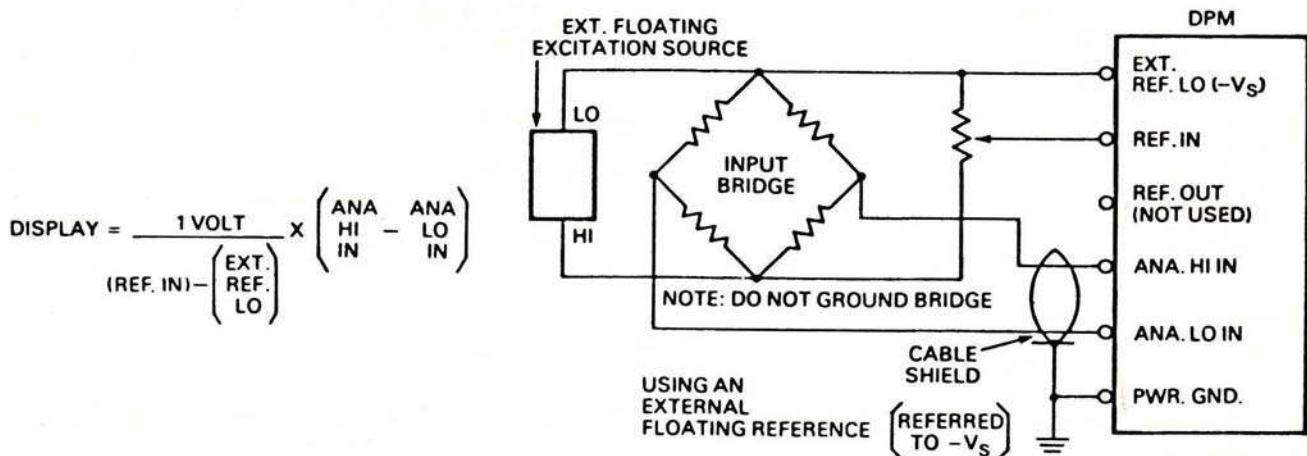

DIGITAL OHMMETER CONNECTIONS

The digital ohmmeter circuit uses the DM-3100B's ratio-metric capability. An external reference resistor of known resistance, accuracy, and temperature drift is connected in series with the unknown resistance. A constant, stable volt-

age from the DPM's internal reference diode is applied to the resistor pair to produce a constant current. This current develops two voltage drops across the resistors which are proportional only to the ratio of the resistances since the current through them is identical.

The chart below lists recommended R_{REF} and R_{LIMIT} resistance values corresponding to different ohmmeter ranges. Values of R_{LIMIT} were selected to limit the current through R_{REF} and R_X to 1 milliampere maximum.

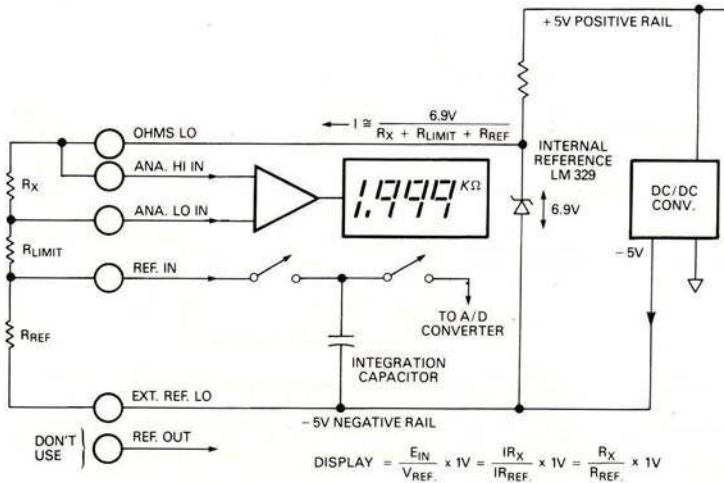

RANGE	RESOLUTION	R _{LIMIT}	R _{REF}	DECIMAL POINT
19.99 MΩ	10 kΩ	22 MΩ	10 MΩ	B2 to B5
1.999 MΩ	1 kΩ	3.6 MΩ	1 MΩ	B1 to B5
199.9 kΩ	100 Ω	360 kΩ	100 kΩ	B3 to B5
19.99 kΩ	10 Ω	36 kΩ	10 kΩ	B2 to B5
1.999 kΩ	1 Ω	6.2 kΩ	1 kΩ	B1 to B5

Murata Power Solutions, Inc.
 11 Cabot Boulevard, Mansfield, MA 02048-1151 U.S.A.
 ISO 9001 and 14001 REGISTERED



This product is subject to the following operating requirements and the Life and Safety Critical Application Sales Policy:
 Refer to: <http://www.murata-ps.com/requirements/>

Murata Power Solutions, Inc. makes no representation that the use of its products in the circuits described herein, or the use of other technical information contained herein, will not infringe upon existing or future patent rights. The descriptions contained herein do not imply the granting of licenses to make, use, or sell equipment constructed in accordance therewith. Specifications are subject to change without notice. © 2015 Murata Power Solutions, Inc.