

MAX1614

High-Side, n-Channel MOSFET Switch Driver

General Description

The MAX1614 drives high-side, n-channel power MOSFETs to provide battery power-switching functions in portable equipment. The n-channel power MOSFETs typically have one-third the on-resistance of p-channel MOSFETs of similar size and cost. An internal micropower regulator and charge pump generate the high-side drive output voltage, while requiring no external components.

The MAX1614 also features a 1.5%-accurate low-battery comparator that can be used to indicate a low-battery condition, provide an early power-fail warning to the system microprocessor, or disconnect the battery from the load, preventing deep discharge and battery damage. An internal latch allows for pushbutton on/off control with very low current consumption. Off-mode current consumption is only 6µA while normal operation requires less than 25µA. The MAX1614 is available in the space-saving µMAX[®] package that occupies about 60% less space than a standard 8-pin SO.

Applications

- Notebook Computers
- Portable Equipment
- Hand-Held Instruments
- Battery Packs

Typical Operating Circuit

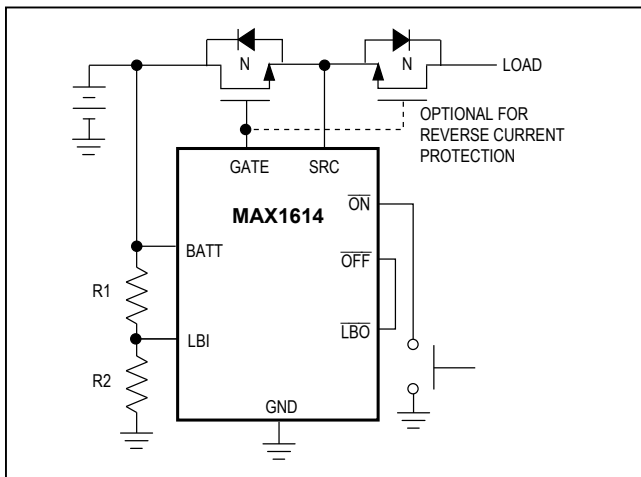

µMAX is a registered trademark of Maxim Integrated Products, Inc.

Benefits and Features

- Integration Provides a Simple-to-Use Solution
 - Requires No External Components
 - Internal On/Off Latch Facilitates Pushbutton Control
 - 1.5% Accurate Low-Battery Detector Protects Battery and Data Stored in Memory
 - Controlled Turn-On for Low Inrush Current
- Low Power Consumption Extends Battery Life
 - 25µA (max) Quiescent Current
 - 6µA (max) Shutdown Current
- µMAX Package is 60% Smaller Than Typical 8-Pin SO Solution
- Supports Typical Requirements of Portable, Battery-Powered Designs
 - 5V to 26V Input Voltage Range
 - Drives Single or Back-to-Back MOSFETs

Ordering Information

PART	TEMP RANGE	PIN-PACKAGE
MAX1614C/D	0°C to +70°C	Dice*
MAX1614EUA+	-40°C to +85°C	8 µMAX

*Contact factory for dice specifications.

+Denotes a lead(Pb)-free/RoHS-compliant package.

Devices are also available in a tape-and-reel package.

Specify tape-and-reel by adding "T" to the part number when µMAX is a registered trademark of Maxim Integrated Products, Inc. ordering.

Pin Configuration

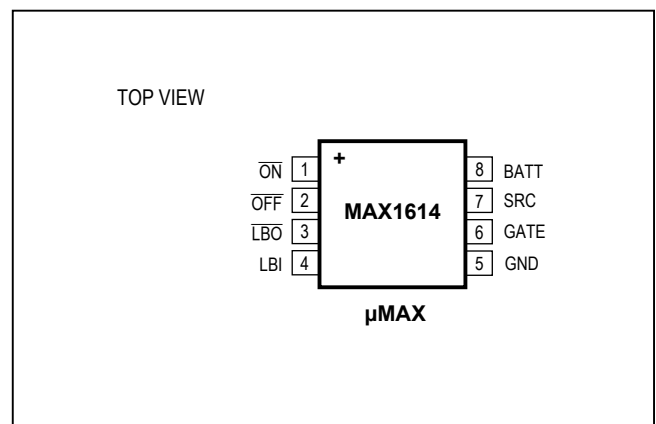

Absolute Maximum Ratings

BATT, SRC to GND.....	-0.3V to +30V	Continuous Power Dissipation (T _A = +70°C)
GATE to SRC.....	-0.3V to +12V	μMAX (derate 4.10mW/°C above +70°C).....
GATE to GND	-0.3V to +36V	330mW
GATE + SRC Sink Current, Continuous	2.7mA	Operating Temperature Range
LBI, LBO, ON, OFF to GND.....	-0.3V to +12V	-40°C to +85°C
LBO Current	5mA	Junction Temperature.....
		+150°C
		Storage Temperature Range
		-65°C to +160°C
		Lead Temperature (soldering, 10s)
		+300°C
		Soldering Temperature (reflow)
		+260°C

Stresses beyond those listed under "Absolute Maximum Ratings" may cause permanent damage to the device. These are stress ratings only, and functional operation of the device at these or any other conditions beyond those indicated in the operational sections of the specifications is not implied. Exposure to absolute maximum rating conditions for extended periods may affect device reliability.

Electrical Characteristics

(V_{BATT} = 15V, T_A = 0°C to +85°C, unless otherwise noted. Typical values are at T_A = +25°C.)

PARAMETER	SYMBOL	CONDITIONS	MIN	TYP	MAX	UNITS
BATT Operating Range		V _{GATE} - V _{SRC} > 3V, SRC = BATT	5		26	V
BATT Shutdown Current	I _{SHDN}	V _{BATT} = 26V, ON = OFF = unconnected, I _{GATE} = 0A, device latched off, V _{LBI} = 1.5V		4	7	μA
Quiescent Current	I _{BATT} + I _{SRC}	V _{BATT} = 15V, ON = OFF = unconnected, I _{GATE} = 0A, device latched on, V _{LBI} = 1.5V, SRC = BATT		17	30	μA
		V _{BATT} = 26V, ON = OFF = unconnected, I _{GATE} = 0A, device latched on, V _{LBI} = 1.5V, SRC = BATT		21	40	
INTERNAL CHARGE PUMP						
GATE-Drive Voltage	V _{GS}	Measured from GATE to SRC, V _{BATT} = 15V, I _{GATE} = 0A	6.5	8	9.0	V
		Measured from GATE to SRC, V _{BATT} = V _{SRC} = 5V, I _{GATE} = 1.5μA	3			
GATE-Drive Output Current		V _{GATE} = V _{SRC} = 15V	15		60	μA
GATE-Discharge Current		V _{GATE} = 4V, device latched off	0.5		2	mA
LOW-BATTERY COMPARATOR						
LBI Trip Level	V _{TH}	LBI input falling	1.182	1.20	1.218	V
LBI Trip Hysteresis				0.02V _{TH}		V
Minimum V _{BATT} for Valid LBO		Tested at V _{LBI} = V _{BATT} /4		0.9	4	V
LBI Input Current	I _{LBI}	V _{LBI} = 1.3V			10	nA
LBO Low Voltage	V _{OL}	I _{SINK} = 1mA			0.4	V
LBO High Leakage	V _{OH}	V _{LBO} = 11.5V			0.5	μA
CONTROL INPUTS (ON, OFF)						
Minimum Input Pullup Current		Tested at 2V	0.5			μA
Maximum Input Pullup Current		Tested at 0.6V		1.5	2	μA
Input Low Voltage	V _{IL}	V _{BATT} = 5V			0.6	V
Input High Voltage	V _{IH}	V _{BATT} = 26V	2.0			V
Minimum Input Pulse Width	t _{PW}	V _{BATT} = 5V		0.5	1.0	μs

Electrical Characteristics

($V_{BATT} = 15V$, $T_A = -40^{\circ}C$ to $+85^{\circ}C$, unless otherwise noted. (Note 1))

PARAMETER	SYMBOL	CONDITIONS	MIN	TYP	MAX	UNITS
BATT Operating Range		$V_{GATE} - V_{SRC} > 3V$, SRC = BATT	5.0		26	V
BATT Shutdown Current	I_{SHDN}	$V_{BATT} = 26V$, $\overline{ON} = \overline{OFF} =$ unconnected, $I_{GATE} = 0A$, device latched off, $V_{LBI} = 1.5V$			8	μA
Quiescent Current	$I_{BATT} + I_{SAC}$	$V_{BATT} = 26V$, $\overline{ON} = \overline{OFF} =$ unconnected, $I_{GATE} = 0A$, device latched on, $V_{LBI} = 1.5V$			40	μA
INTERNAL CHARGE PUMP						
GATE-Drive Voltage	V_{GS}	Measured from GATE to SRC, $V_{BATT} = 15V$, $I_{GATE} = 0A$	6.5		9.0	V
		Measured from GATE to SRC, $V_{BATT} = 5.25V$, $I_{GATE} = 1.5\mu A$, $V_{SRC} = 5.25V$	3			
GATE-Drive Output Current		$V_{GATE} = V_{SRC} = 15V$	15		60	μA
LOW-BATTERY COMPARATOR						
LBI Trip Level	V_{TH}	LBI input falling	1.176	1.20	1.224	V

Note 1: Specifications to $T_A = -40^{\circ}C$ are guaranteed by design and not production tested.

Typical Operating Characteristics

($T_A = +25^{\circ}C$, unless otherwise noted.)

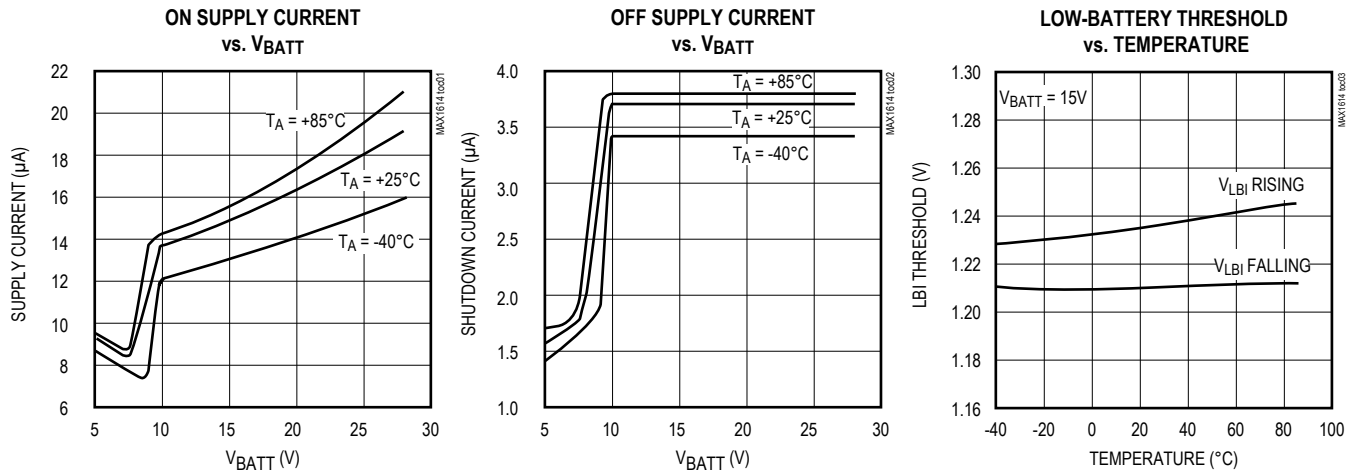

Typical Operating Characteristics (continued)

($T_A = +25^\circ\text{C}$, unless otherwise noted.)

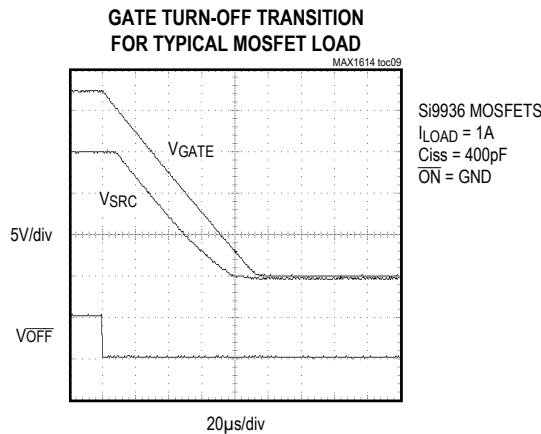
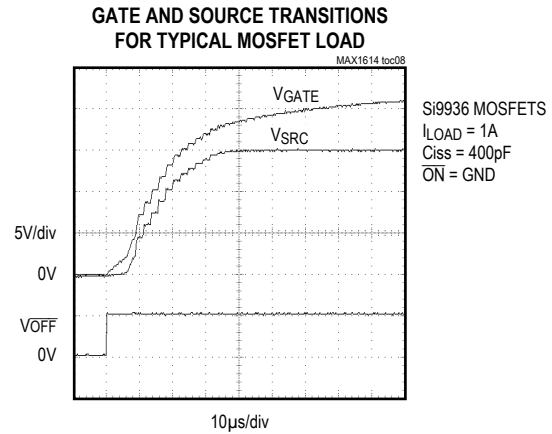
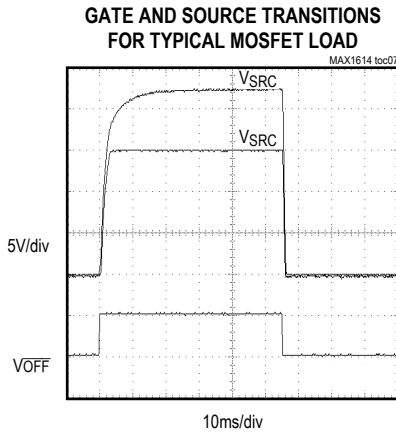
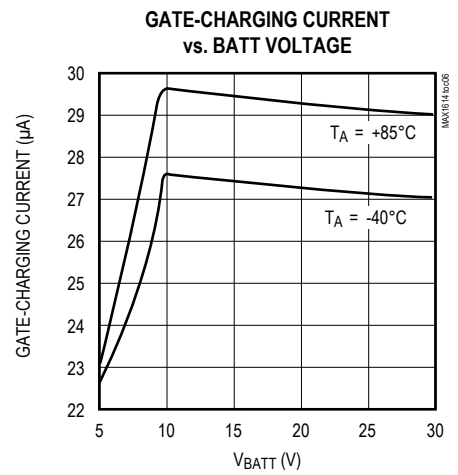
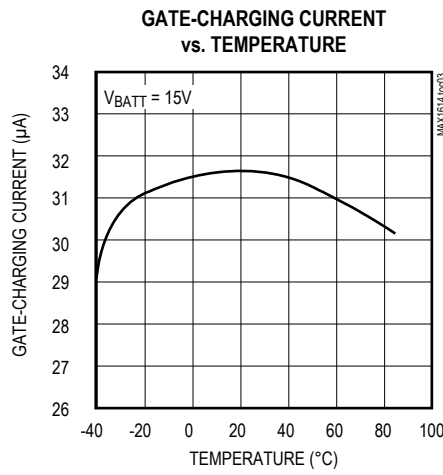
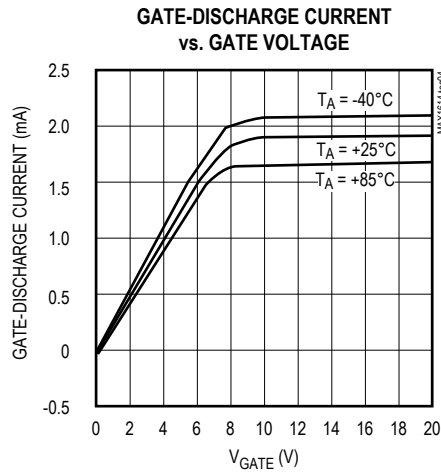

Pin Description

PIN	NAME	FUNCTION
1	$\overline{\text{ON}}$	$\overline{\text{SET}}$ Input to the On/Off Latch. Pulse $\overline{\text{ON}}$ low with $\overline{\text{OFF}}$ high to turn on the external MOSFET switch. When both $\overline{\text{ON}}$ and $\overline{\text{OFF}}$ are low, the part is off.
2	$\overline{\text{OFF}}$	$\overline{\text{RESET}}$ Input to the On/Off Latch. Pulse $\overline{\text{OFF}}$ low with $\overline{\text{ON}}$ high to turn off the external MOSFET switch. When both $\overline{\text{ON}}$ and $\overline{\text{OFF}}$ are low, the part is off.
3	$\overline{\text{LBO}}$	Open-Drain, Low-Battery Comparator Output. $\overline{\text{LBO}}$ is low when V_{LBI} is below the trip point.
4	LBI	Low-Battery Comparator Input. $\overline{\text{LBO}}$ goes low when V_{LBI} falls below 1.20V (typ). Connect a voltage-divider between BATT, LBI, and GND to set the battery undervoltage trip threshold (see <i>Typical Operating Circuit</i>).
5	GND	System Ground
6	GATE	Gate-Drive Output. Connect to the gates of external, n-channel MOSFETs. When the MAX1614 is off, GATE actively pulls to GND.
7	SRC	Source Input. Connect to the sources of external, n-channel MOSFETs. When the MAX1614 is off, SRC actively pulls to GND.
8	BATT	Battery Input. Connect to a battery voltage between 5V and 26V.

Detailed Description

The MAX1614 uses an internal, monolithic charge pump and low-dropout linear regulator to supply the required 8V V_{GS} voltage to fully enhance an n-channel MOSFET high-side switch (Figure 1). The charge pump typically supplies 30 μA , charging 800pF of gate capacitance in 400 μs ($V_{\text{BATT}} = 15\text{V}$). For slower turn-on times, simply add a small capacitor between the GATE and SRC pins. When turned off, GATE and SRC pull low and typically discharge an 800pF gate capacitance in 80 μs .

The MAX1614 provides separate on/off control inputs ($\overline{\text{ON}}$ and $\overline{\text{OFF}}$). $\overline{\text{ON}}$ and $\overline{\text{OFF}}$ connect, respectively, to the $\overline{\text{SET}}$ and $\overline{\text{RESET}}$ inputs of an internal flip-flop. When $\overline{\text{ON}}$ is pulsed low (with $\overline{\text{OFF}} = \text{high}$), the internal charge pump turns on, and GATE is pumped to 8V above SRC, turning on the external MOSFETs. The charge pump maintains gate drive to the external MOSFETs until $\overline{\text{OFF}}$ is pulsed low. When this happens, the internal charge pump turns off, and GATE discharges to ground through an internal switch. For slower turn-on times, simply add a small capacitor.

Applications Information

Connecting $\overline{\text{ON/OFF}}$ to 3V or 5V Logic

$\overline{\text{ON}}$ and $\overline{\text{OFF}}$ internally connect to 2 μA max pullup current sources (Figure 1). The open-circuit voltage for $\overline{\text{ON}}$ and $\overline{\text{OFF}}$ ranges from 7V to 10.5V (nominally 8.5V). Since the current sources are relatively weak, connecting $\overline{\text{ON}}$ and $\overline{\text{OFF}}$ directly to logic powered from lower voltages (e.g.,

3V or 5V) poses no problem if the gate outputs driving these pins can sink at least 2 μA while high.

Although the MAX1614 shutdown function was designed to operate with a single pushbutton on/off switch, it can also be driven by a single gate. Connect $\overline{\text{ON}}$ to GND and drive $\overline{\text{OFF}}$ directly (Figure 2).

Maximum Switching Rate

The MAX1614 is not intended for fast switching applications. In fact, it is specifically designed to limit the rate of change of the load current, $\Delta I/\Delta t$. The maximum switching rate is limited by the turn-on time, which is a function of the charge-pump output current and the total capacitance on GATE (C_{GATE}). Calculate the turn-on time as a function of external MOSFET gate capacitance using the Gate Charging Current vs. V_{BATT} graph in the *Typical Operating Characteristics*. Since turn-off time is small compared to turn-on time, the maximum switching rate is approximately $1/t_{\text{ON}}$.

Adding Gate Capacitance

The charge pump uses an internal monolithic transfer capacitor to charge the external MOSFET gates. Normally, the external MOSFET's gate capacitance is sufficient to serve as a reservoir capacitor. If the MOSFETs are located at a significant distance from the MAX1614, place a local bypass capacitor (100pF typ) across the GATE and SRC pins. For slower turn-on times, simply add a small capacitor between GATE and SRC.

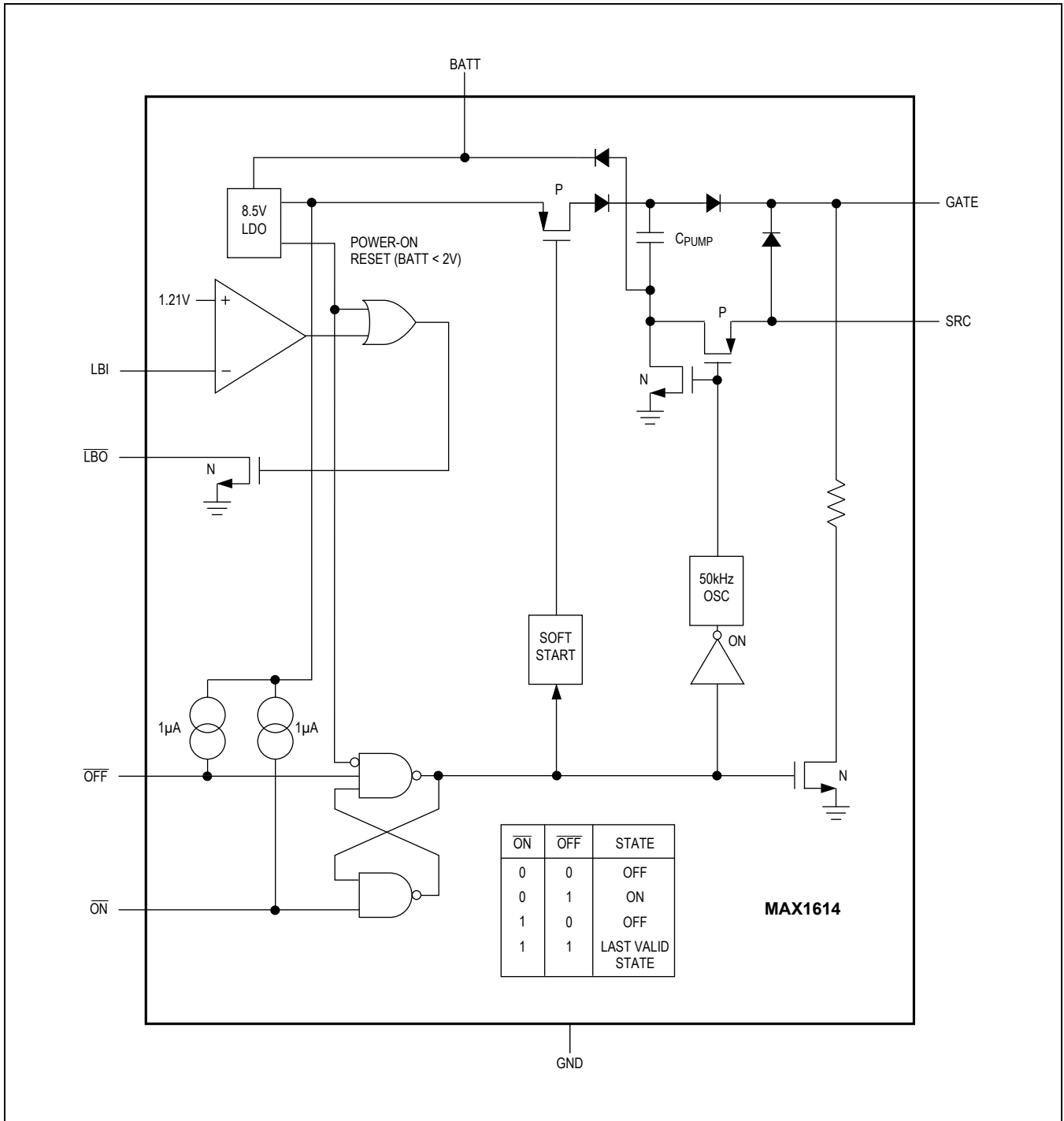

Figure 1. Functional Diagram

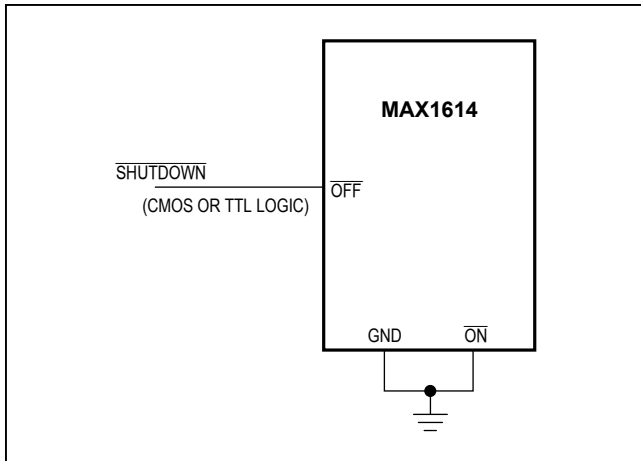

Figure 2. Single-Line Shutdown Control

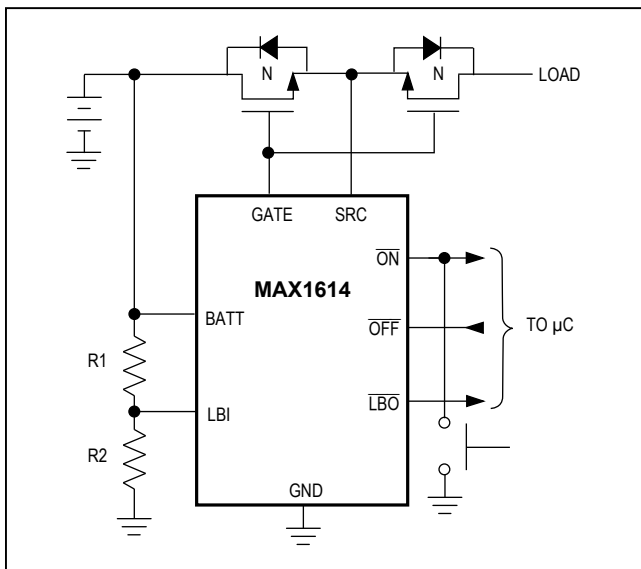

Figure 3. Single-Pushbutton On/Off Control

On/Off Control with a Single Pushbutton Switch

The MAX1614's separate on and off inputs allow maximum flexibility in controlling the external MOSFETs. Connect a pushbutton switch to the $\overline{\text{ON}}$ pin and microcontroller (μC) I/O for single-button control. Connect the $\overline{\text{OFF}}$ pin to another μC I/O pin. On the first button depression, the MAX1614 turns on automatically; the signal is also detected by the μC . When the button is depressed a second time, the μC wraps around and turns off the MAX1614 by pulling low on the $\overline{\text{OFF}}$ pin (Figure 3).

Simple Low-Battery Disconnect/Fresh Battery Reconnect Circuit

A simple undervoltage disconnect circuit is often desirable to prevent damage to secondary batteries due to repeated deep discharge or cell reversal. The *Typical Operating Circuit* turns off the MAX1614, disconnecting the battery from the load when the battery voltage falls below the minimum battery voltage required, ($V_{\text{LOW BATT}}$). $V_{\text{LOW BATT}} = (R1 + R2)/R2 \times V_{\text{TH}}$ where V_{TH} is the LBI input threshold (1.20V typ). When fresh cells are installed or the batteries are recharged, a μC or pushbutton reconnects the load.

Using $\overline{\text{LBO}}$ to Generate Early Power-Fail Interrupt

Many applications require an early warning indicating that power is failing so that the microprocessor (μP) can take care of any "housekeeping" functions (storing current settings in memory, etc.) before the power fails. Connect LBI through a resistor divider across the battery, and connect $\overline{\text{LBO}}$ to the μP nonmaskable interrupt (NMI). Set the threshold so that $\overline{\text{LBO}}$ goes low when the battery decays to a point where regulation begins to degrade (Figure 4). $V_{\text{LOW BATT}} = (R1 + R2)/R2 \times V_{\text{TH}}$, where V_{TH} is the LBI input threshold (1.20V typ). Once housekeeping is complete, the μP can turn off the load by pulling $\overline{\text{OFF}}$ low.

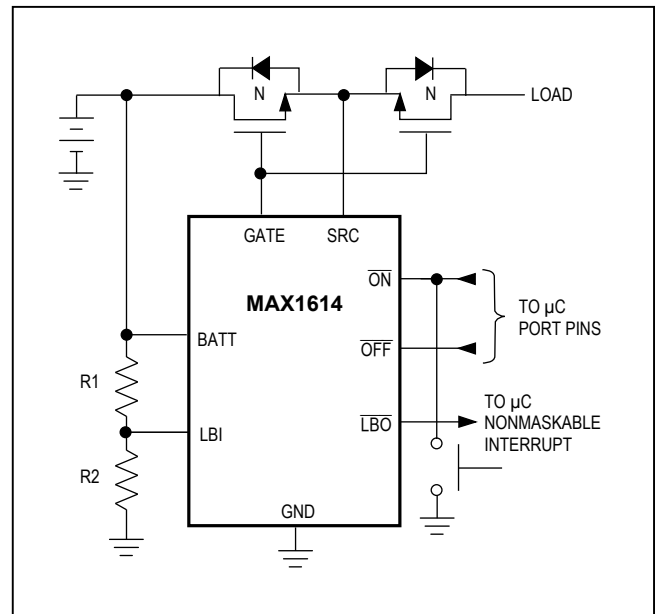

Figure 4. Using $\overline{\text{LBO}}$ to Generate Early Power-Fail Interrupt

Increasing Low-Battery Comparator Hysteresis

The MAX1614 contains an on-chip comparator with 2% hysteresis for low-battery detection. If more than 2% hysteresis is needed on the low-battery comparator and $\overline{\text{LBO}}$ is connected to $\overline{\text{OFF}}$, use the circuit in Figure 5 to add hysteresis. The circuit of Figure 5 shows $\overline{\text{LBO}}$ controlling an n-channel MOSFET that shorts R2 to add positive feedback to the trip point. This is necessary to prevent loading down the 1µA pullup at $\overline{\text{OFF}}$ (Figure 1).

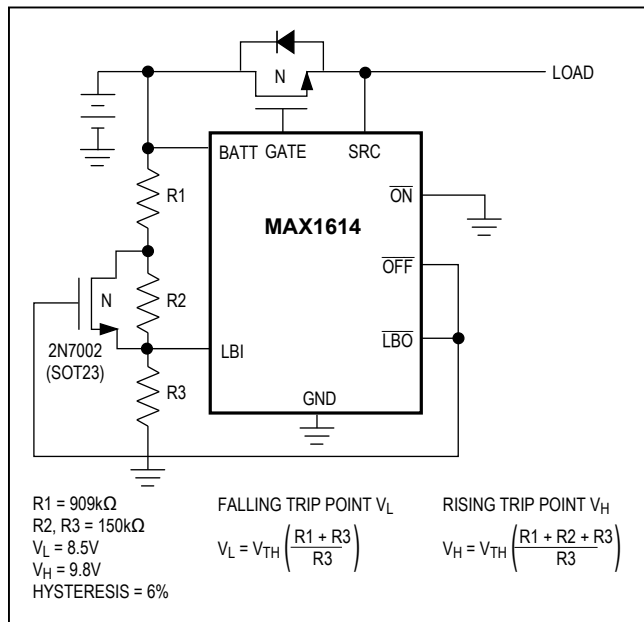

Figure 5. Increasing Hysteresis of the Battery Disconnect Circuit

Chip Information

SUBSTRATE CONNECTED TO GND

Package Information

For the latest package outline information and land patterns (footprints), go to www.maximintegrated.com/packages. Note that a "+", "#", or "-" in the package code indicates RoHS status only. Package drawings may show a different suffix character, but the drawing pertains to the package regardless of RoHS status.

PACKAGE TYPE	PACKAGE CODE	OUTLINE NO.	LAND PATTERN NO.
8 µMAX	U8+1	21-0036	90-0092

Revision History

REVISION NUMBER	REVISION DATE	DESCRIPTION	PAGES CHANGED
0	12/96	Initial release	—
1	6/11	Added automotive-qualified part to the <i>Ordering Information</i> , added soldering temperature to the <i>Absolute Maximum Ratings</i> .	1, 2
2	4/15	Deleted MAX1614EUA/V+ from <i>Ordering Information</i> and <i>IV</i> footnote below table	1
3	5/15	Updated <i>Benefits and Features</i> section	

For pricing, delivery, and ordering information, please contact Maxim Direct at 1-888-629-4642, or visit Maxim Integrated's website at www.maximintegrated.com.

Maxim Integrated cannot assume responsibility for use of any circuitry other than circuitry entirely embodied in a Maxim Integrated product. No circuit patent licenses are implied. Maxim Integrated reserves the right to change the circuitry and specifications without notice at any time. The parametric values (min and max limits) shown in the *Electrical Characteristics* table are guaranteed. Other parametric values quoted in this data sheet are provided for guidance.