

Features

Regulated Converters

- 2:1 Wide Input Voltage Range
- 1.6kVDC Isolation
- UL Certified
- Efficiency up to 91%
- Six-Sided Continuous Shield
- Available as Power Module (RPM60-G)



RP60-G

60 Watt
2" x 2"
Single Output



UL60950-1 Certified

Description

The RP60-G series DC/DC converters deliver 60W of power in an industry standard 2" x2" package, which also meets military standards for thermal shock and vibration tolerance. Sense pins allow the output voltage at the point of load to be tightly regulated and automatically compensate for any voltage drops that may occur across any connections.

Selection Guide

Part Number	Input Voltage Range [VDC]	Output Voltage [VDC]	Output Current [mA]	Input ⁽¹⁾ Current [mA]	Efficiency ⁽¹⁾ typ. [%]	Max. Capacitive Load ⁽²⁾ [µF]
RP60-243.3SG ^(3,4)	18-36	3.3	14000	2163	89	36000
RP60-2405SG ^(3,4)	18-36	5	12000	2778	90	20400
RP60-2412SG ^(3,4)	18-36	12	5000	2778	90	3550
RP60-2415SG ^(3,4)	18-36	15	4000	2778	90	2300
RP60-483.3SG ^(3,4)	36-75	3.3	14000	1081	89	36000
RP60-4805SG ^(3,4)	36-75	5	12000	1374	91	20400
RP60-4812SG ^(3,4)	36-75	12	5000	1389	90	3550
RP60-4815SG ^(3,4)	36-75	15	4000	1389	90	2300

Notes:

- Note1: Typical value at nominal input voltage and full load.
Note2: Test by minimum Vin and constant resistive load.

Model Numbering



Ordering Examples

- RP60-2405SG = 24V Input, 5V Output, Positive Logic CTRL pin.
RP60-4812SG/N-HC = 48V Input, 12V Output, Negative Logic CTRL pin, Heat-sink fitted

Notes:

- Note3: no suffix for CTRL function with Positive Logic (1=ON, 0=OFF) and trim pin
add suffix "N" for CTRL function with Negative Logic (0=ON, 1=OFF) and trim pin
Note4: add suffix -HC for premounted Heat-sink and clips

Specifications measured at Ta = 25°C, nominal input voltage, full load otherwise noted

BASIC CHARACTERISTICS

Parameter	Condition	Min.	Typ.	Max.
Input Voltage Range	nom. Vin= 24V nom. Vin= 48V	18VDC 36VDC	24VDC 48VDC	36VDC 75VDC
Under Voltage Lockout (UVLO)	Vin = 24V DC-DC ON DC-DC OFF		15VDC	17VDC
	Vin = 48V DC-DC ON DC-DC OFF		32VDC	34VDC
Input Filter				Pi-Type
Input Reflected Ripple Current ⁽⁵⁾	nominal Vin and full load		20mA _{p-p}	
Input Surge Voltage	Vin= 24V, 100ms max. Vin= 48V, 100ms max.			50VDC 100VDC
Start-up time	constant resistive load			Power up Remote ON/OFF 20ms 20ms
Operating Frequency Range		270kHz	300kHz	330kHz
Ripple and Noise	measured by 20MHz bandwidth, with 1µF MLCC on output	3.3V _{out} , 5V _{out} 12V _{out} , 15V _{out}	75mV _{p-p} 100mV _{p-p}	
Remote ON/OFF ⁽⁶⁾	Positive Logic DC-DC ON DC-DC OFF			Open or 3.0V < Vr < 12V Short or 0V < Vr < 1.2V
	Negative Logic DC-DC ON DC-DC OFF			Short or 0V < Vr < 1.2V Open or 3.0V < Vr < 12V
Input current of Remote pin (CTRL)	DC-DC OFF		4mA	
	DC-DC ON	-0.5mA		1.0mA

Notes:

Note5: No minimum loading on the output is required to maintain specified regulation. Operation under no-load condition will not damage these devices.

Note6: The ON/OFF control pin voltage is referenced to the -Vin pin.

RP60-2405SGW

Efficiency vs. Output Current

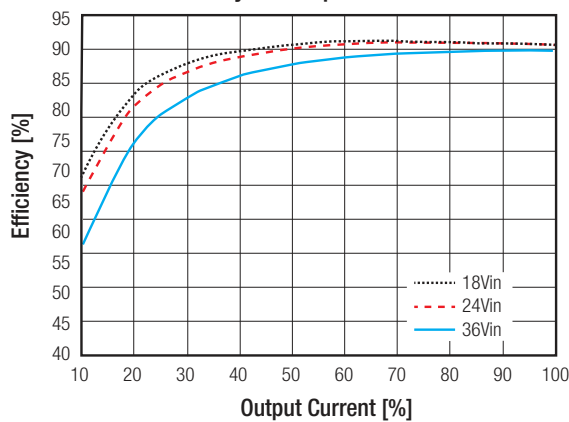

Efficiency vs. Input Voltage

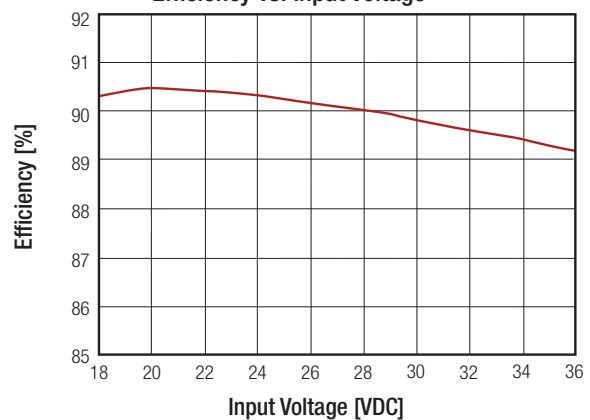

continued on next page

Specifications measured at Ta = 25°C, nominal input voltage, full load otherwise noted

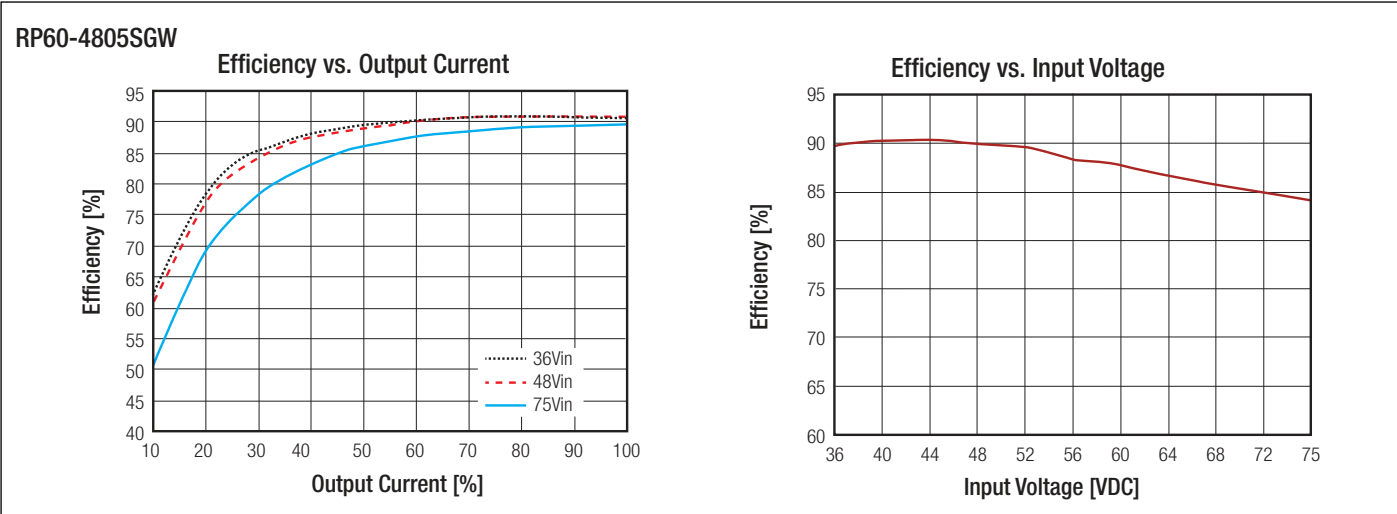

REGULATIONS		
Parameter	Condition	Value
Output Voltage Accuracy	full load and nominal input	±1.0%
Voltage Adjustability ⁽⁷⁾		±10%
Line Voltage Regulation	low line, high line at full load	±0.2%
Load Voltage Regulation ⁽⁸⁾		±0.5%
Transient Response recovery time	25% load step change	250µs typ.

Notes:

Note7: Maximum output deviation is 10% inclusive of remote sense and trim. If remote sense is not being used, the +sense should be connected to its corresponding +OUTPUT and likewise the -sense should be connected to its corresponding -OUTPUT.

Note8: No minimum loading on the output is required to maintain specified regulation. Operation under no-load condition will not damage these devices.

External Output Trimming

Output Voltage Trimming

Single output Powerline converters offer the feature of trimming the output voltage over a certain range around the nominal value by using external trim resistors. No general equation can be given for calculating the trim resistors, but the following trimtables give typical values for choosing these trimming resistors. If voltages between the given trim points are required, extrapolate between the two nearest given values to work out the resistor required or use a variable resistor to set the output voltage. Output can be externally trimmed by using the method shown below.

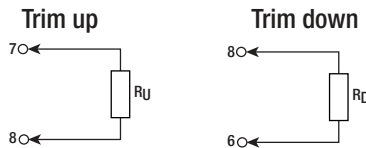

RP60-xx3.3SG

Trim up	1	2	3	4	5	6	7	8	9	10	%
Vout =	3.333	3.366	3.399	3.432	3.465	3.498	3.531	3.564	3.597	3.63	Volts
R _U =	57.93	26.16	15.58	10.28	7.11	4.99	3.48	2.34	1.46	0.75	kOhms
Trim down	1	2	3	4	5	6	7	8	9	10	%
Vout =	3.267	3.234	3.201	3.168	3.135	3.102	3.069	3.036	3.003	2.97	Volts
R _D =	69.47	31.23	18.49	12.12	8.29	5.74	3.92	2.56	1.50	0.65	kOhms

continued on next page

Specifications measured at Ta = 25°C, nominal input voltage, full load otherwise noted

RP60-xx05SG											
Trim up	1	2	3	4	5	6	7	8	9	10	%
Vout =	5.05	5.10	5.15	5.20	5.25	5.30	5.35	5.4	5.45	5.50	Volts
R _v =	36.57	16.58	9.92	6.58	4.59	3.25	2.30	1.59	1.03	0.59	kOhms
Trim down	1	2	3	4	5	6	7	8	9	10	%
Vout =	4.95	4.90	4.85	4.80	4.75	4.70	4.65	4.60	4.55	4.50	Volts
R _b =	45.53	20.61	12.31	8.15	5.66	4.00	2.81	1.92	1.23	0.68	kOhms
RP60-xx12SG											
Trim up	1	2	3	4	5	6	7	8	9	10	%
Vout =	12.12	12.24	12.36	12.48	12.60	12.72	12.84	12.96	13.08	13.20	Volts
R _v =	367.91	165.95	98.64	64.98	44.78	31.32	21.70	14.49	8.88	4.39	kOhms
Trim down	1	2	3	4	5	6	7	8	9	10	%
Vout =	11.88	11.76	11.64	11.52	11.40	11.28	11.16	11.04	10.92	10.8	Volts
R _b =	460.99	207.95	123.60	81.42	56.12	39.25	27.20	18.16	11.13	5.51	kOhms
RP60-xx15SG											
Trim up	1	2	3	4	5	6	7	8	9	10	%
Vout =	15.15	15.3	15.45	15.60	15.75	15.90	16.05	16.20	16.35	16.50	Volts
R _v =	404.18	180.59	106.06	68.80	46.44	31.53	20.88	12.90	6.69	1.72	kOhms
Trim down	1	2	3	4	5	6	7	8	9	10	%
Vout =	14.85	14.70	14.55	14.40	14.25	14.10	13.95	13.80	13.65	13.50	Volts
R _b =	499.82	223.41	131.27	85.20	57.56	39.14	25.97	16.10	8.42	2.282	kOhms

PROTECTIONS		
Parameter	Condition	Value
Short Circuit Protection (SCP)		continuous, automatic recovery
Over Voltage Protection (OVP)	Zener Diode Clamp	3.3Vout 5Vout 12Vout 15Vout
Over Temperature Protection (OTP)		120°C typ.
Over Load Protection (OLP)	% of Iout rated	150% max.
Isolation Voltage	I/P to O/P I/P to O/P to case	1.6kVDC/1 minute 1.6kVDC/1 minute
Isolation Resistance	500VDC	1GΩ min.
Isolation Capacitance		1500pF max.
Notes: Note9: This power module is not internally fused. An input line fuse must always be used.		

Specifications measured at Ta = 25°C, nominal input voltage, full load otherwise noted

ENVIRONMENTAL		
Parameter	Condition	Value
Operating Temperature Range	without derating	-40°C to +50°C
	with derating	-40°C to +110°C
Maximum Case Temperature		+110°C max.
Temperature Coefficient		±0.02%/°C max.
Thermal Impedance	natural convection (20LFM) without Heat-sink	10.5°C/Watt
	natural convection (20LFM) with Heat-sink	8.4°C/Watt
Operating Humidity		5% - 95% RH
Thermal Shock		MIL-STD-810F
Vibration		MIL-STD-810F
MTBF	MIL-HDBK-217F	408.9 x 10 ³ hours
	Bellcore TR-NWT-000332 ⁽¹⁰⁾	1093 x 10 ³ hours

Derating Graph⁽¹¹⁾

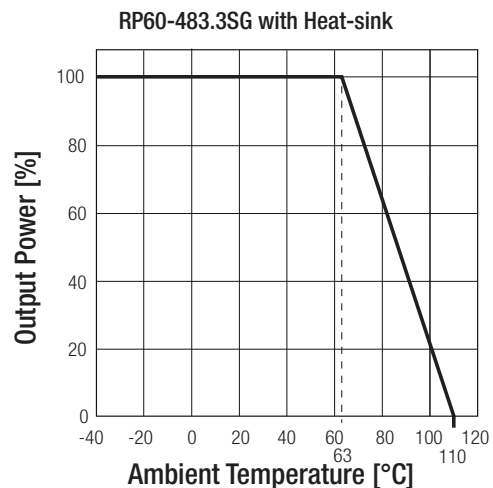
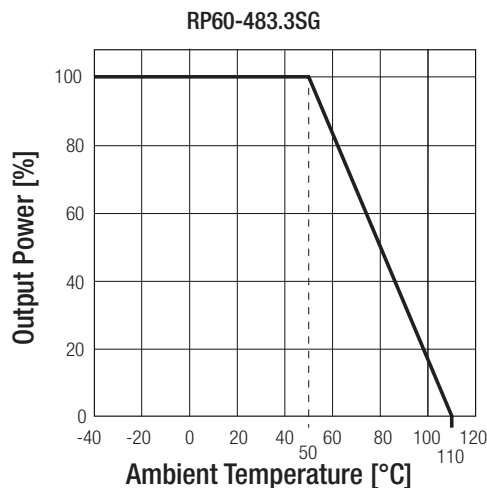

Notes:

Note10: BELLCORE TR-NWT-000332. Case I: 50% Stress, Temperature at 40°C (Ground fixed and controlled environment).

Note11: Derating graphs are valid only for the shown part numbers. If you need detailed derating-information about a part-number not shown here please contact our technical support service at techsupportAT@recom-power.com.

SAFETY AND CERTIFICATIONS

Certificate Type (Safety)	Report / File Number	Standard
UL General Safety	E196683	UL60950-1 1st. Ed.: 2003 C22.2 No. 60950 1st. Ed.: 2003
EMC Compliance	Condition	Standard / Criterion
EMI Standard ⁽¹²⁾	with external filter	EN55022, Class A, Class B
ESD	Air ±8kV and Contact ±6kV	EN61000-4-2, Criteria A
Radiated Immunity	10 V/m	EN61000-4-3, Criteria A
Fast Transient ⁽¹³⁾	±2kV	EN61000-4-4, Criteria A
Surge ⁽¹³⁾	±1kV	EN61000-4-5, Criteria A
Conducted Immunity	10 Vr.m.s	EN61000-4-6, Criteria A

continued on next page

Specifications measured at $T_a = 25^\circ\text{C}$, nominal input voltage, full load otherwise noted

Notes:

Note12: The standard modules meet EMI Class A or Class B with external components, see filter suggestions below.

Note13: An external input filter capacitor is required if the module has to meet EN61000-4-4, EN61000-4-5.

The filter capacitor Recom suggest: Nippon chemi-con KY series, 220 $\mu\text{F}/100\text{V}$

EMI Filtering Class A

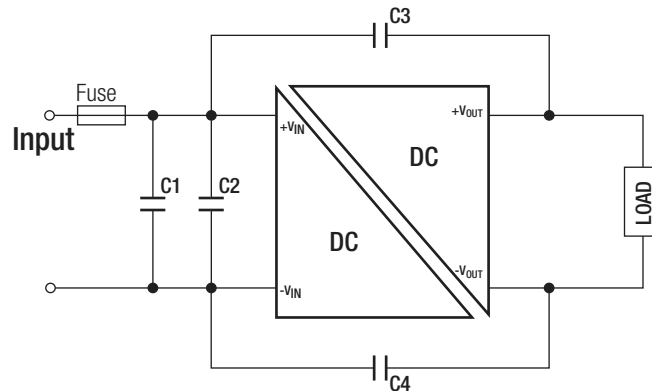

MODEL	C1	C2	C3/C4
RP60-24xxSG	N/A	6.8 $\mu\text{F}/50\text{V}$ 1812 MLCC	1000pF/2kV 1808 MLCC
RP60-48xxSG	2.2 $\mu\text{F}/100\text{V}$ 1812 MLCC	2.2 $\mu\text{F}/100\text{V}$ 1812 MLCC	1000pF/2kV 1808 MLCC

EMI Filtering Class B

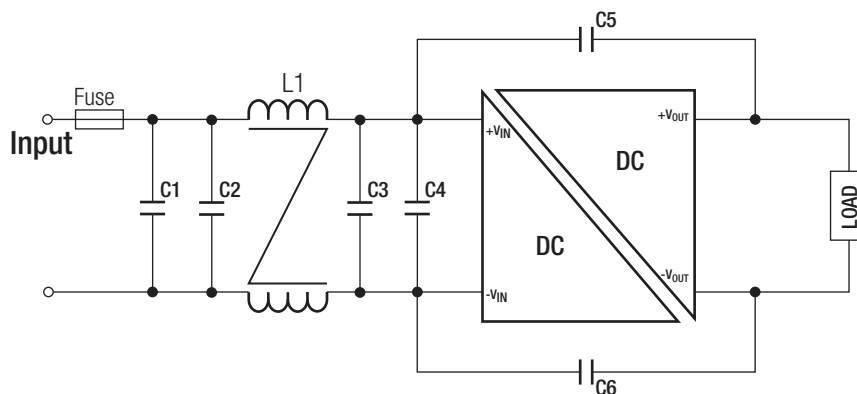

MODEL	C1	C2	C3	C4	C5/C6	L2
RP60-24xxSG	4.7 $\mu\text{F}/50\text{V}$ 1812 MLCC	N/A	4.7 $\mu\text{F}/50\text{V}$ 1812 MLCC	N/A	1000pF/2kV 1808 MLCC	CMC: 450 μH ref.: WE 7448227005 ref.: CMC-05
RP60-48xxSG	2.2 $\mu\text{F}/100\text{V}$ 1812 MLCC	2.2 $\mu\text{F}/100\text{V}$ 1812 MLCC	2.2 $\mu\text{F}/100\text{V}$ 1812 MLCC	N/A	1000pF/2kV 1808 MLCC	CMC: 830 μH ref.: WE 744822301 ref.: CMC-08

Specifications measured at Ta = 25°C, nominal input voltage, full load otherwise noted

DIMENSIONS and PHYSICAL CHARACTERISTICS

Parameter	Type	Value
Material	Case	Nickel coated copper
	Base	FR4 PCB
	Potting	Epoxy (UL94-V0)
Package Dimensions (LxWxH)	without Heat-sink	50.8 x 50.8 x 10.2mm
	with Heat-sink	56.8 x 50.8 x 17.0mm
Package Weight	without Heat-sink	60g
	with Heat-sink	81.06g

Dimensions Drawing (mm)

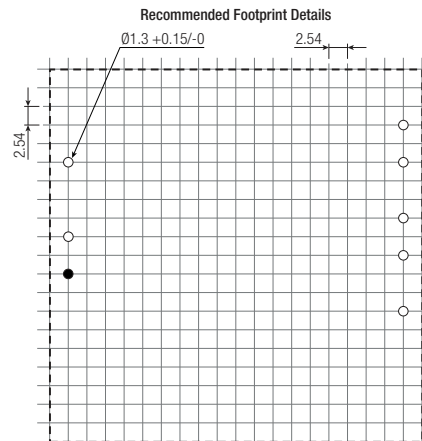
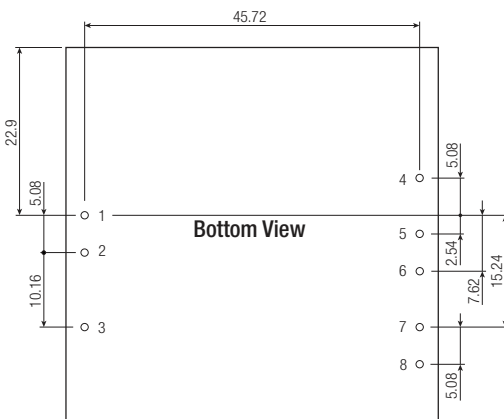
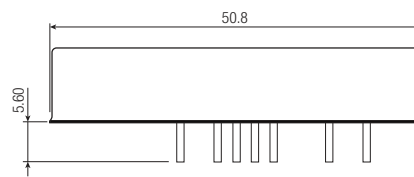
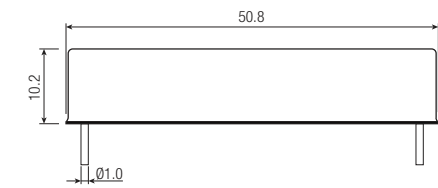
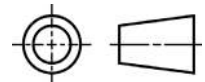

Pin Connections

Pin #	Single
1	+Vin
2	-Vin
3	CTRL
4	-Sense ⁽⁷⁾
5	+Sense ⁽⁷⁾
6	+Vout
7	-Vout
8	Trim

Pin Pitch Tolerance ± 0.25 mm
 Pin Dimension Tolerance ± 0.1 mm
 Tolerance: X.X ± 0.5 mm
 X.XX ± 0.25 mm

Dimension Drawing (mm) with Heat-sink

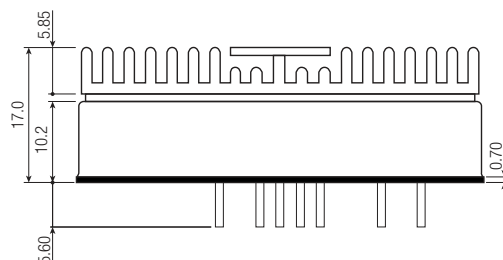
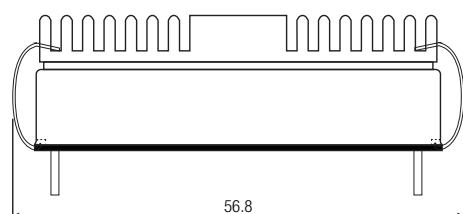
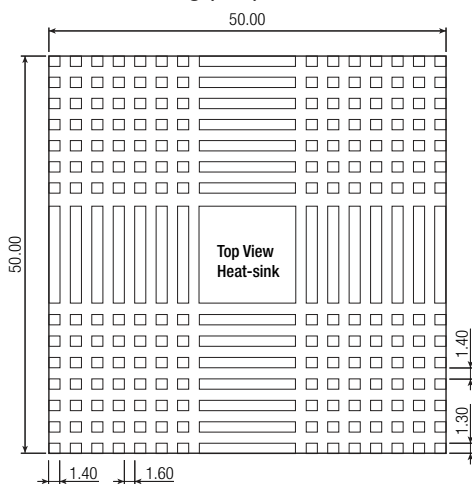

Specifications measured at Ta = 25°C, nominal input voltage, full load otherwise noted

PACKAGING INFORMATION		
Parameter	Type	Value
Packaging Quantity	without Heat-sink	Tube 4pcs.
	with Heat-sink	Tray 12pcs.
Storage Temperature Range		-55°C to +125°C
Storage Humidity		5% - 95% RH

The product information and specifications are subject to change without prior notice. RECOM products are not authorized for use in safety-critical applications (such as life support) without RECOM's explicit written consent. A safety-critical application is defined as an application where a failure of a RECOM product may reasonably be expected to endanger or cause loss of life, inflict bodily harm or damage property. The buyer shall indemnify and hold harmless RECOM, its affiliated companies and its representatives against any damage claims in connection with the unauthorized use of RECOM products in such safety-critical applications.