

FEATURES

- RoHS compliant
- 500Vrms isolation
- Industry-standard footprint
- Compatible with standard networks
- Backward compatible with Sn/Pb soldering systems

DESCRIPTION

The 1605C is a package of unity-turns-ratio isolation transformers. The transformers are designed to have fast rise times with low phase shift and insertion loss to reduce signal distortion. The high shunt impedance of these devices minimises system loading and enables the correct termination conditions to be accurately defined by means of resistors. The devices can be used as network-node isolators in CSMA/CD systems.

SELECTION GUIDE

Order Code	Turns Ratio	Min. Primary Inductance	Max. DC Resistance	Min. ET Constant	Max. Leakage Inductance	Max. Interwinding Capacitance
		μH	Ω	Vμs	μH	pF
Discontinued						
1605C	1:1	26.0	0.2	1.8	0.2	8

ABSOLUTE MAXIMUM RATINGS

Operating free air temperature range	0°C to 70°C
Storage temperature range	-60°C to 125°C
Isolation voltage (flash tested for 1 second)	500Vrms

SOLDERING INFORMATION¹

Peak wave solder temperature, 1.5mm from case	300°C for 10 seconds
Pin finish	Matte Tin

All specifications typical at T_a=25°C.

¹ For further information, please visit www.murata-ps.com/rohs

TECHNICAL NOTES

ISOLATION VOLTAGE

'Hi Pot Test', 'Flash Tested', 'Withstand Voltage', 'Proof Voltage', 'Dielectric Withstand Voltage' & 'Isolation Test Voltage' are all terms that relate to the same thing, a test voltage, applied for a specified time, across a component designed to provide electrical isolation, to verify the integrity of that isolation.

All products in this series are 100% production tested at their stated isolation voltage.

A question commonly asked is, "What is the continuous voltage that can be applied across the part in normal operation?"

For a part holding no specific agency approvals both input and output should normally be maintained within SELV limits i.e. less than 42.4V peak, or 60VDC. The isolation test voltage represents a measure of immunity to transient voltages and the part should never be used as an element of a safety isolation system. The part could be expected to function correctly with several hundred volts offset applied continuously across the isolation barrier; but then the circuitry on both sides of the barrier must be regarded as operating at an unsafe voltage and further isolation/insulation systems must form a barrier between these circuits and any user-accessible circuitry according to safety standard requirements.

REPEATED HIGH-VOLTAGE ISOLATION TESTING

It is well known that repeated high-voltage isolation testing of a barrier component can actually degrade isolation capability, to a lesser or greater degree depending on materials, construction and environment. This series has toroidal isolation transformers, with no additional insulation between primary and secondary windings of enameled wire. While parts can be expected to withstand several times the stated test voltage, the isolation capability does depend on the wire insulation. Any material, including this enamel (typically polyurethane) is susceptible to eventual chemical degradation when subject to very high applied voltages thus implying that the number of tests should be strictly limited. We therefore strongly advise against repeated high voltage isolation testing, but if it is absolutely required, that the voltage be reduced by 20% from specified test voltage.

This consideration equally applies to agency recognized parts rated for better than functional isolation where the wire enamel insulation is always supplemented by a further insulation system of physical spacing or barriers.



For full details go to www.murata-ps.com/rohs

PACKAGE SPECIFICATIONS

MECHANICAL DIMENSIONS

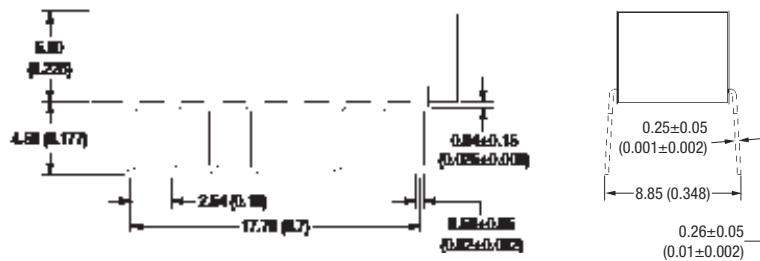
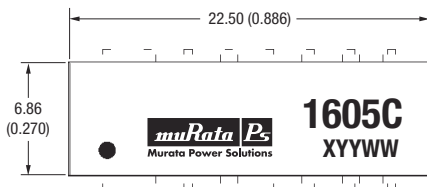

All dimensions in mm (inches) ± 0.25 (0.001) unless otherwise stated.
 Package weight: 1.7g Typ.

PIN CONNECTIONS

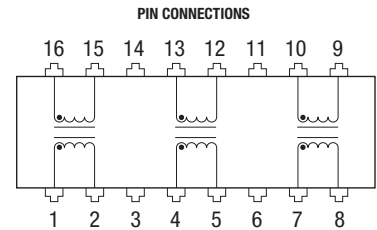

TUBE DIMENSIONS

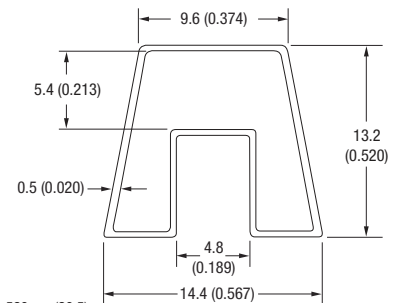

Tube length: 520mm (20.5)
 All dimensions in mm (inches) ± 0.25 (0.001) unless otherwise stated.
 Package quantity: 20