

NOTES:

1. MATERIAL: LCP, GLASS FILLED, UL94V-0, BLACK.
CONTACTS: COPPER ALLOY
2. FINISH: SELECT GOLD: 30 MI MIN.
SELECT TIN: 100 MI MIN.
BOTH OVER NICKEL.
3. PRODUCT SPECIFICATION: PS-45424-001.
4. PACKAGING SPECIFICATION: PK-45483-001.

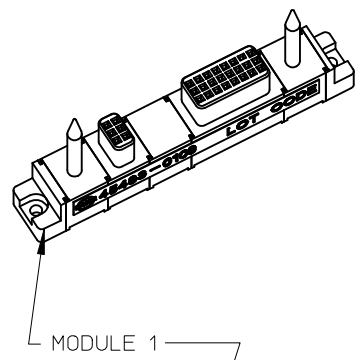
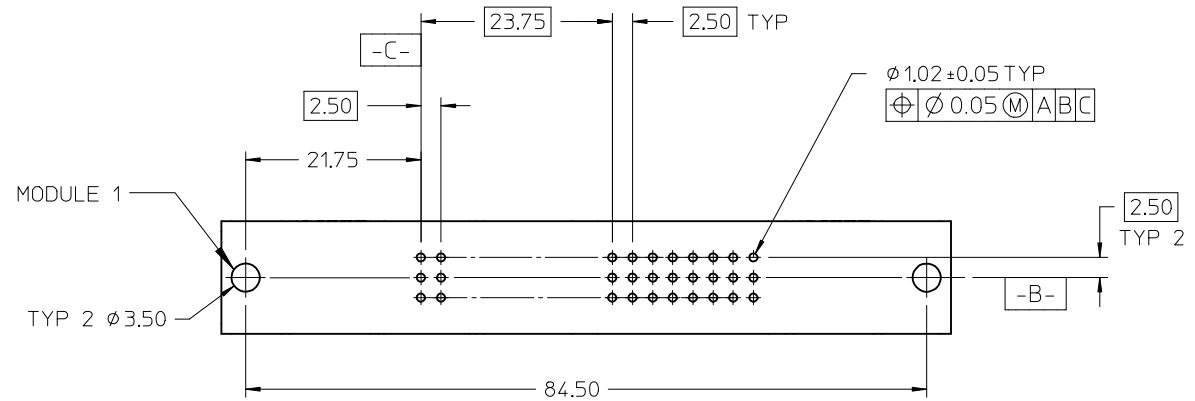

PCB LAYOUT: COMPONENT SIDE
PCB THICKNESS: .125/3.18
PCB TOLERANCE: ±.002/0.05

EC NO: UCP2006-0531 DRWN: ADRA TNL2005/09/13 CHKD: 2005/09/15 APPR: APATEL 2005/09/15	DESCRIPTION
	REV

QUALITY SYMBOLS	GENERAL TOLERANCES (UNLESS SPECIFIED)	
	mm	INCH
	4 PLACES	± --- ± ---
	3 PLACES	± --- ± .010
	2 PLACES	± 0.25 ± .015
	1 PLACE	± 0.38 ± ---
	ANGULAR ±1/2°	
	DRAFT WHERE APPLICABLE	
	MUST REMAIN WITHIN DIMENSIONS	

SCALE	DESIGN UNITS
1:1	METRIC
DIMENSION STYLE	
IN/MM	
DRAWN BY	DATE
SCHAFFER	2004/04/01
CHECKED BY	DATE
SAMIEC	2004/04/01
APPROVED BY	DATE
MARGULIS	2004/04/01

THIRD ANGLE PROJECTION	REVISE ON CAD ONLY	
TITLE	POWER DOCK ASSEMBLY SOCKET VERTICAL SOLDER TAIL	
MOLEX INCORPORATED		
MATERIAL NO.	DOCUMENT NO.	SHEET NO.
45483-0109	SD-45483-109	1 OF 1
THIS DRAWING CONTAINS INFORMATION THAT IS PROPRIETARY TO MOLEX INCORPORATED AND SHOULD NOT BE USED WITHOUT WRITTEN PERMISSION		