

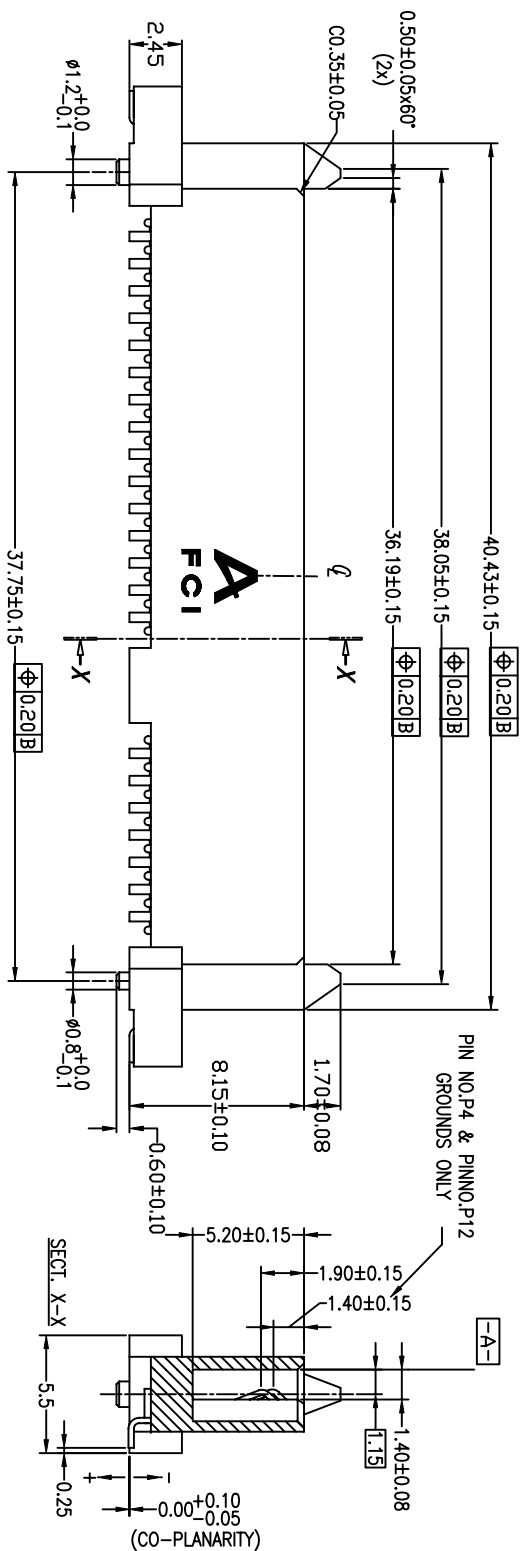

PRODUCT NO.
SEE TABLE

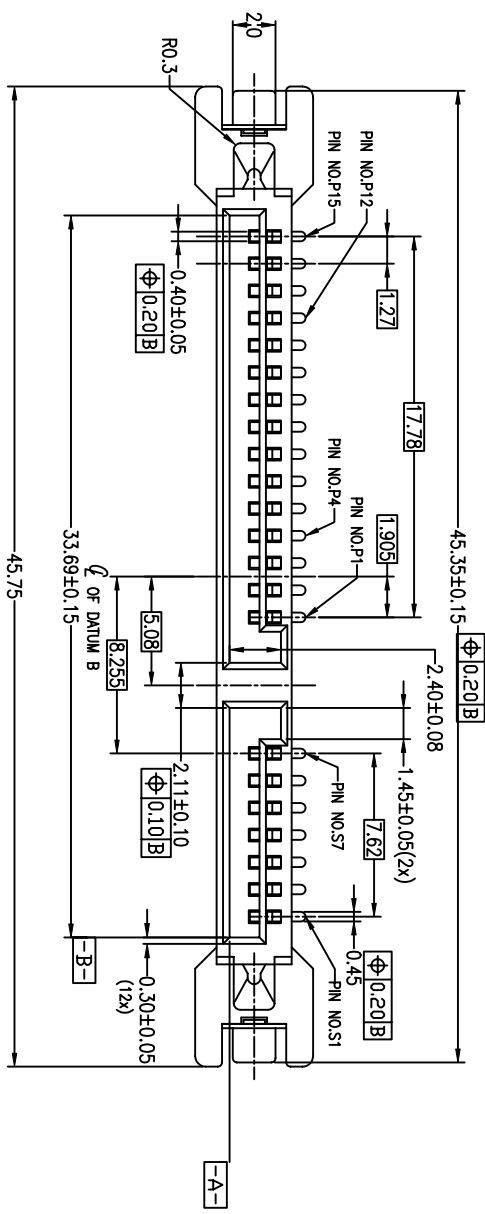

CONFIDENTIAL

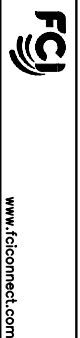

CUSTOMER COPY
title: S-ATA COMBO RECE.
SMT VERTICAL TYPE ASS'Y

litr	ecn no	dr	dtte	linear	angles	engr	chr	appd	scale	product family	code
A	S03-0090	GILL	06/26/03	.XX ± 0.25		GL LOO	6/26/03		MM	SATA	TWN
B	S03-0162	GILL	10/03/03	.XXX ± 0.15	0° ± 2°	GL LOO	6/26/03		NA	SATA	sheet
C	S04-0084	GILL	04/27/04			JOEY NG	6/27/03			59337	1 of
D	T07-1110	S.LIN	07/04/07			GL LOO	6/26/03				
E	T08-1035	S.LIN	03/06/08			GL LOO	6/26/03				

mot'l. code	tolerances unless otherwise specified	projection	title	product family	code
	X ± 0.38	MM	S-ATA COMBO RECE. SMT VERTICAL TYPE ASS'Y	SATA	TWN

1 2 3 4

