

AS1927

Nanopower μ P Supervisory Circuits with Manual Reset and Watchdog Timer

1 General Description

The AS1927 microprocessor supervisory circuits were designed to generate a reset when the monitored supply voltage falls below a factory-trimmed threshold. The reset remains asserted for a minimum timeout period after the supply voltage stabilizes.

Guaranteed to be in the correct state for Vcc higher than +1.0V, these devices are ideal for portable and battery-powered systems with strict monitoring requirements.

The devices feature factory-trimmed thresholds to monitor a supply voltage between 1.575V and 4.625V.

The devices are available with the reset output types listed in [Table 1](#).

Table 1. Standard Products

Model	Reset Output Type
AS1927L	Active-Low Push/Pull
AS1927H	Active-High Push/Pull
AS1927D	Active-Low Open-Drain

The AS1927 include a manual-reset input for systems that never fully power down the microprocessor.

Additionally, these devices feature a watchdog timer to ensure that the processor is operating within proper code boundaries. A watchdog disable feature allows to turn off the watchdog if not required or unwanted, as in boot up conditions of microcontrollers.

The AS1927 are available in a 6-pin TDFN (2x2mm) package.

2 Key Features

- 170nA Ultra-Low Supply Current
- Vcc Supervisory Range: +1.575V to +4.625V (for further information see [Ordering Information on page 10](#))
- Guaranteed Reset Valid Down to Vcc = +1.0V
- Six Minimum Reset Timeout Period Options from: 10ms to 1.2s
- Manual Reset Input
- Watchdog Timeout Period: 1.5s or 1.5min
- Three Reset Output Types
 - Active-Low Push/Pull (AS1927L)
 - Active-High Push/Pull (AS1927H)
 - Active-Low Open-Drain (AS1927D)
- Immune to Fast Negative Vcc Transients
- External Components Not Required
- Operating Temperature Range: -40 to +85°C
- 6-pin TDFN (2x2mm) Package

3 Applications

The devices are ideal for low-power portable and battery-powered systems, embedded controllers, intelligent instruments, automotive systems, and critical CPU monitoring applications.

Figure 1. AS1927 - Typical Application Diagram

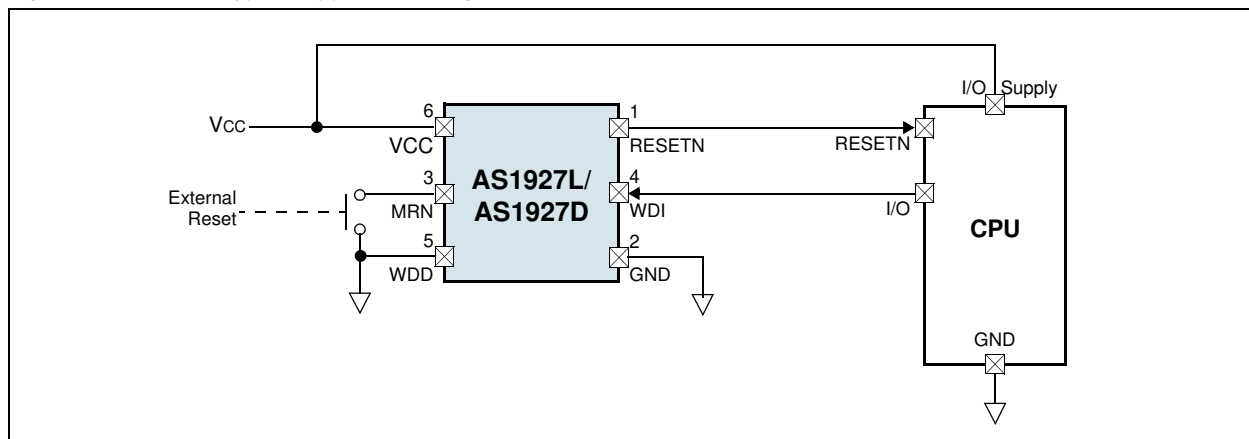

4 Pinout

Pin Assignments

Figure 2. Pin Assignments (Top View)

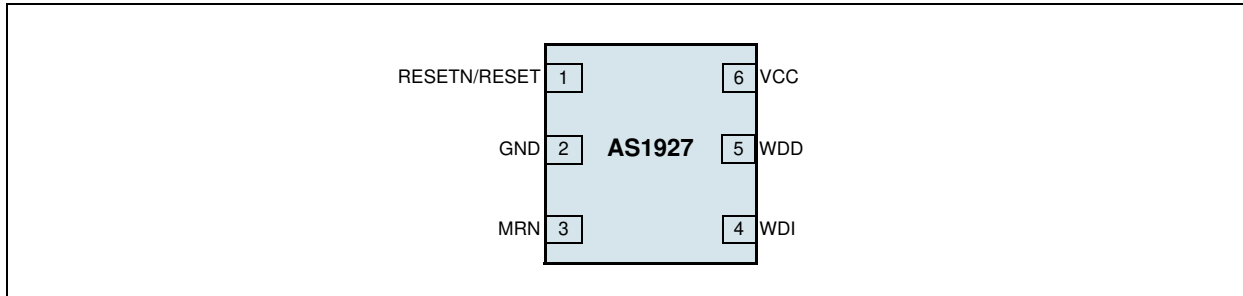

Pin Descriptions

Table 2. Pin Descriptions

Pin Number	Pin Name	Description
1	RESETN	Active-Low Reset Output (AS1927L, AS1927D). The RESETN signal toggles from high to low when VCC crosses the threshold (falling), or MRN is pulled low, or the watchdog triggers a reset. This output signal remains low for the reset timeout period (see t_{RP} on page 4) after the supervised voltage exceeds its reset threshold, or MRN goes low to high.
	RESET	Active-High Reset Output (AS1927H). The RESET signal toggles from low to high when VCC crosses the threshold (falling), or MRN is pulled low, or the watchdog triggers a reset. This output signal remains high for the reset timeout period (see t_{RP} on page 4) after the supervised voltage exceeds its reset threshold, or MRN goes low to high.
2	GND	Ground
3	MRN	Active-Low Manual Reset Input. Pulling this pin low asserts a reset. This pin is connected to the internal 20kΩ pullup to VCC. This reset remains active as long as MRN is low and for the reset timeout period (see t_{RP} on page 4) after MRN goes high. Note: If the manual reset feature is not used, this pin should be unconnected or connected to VCC.
4	WDI	Watchdog Input. If WDI remains high or low for longer than the watchdog timeout period (see t_{WD} on page 5), the internal watchdog timer period expires and a reset is triggered for the reset timeout period (see t_{RP} on page 4). The internal watchdog timer clears whenever a reset is asserted or when WDI senses a rising or falling edge.
5	WDD	Watchdog Disable. This pin allows to turn on or off the watchdog feature. Pin to GND: Watchdog enabled. Pin to VCC: Watchdog disabled.
6	VCC	Supervised Voltage Input. This pin serves as the supervised supply voltage input.

5 Absolute Maximum Ratings

Stresses beyond those listed in [Table 3](#) may cause permanent damage to the device. These are stress ratings only, and functional operation of the device at these or any other conditions beyond those indicated in [Electrical Characteristics on page 4](#) is not implied. Exposure to absolute maximum rating conditions for extended periods may affect device reliability.

Table 3. Absolute Maximum Ratings

Parameter	Min	Max	Units	Comments
VCC to GND	-0.3	+7.0	V	
Open-Drain RESETN	-0.3	+7.0	V	
Push/Pull RESET, RESETN	-0.3	V _{CC} + 0.3	V	
MRN, WDI to GND	-0.3	V _{CC} + 0.3	V	
Input and Output Current (all pins)		20	mA	
ESD		1	kV	HBM MIL-Std. 883E 3015.7 methods
Continuous Power Dissipation (T _{AMB} = +70°C)		696	mW	Derate 8.7mW/°C above +70°C
Operating Temperature Range	-40	+85	°C	
Junction Temperature		+150	°C	
Storage Temperature Range	-65	+150	°C	
Package Body Temperature		+260	°C	The reflow peak soldering temperature (body temperature) specified is in accordance with IPC/JEDEC J-STD-020D "Moisture/Reflow Sensitivity Classification for Non-Hermetic Solid State Surface Mount Devices". The lead finish for Pb-free leaded packages is matte tin (100% Sn).

6 Electrical Characteristics

$V_{CC} = +1.2V$ to $+5.5V$; $T_{AMB} = -40^{\circ}C$ to $+85^{\circ}C$. Typ values are @ $T_{AMB} = +25^{\circ}C$ (unless otherwise specified).

Table 4. Electrical Characteristics

Symbol	Parameter ¹	Conditions	Min	Typ	Max	Units	
V _{CC}	Operating Voltage Range	T _{AMB} = 0 to +85°C	1.0		5.5	V	
		T _{AMB} = -40 to +85°C	1.2		5.5		
I _{CC}	V _{CC} Supply Current	No Load, V _{CC} = +5.0V		210	400	nA	
		No Load, V _{CC} = +3.3V		190	380		
		No Load, V _{CC} = +1.8V		170	370		
V _{TH}	V _{CC} Reset Threshold	V _{CC} falling	-2		2	%	
	Reset Threshold Temperature Coefficient ²				170	ppm/ _{°C}	
	Reset Threshold Hysteresis			0.5		%/ V _{TH}	
t _{RD}	V _{CC} to Reset Output Delay	V _{CC} = (V _{TH} + 100mV) to (V _{TH} - 100mV) @ 10mV/μs		40		μs	
t _{RP}	Reset Timeout Period	V _{CC} = (V _{TH} -2%) to (V _{TH} + 150mV)	D1	10	15	25	ms
			D2	40	60	80	
			D3	150	225	300	
			D4	300	450	600	
			D5	600	900	1200	
			D6	1200	1800	2400	
V _{OL}	RESETN Output Low (Push/Pull or Open-Drain)	V _{CC} ≥ 1.0V, I _{SINK} = 50μA, Reset Asserted, T _{AMB} = 0 to +85°C			0.3	V	
		V _{CC} ≥ 1.2V, I _{SINK} = 100μA, Reset Asserted			0.3		
		V _{CC} ≥ 2.12V, I _{SINK} = 1.2mA, Reset Asserted			0.3		
		V _{CC} ≥ 3.3V, I _{SINK} = 3.2mA, Reset Asserted			0.3		
V _{OH}	RESETN Output High (Push/Pull Only)	V _{CC} ≥ 1.71V, I _{SOURCE} = 200μA, Reset Not Asserted	0.8 x V _{CC}			V	
		V _{CC} ≥ 2.38V, I _{SOURCE} = 500μA, Reset Not Asserted	0.8 x V _{CC}				
		V _{CC} ≥ 3.3V, I _{SOURCE} = 800μA, Reset Not Asserted	0.8 x V _{CC}				
I _{LKG}	Open-Drain RESETN Output Leakage Current	RESETN Not Asserted			25	nA	
V _{OH}	RESET Output High (Push/Pull Only)	V _{CC} ≥ 1.0V, I _{SOURCE} = 10μA, Reset Asserted, T _{AMB} = 0 to +85°C	0.8 x V _{CC}			V	
		V _{CC} ≥ 1.50V, I _{SOURCE} = 200μA, Reset Asserted	0.8 x V _{CC}				
		V _{CC} ≥ 2.12V, I _{SOURCE} = 500μA, Reset Asserted	0.8 x V _{CC}				
		V _{CC} ≥ 3.3V, I _{SOURCE} = 800μA, Reset Asserted	0.8 x V _{CC}				

Table 4. Electrical Characteristics (Continued)

Symbol	Parameter ¹	Conditions	Min	Typ	Max	Units
V _{OL}	RESET Output Low (Push/Pull Only)	V _{CC} ≥ 1.71V, I _{SINK} = 500μA, Reset Asserted			0.3	V
		V _{CC} ≥ 2.38V, I _{SINK} = 1.2mA, Reset Asserted			0.3	
		V _{CC} ≥ 3.3V, I _{SINK} = 3.2mA, Reset Asserted			0.3	
Manual Reset Input						
V _{IH}	MRN Input voltage		0.7 x V _{CC}			V
V _{IL}				0.3 x V _{CC}		
	MRN Minimum Input Pulse		1			μs
	MRN Transient Rejection			200		ns
	MRN to Reset Delay			250		ns
	MRN Pullup Resistance			20		kΩ
Watchdog Input						
V _{IH}	WDI Input Voltage ²		0.7 x V _{CC}			V
V _{IL}					0.3 x V _{CC}	
V _{IHE}	WDD Input Voltage ²		0.7 x V _{CC}			V
V _{ILE}					0.3 x V _{CC}	
t _{WD}	Watchdog Timeout Period	S		3.3		s
		M		6		
		L		12		
		X		24		
t _{WDI}	WDI Pulse Width ²		150			ns
I _{WDI}	WDI Input Current	WDI = V _{CC} , Time Average			20	nA

1. Over-temperature limits are guaranteed by design and not production tested. Devices tested at +25°C.

2. Guaranteed by design and not production tested.

Note: All limits are guaranteed. The parameters with min and max values are guaranteed with production tests or SQC (Statistical Quality Control) methods.

7 Detailed Description

The AS1927 supervisory circuits were designed to generate a reset when the monitored supply voltage falls below its factory-trimmed trip threshold (see [Threshold Voltage Suffix Guide \(x\) on page 10](#)), and to maintain the reset for a minimum timeout period (see t_{RP} on [page 4](#)) after the supply has stabilized.

The integrated watchdog timer (see [Watchdog Input on page 7](#)) helps mitigate against bad programming code or clock signals, and/or poor peripheral response.

The active-low manual reset input (see [Manual Reset Input on page 7](#)) allows for an externally activated system reset.

RESET/RESETN

Whenever the monitored supply voltage falls below its reset threshold, the RESET output asserts high or the RESETN output asserts low. Once the monitored voltage has stabilized, an internal timer keeps the reset asserted for the reset timeout period (t_{RP}). After the t_{RP} period, the RESET/RESETN output returns to its original state (see [Figure 4](#)).

Figure 3. Functional Diagram of Vcc Supervisory Application

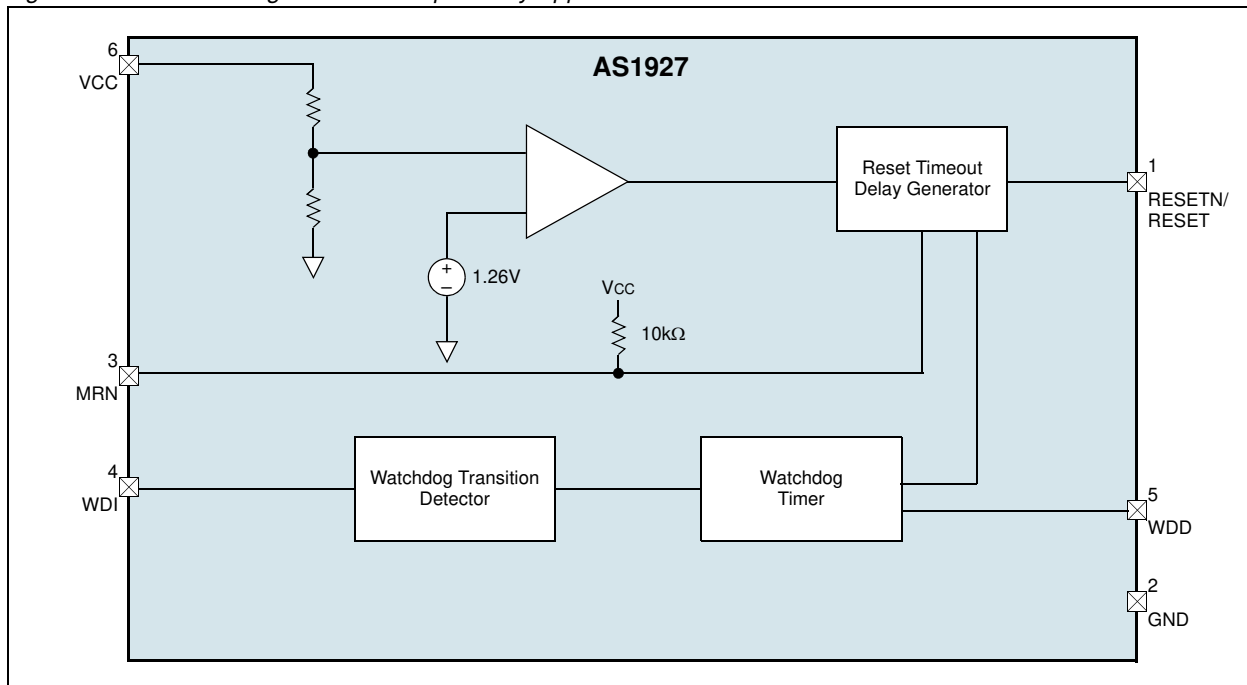
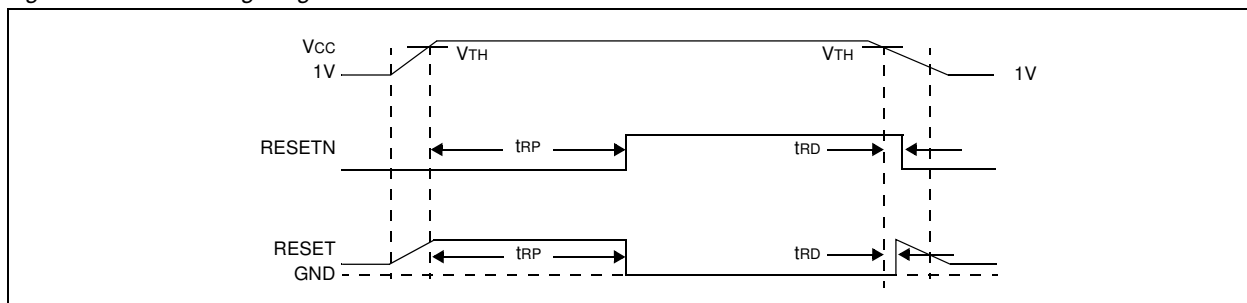

Figure 4. Reset Timing Diagram



Watchdog Input

The integrated watchdog feature can be used to monitor processor activity via pin WDI, and can detect pulses as short as 150ns. The watchdog requires that the processor toggle the watchdog logic input at regular intervals, within a specified minimum watchdog timeout period (1.5s or 1.5min). A reset is asserted for the reset timeout period. As long as reset is asserted, the timer remains cleared and is not incremented. When reset is deasserted, the watchdog timer starts counting (Figure 5).

Note: The watchdog timer can be cleared with a reset pulse or by toggling WDI.

Figure 5. Watchdog Timing Relationship

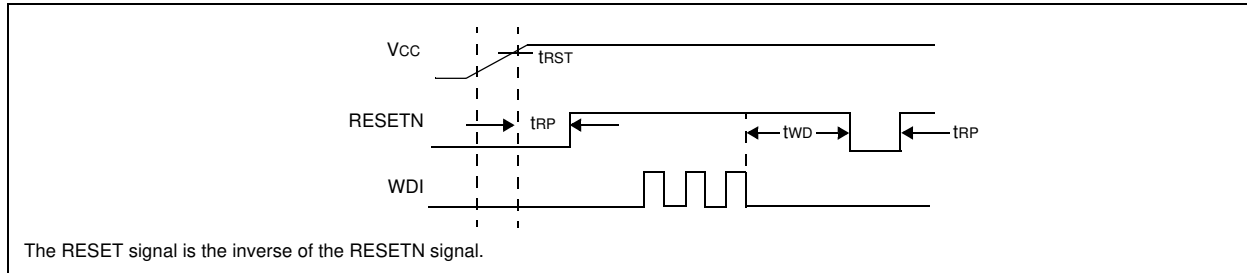

Watchdog Enable Input

The active-low pin WDD is used to enable or disable the watchdog timer. As long as this pin is pulled to Vcc the watchdog timer stops and is reset. When WDD is pulled to GND the watchdog works as normal. This feature can be used if the watchdog is not in use or during the boot phase of the μ C to prevent unintended resets.

Manual Reset Input

The active-low pin MRN is used to force a manual reset. This input can be driven by CMOS logic levels or with open-drain collector outputs.

Pulling MRN low asserts a reset which will remain asserted as long as MRN is kept low, and for the timeout period (see t_{RP} on page 4) after MRN goes high. The manual reset circuitry has an internal 20k Ω pullup resistor, thus it can be left open if not used.

To create a manual-reset circuit, connect a normally open momentary switch from pin MRN to GND (see Figure 1 on page 1); external debounce circuitry is not required in this configuration.

If MRN is driven via long cables or the device is used in a noisy environment, a 0.1 μ F capacitor between pin MRN and GND will provide additional noise immunity.

8 Application Information

Interfacing to Bi-Directional CPU Reset Pins

Since the reset output of the AS1927D is open drain, this device interfaces easily with processors that have bi-directional reset pins. Connecting the processor reset output directly to the AS1927D RESETN pin with a single pullup resistor (see Figure 6) allows the AS1927D to assert a reset.

Figure 6. AS1927D RESETN-to-CPU Bi-Directional Reset Pin

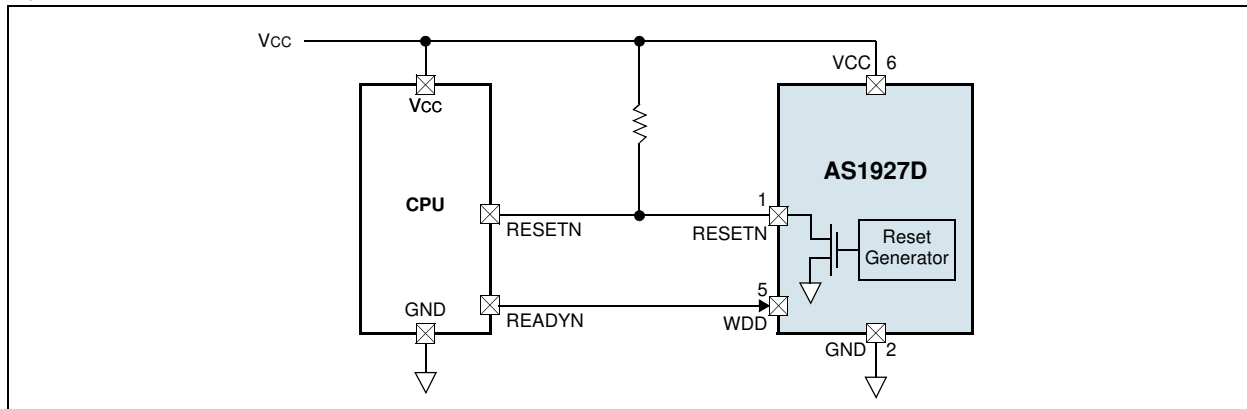

Fast Negative-Going Transients

Fast, negative-going Vcc transients normally do not require the CPU to be shutdown. The AS1927 are virtually immune to such transients. Resets are issued to the CPU during power-up, powerdown, and brownout conditions.

Note: Vcc transients that go 100mV below the reset threshold and last $\leq 55\mu\text{s}$ typically will not assert a reset pulse.

Valid Reset to Vcc = 0

The AS1927 are guaranteed to operate properly down to Vcc = 1V.

For AS1927L and AS1927H applications requiring valid reset levels down to Vcc = 0, a pulldown resistor to active-low outputs and a pullup resistor to active-high outputs will ensure that the reset line is valid during the interval where the reset output can no longer sink or source current.

9 Package Drawings and Markings

The devices are available in a 6-pin TDFN (2x2mm) package.

Figure 7. 6-pin TDFN (2x2mm) Package

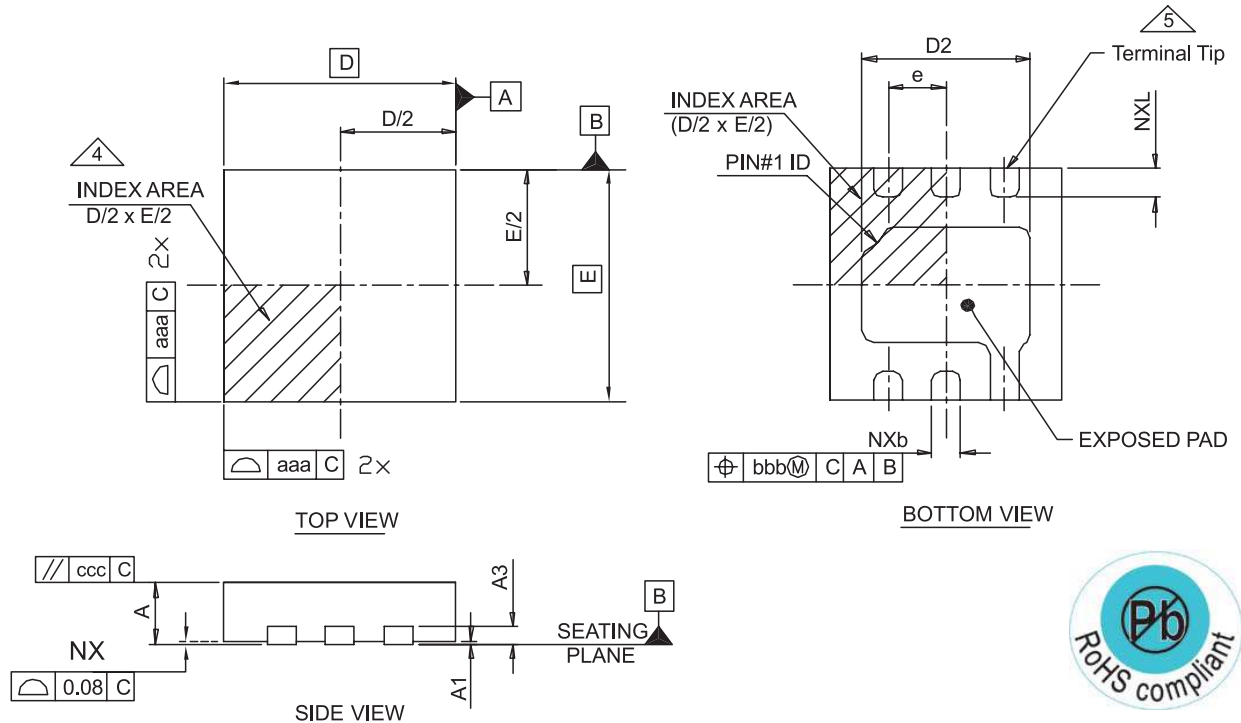

Symbol	Min	Typ	Max	Notes	Symbol	Min	Typ	Max	Notes
A	0.51	0.55	0.60	1, 2	D	1.95	2.00	2.05	
A1	0.00	0.02	0.05	1, 2	E	1.95	2.00	2.05	
A3		0.15 ref		1, 2	D2	1.30	1.45	1.55	
aaa		0.15			E2	0.85	1.00	1.10	
bbb		0.10			L	0.15	0.25	0.35	
ccc		0.10			b	0.20	0.25	0.32	
N		6		3	e		0.5		
ND		3		5					

Notes:

- All dimensions are in millimeters; angles in degrees.
- N is the total number of terminals.
- The terminal #1 identifier and terminal numbering convention shall conform to *JEDEC 95-1, SPP-012*. Details of terminal #1 identifier are optional, but must be located within the zone indicated. The terminal #1 identifier may be either a mold or marked feature.
- ND refers to the maximum number of terminals on side D.
- Depopulation is possible in a symmetrical fashion.
- Figure 7 is shown for illustration only.

10 Ordering Information

The devices are available as the standard products shown in [Table 5](#).

Table 5. Ordering Information

Ordering Code	Marking	Description	Delivery Form	Package
AS1927L-BTDT-33s	AY	Low Power Supervisory Circuit with 1.9V threshold, 225ms Timeout and 3.3s Watchdog	Tape and Reel	6-pin TDFN (2x2mm)
AS1927L-BTDT-xyz*	—	Low Power Supervisory Circuit with x threshold, y Timeout and z Watchdog	Tape and Reel	6-pin TDFN (2x2mm)

*) on request

Note: All products are RoHS compliant.

Buy our products or get free samples online at ICdirect: <http://www.austriamicrosystems.com/ICdirect>

These devices are available in factory-set Vcc thresholds from 1.575V to 4.625V in ~100mV increments. Choose the desired reset threshold suffix from [Table 6](#) and insert it instead of “x” in the part number.

Factory-programmed reset timeout periods are also available. Insert the code corresponding to the desired nominal reset timeout period from [Table 7](#) instead of “y” in the part number.

For the desired watchdog timeout period insert the suffix from [Table 8](#) as “z” into the ordering code.

All devices are available in tape-and-reel only.

Table 6. Threshold Voltage Suffix Guide (x)

Suffix	Min	Typ	Max	Suffix	Min	Typ	Max	Suffix	Min	Typ	Max
a	4.509	4.625	4.741	l		3.500		w		2.400	
b	4.338	4.500	4.613	m		3.400		x		2.313	
c	4.266	4.375	4.484	n		3.300		y		2.235	
d	4.193	4.300	4.408	o		3.200		z		2.188	
e	4.095	4.200	4.305	p		3.075		1		2.100	
f	3.998	4.100	4.203	q		3.000		2		2.000	
g		4.000		r		2.925		3		1.900	
h		3.900		s		2.800		4		1.800	
i		3.800		t		2.700		5		1.665	
j		3.700		u		2.625		6		1.575	
k		3.600		v		2.500					

Table 7. Timeout Option Suffix Guide (y)

Suffix	Reset Timeout Periods			UNITS
	Min	Typ	Max	
1	10	15	25	ms
2	40	60	80	
3	150	225	300	
4	300	450	600	
5	600	900	1200	
6	1200	1800	2400	

Table 8. Watchdog Timeout (z)

Suffix	Watchdog Timeout Periods			UNITS
	Min	Typ	Max	
s		3.3		s
m		6		
l		12		
x		24		

Copyrights

Copyright © 1997-2010, austriamicrosystems AG, Tobelbaderstrasse 30, 8141 Unterpremstaetten, Austria-Europe. Trademarks Registered ®. All rights reserved. The material herein may not be reproduced, adapted, merged, translated, stored, or used without the prior written consent of the copyright owner.

All products and companies mentioned are trademarks or registered trademarks of their respective companies.

Disclaimer

Devices sold by austriamicrosystems AG are covered by the warranty and patent indemnification provisions appearing in its Term of Sale. austriamicrosystems AG makes no warranty, express, statutory, implied, or by description regarding the information set forth herein or regarding the freedom of the described devices from patent infringement. austriamicrosystems AG reserves the right to change specifications and prices at any time and without notice. Therefore, prior to designing this product into a system, it is necessary to check with austriamicrosystems AG for current information. This product is intended for use in normal commercial applications. Applications requiring extended temperature range, unusual environmental requirements, or high reliability applications, such as military, medical life-support or life-sustaining equipment are specifically not recommended without additional processing by austriamicrosystems AG for each application. For shipments of less than 100 parts the manufacturing flow might show deviations from the standard production flow, such as test flow or test location.

The information furnished here by austriamicrosystems AG is believed to be correct and accurate. However, austriamicrosystems AG shall not be liable to recipient or any third party for any damages, including but not limited to personal injury, property damage, loss of profits, loss of use, interruption of business or indirect, special, incidental or consequential damages, of any kind, in connection with or arising out of the furnishing, performance or use of the technical data herein. No obligation or liability to recipient or any third party shall arise or flow out of austriamicrosystems AG rendering of technical or other services.



Contact Information

Headquarters

austriamicrosystems AG
Tobelbaderstrasse 30
A-8141 Unterpremstaetten, Austria

Tel: +43 (0) 3136 500 0
Fax: +43 (0) 3136 525 01

For Sales Offices, Distributors and Representatives, please visit:

<http://www.austriamicrosystems.com/contact>