

PART NUMBER	REVISION	DESCRIPTION	FEED TYPE
2151742-1	H	FINE CRIMP HEIGHT ADJUST	MECHANICAL
2151742-2	H	FINE CRIMP HEIGHT ADJUST	PNEUMATIC
7-2151742-1	H	MECHANICAL AND CRIMP TOOLING KIT	MECHANICAL
7-2151742-2	H	PNEUMATIC AND CRIMP TOOLING KIT	PNEUMATIC
7-2151742-7	D	CRIMP TOOLING KIT	-

ATLANTIC VERSION TERMINATOR INTERFACE ADAPTER

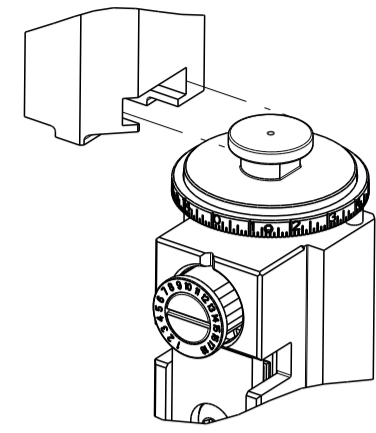

APPLICATOR DATA		
CRIMP	SIZE	TYPE
WIRE	2.29 mm [.090]	F
INSUL	4.06 mm [.160]	F

APPLICATOR INSTRUCTIONS  
408-35042

TERMINAL DATA: TE TERMINAL		TE CRIMP SPECIFICATION	
TERMINAL NAME: RECEPTACLE CONTACT NEXT GENERATION SOFET SHELL			
WIRE STRIP LENGTH		INSULATION DIAMETER RANGE	
4.20-4.80 mm [.165-.189 IN]		Ø3.40-3.70 mm [.134-.146 IN]	
TERMINAL APPLICATION SPECIFICATION	114-106118		
TERMINALS APPLIED			
TE TERMINAL	TE TERMINAL	TE TERMINAL	TE TERMINAL
1971781-1	1971781-2	1971782-1	1971782-2

WIRE SIZE	CRIMP HEIGHT mm [INCH]	CRIMP HEIGHT REFERENCE SETTING
14 AWG OR 2.10mm2	1.63 +/- 0.05 [.064 +/- .002]	9.0



- RECOMMENDED SPARE PARTS
- REFER TO SUPPLIED INSTRUCTION SHEET FOR CLEANING, LUBRICATION AND STORAGE OF APPLICATOR.
- APPLY PART NUMBER 2-23419-6 LOCTITE TO THREADS OF ITEM 242.
- CRIMP HEIGHT REFERENCE SETTING WAS THE SETTING USED WHEN THE APPLICATOR WAS QUALIFIED AT THE FACTORY. ADJUSTMENT MAY BE NECESSARY WHEN RUNNING APPLICATOR IN THE FIELD.
- TERMINAL 1971781 REVISION 11. TERMINAL 1971782 REVISION 10.
- 6. UNLESS SPECIFIED OTHERWISE TORQUE VALUES SHALL BE USED PER DOCUMENT, 101-35000.
- TERMINAL LUBRICANT IS RECOMMENDED.

**\*WARNING**  
ON INSTALLATION, SET WIRE DISC TO CRIMP HEIGHT REFERENCE SETTING FOR LARGEST WIRE SIZE. CRIMP HEIGHT REFERENCE SETTINGS GREATER THAN THE VALUE SHOWN MAY CAUSE DAMAGE TO THE CRIMP TOOLING, REFER TO THE INSTRUCTION SHEET FOR PROPER SETUP AND ADJUSTMENTS.

**ATLANTIC VERSION**  
Shown on sheets 1 of 4 & 2 of 4  
(Pacific version shown on sheets 3 of 4 & 4 of 4)

LOC	DIST	REVISIONS					
A	66	P	LTN	DESCRIPTION	DATE	DWN	APVD
		E		ECR-18-007138	14MAY2018	MEH	JDG
		F		ECR-18-007741	18MAY2018	AW	CT
		G		ECR-22-149793	18AUG2022	FZ	JAH
		H		ECR-23-181911	20JUL2023	ROY	JAH

-	1	-	1	-	2119641-1	FEED CAM, AIR FEED	248
-	1	1	1	1	2119082-8	CAM, SNAIL, INSULATION ADJUSTMENT	244
-	1	1	1	1	2079764-1	WASHER, WAVE SPRING, CREST-TO-CREST	243
-	1	1	1	1	2119083-1	RETAINER, INSULATION DIAL	242
-	1	1	1	1	7-18023-7	SCR, SKT HD CAP M3 X 4.0	241
-	-	1	-	1	2119580-1	MECHANICAL FEED ASSEMBLY	239
-	1	-	1	-	2844940-1	AIR FEED MODULE	238
-	REF	REF	REF	REF	994970-2	COUNTER, MAGNETIC	164
-	1	1	1	1	2119955-1	ASSY, LUBRICATOR, SIDE FEED	113
-	1	1	1	1	2844908-1	SCREW, LOCKING	99
-	1	1	1	1	2844907-1	POST, LOCKING	98
-	1	1	1	1	455888-8	SPACER, CRIMPER	82
-	1	1	1	1	22278-8	SPRING, COMPRESSION	77
-	1	1	1	1	854769-4	HOLDER, INS	74
-	1	1	1	1	1803607-3	DOCUMENTATION PACKAGE	71
-	1	1	1	1	2119791-6	DEPRESSOR, WIRE	70
-	1	1	1	1	2119740-1	TAG, IDENTIFICATION	67
-	2	2	2	2	2168078-1	SCREW, DRIVE, RH, RoHS, 2 x .188	66
-	1	1	1	1	2168083-2	SCR, SKT HD CAP, RoHS, M4 X 8.0	60
-	1	1	1	1	5-18022-5	SCR, HEX HD CAP, M4 X 6.0	59
-	1	1	1	1	21028-2	PIN, SLOTTED SPRING .062 X .250	58
-	1	1	1	1	1338685-1	PAWL, FEED	56
-	4	4	4	4	2168083-3	SCR, SKT HD CAP, RoHS, M4 X 12.0	54
-	2	2	2	2	2168083-3	SCR, SKT HD CAP, RoHS, M4 X 12.0	53
-	1	1	1	1	5018030-1	NUT, HEX, REG, RoHS, M3	52
-	1	1	1	1	811242-5	BUMPER, HOLD DOWN	51
-	1	1	1	1	690753-2	SPACER, TONKER	50
-	1	2	1	2	18023-9	SCR, SKT HD CAP M4 X 6.0	49
-	-	1	-	1	2119652-1	FEED CAM, PRE FEED	48
-	-	1	-	1	2119653-1	FEED CAM, POST FEED	47
-	1	1	1	1	1803583-9	APPLICATOR BASIC ASSEMBLY, SF	46
-	1	1	1	1	1803515-1	RAM ASSEMBLY, SF ATLANTIC	44
-	1	1	1	1	1803602-1	SCR, BHSC, RoHS (M8 X 25)	41
-	1	1	1	1	1752356-1	SUPPORT, TERMINAL	34
-	2	2	2	2	2079383-5	SCR, BHSC, RoHS (M4 X 20)	33
-	2	2	2	2	3-2844962-2	SPACER, CYLINDRICAL, STRIP GUIDE	30
-	1	1	1	1	2844992-1	ASSEMBLY, STRIP GUIDE	29
-	1	1	1	1	1-455888-0	SPACER, CRIMPER	28
-	1	1	1	1	1320928-2	STRIP GUIDE	24
-	1	1	1	1	2168083-2	SCR, SKT HD CAP, RoHS, M4 X 8.0	21
-	2	2	2	2	1-18028-2	WASHER, FLAT, REG M4	20
-	1	1	1	1	2119533-1	STRIPPER, SIDE FEED	19
-	1	1	1	1	2119806-1	INSERT, SHEAR	13
-	1	1	1	1	3-22280-3	SPRING, COMPRESSION	12
-	1	1	1	1	1-356885-4	STOP, SHEAR	11
-	1	1	1	1	2119805-1	SHEAR HOLDER, FRONT	10
-	1	1	1	1	1803095-1	FLOATING SHEAR, FRONT	9
-	1	2	2	1	1-1803079-2	ANVIL, WITH STABILIZER	8
-	1	1	1	1	4-240641-2	SPACER	7
-	-	-	-	-	-	-	6
-	1	1	1	1	1-2119780-1	DEPRESSOR, SHEAR	5
-	1	1	1	1	238011-2	BLOCK, CRIMPER SPACER	4
-	1	2	2	1	1-1803187-3	CRIMPER, INSULATION F	3
-	1	1	1	1	455888-6	SPACER, CRIMPER	2
-	1	2	2	1	3-456406-3	CRIMPER, WIRE PREMIUM	1

DIMENSIONS:		TOLERANCES UNLESS OTHERWISE SPECIFIED:		MATERIAL:		FINISH:	
mm	0 PLC ±	1 PLC ±	2 PLC ±	3 PLC ±	4 PLC ±	ANGLES ±	FINISH ±

OWN	T. YIN	03SEP2012	TE Connectivity Harrisburg, PA 17105-3608
CHK	G. BAILEY	03SEP2012	
APVD	S. XI	03SEP2012	
NAME			Ocean Side Feed Applicator
SIZE			A1
CAGE CODE			00779
DRAWING NO			2151742
RESTRICTED TO			Customer Accessible Production Drawing
SCALE			1:2
SHEET			1 of 4
REV			H

LOC	DIST	REVISIONS					
		P	LTN	DESCRIPTION	DATE	DWN	APVD
A	66	-	-	SEE SHEET 1	-	-	-

# FEED TYPE MECHANICAL

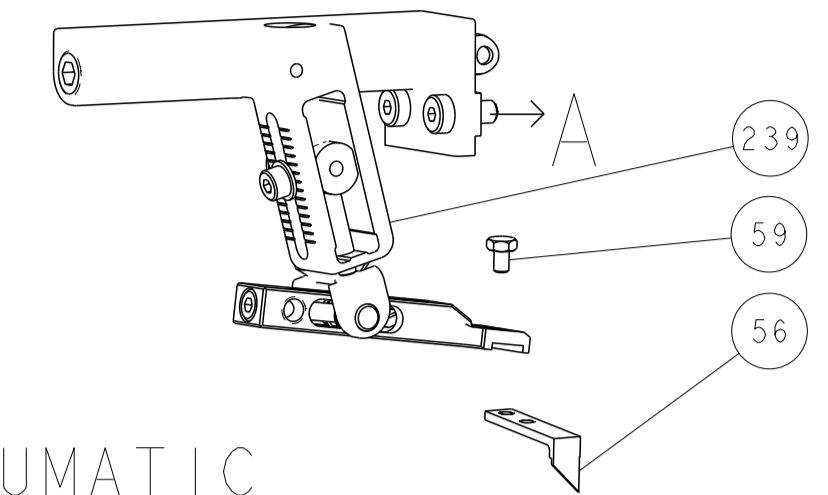

## PNEUMATIC

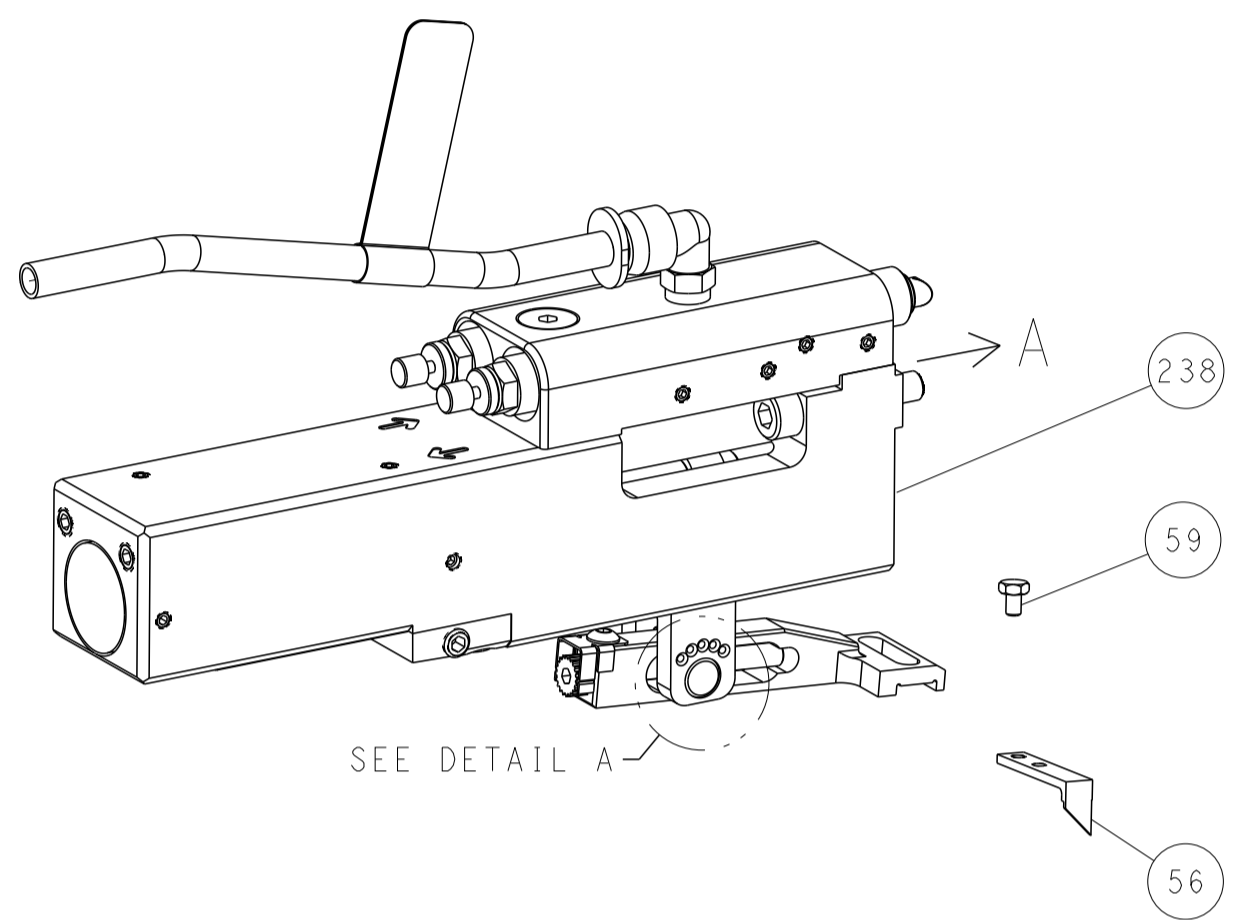

## FEED SPRING SETTING POSITION (SHOWN FROM REAR SIDE)



DETAIL A

# CAM POSITIONS

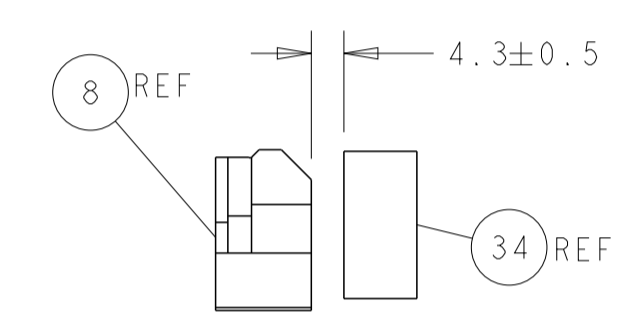
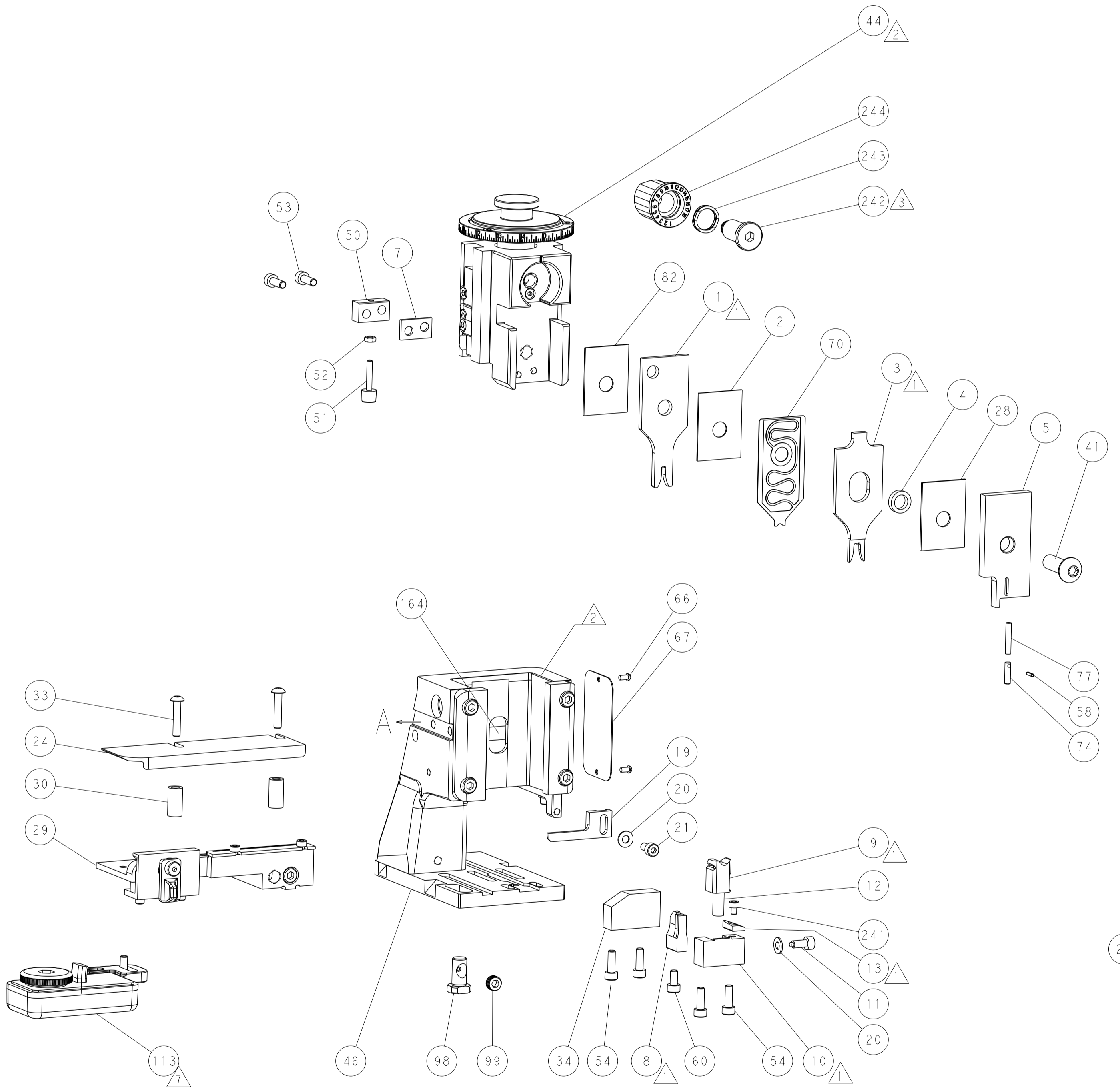
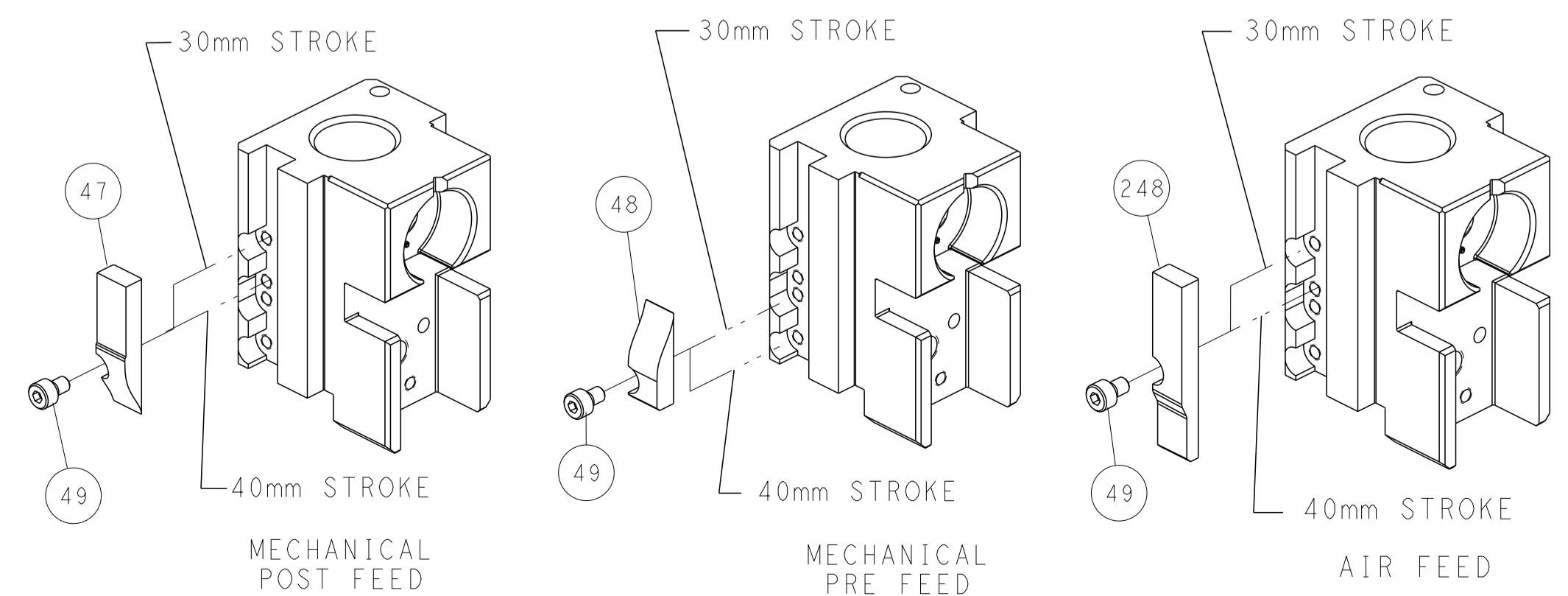

TERMINAL SUPPORT LOCATION

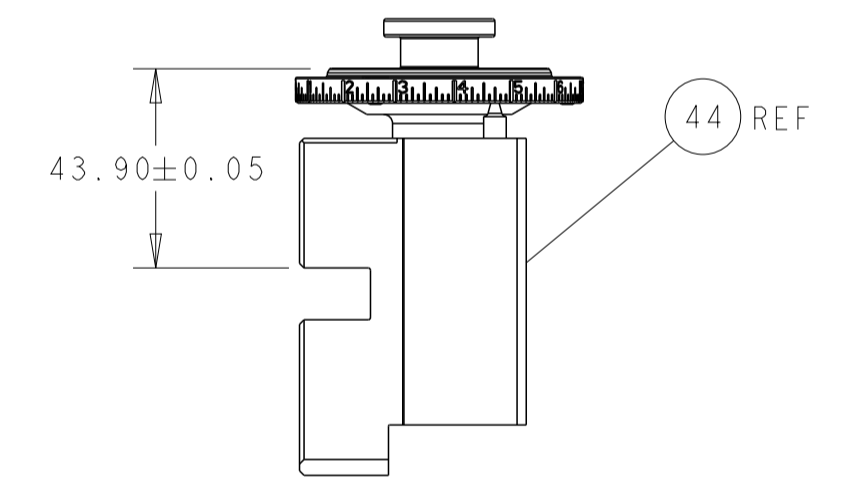

RAM SET-UP

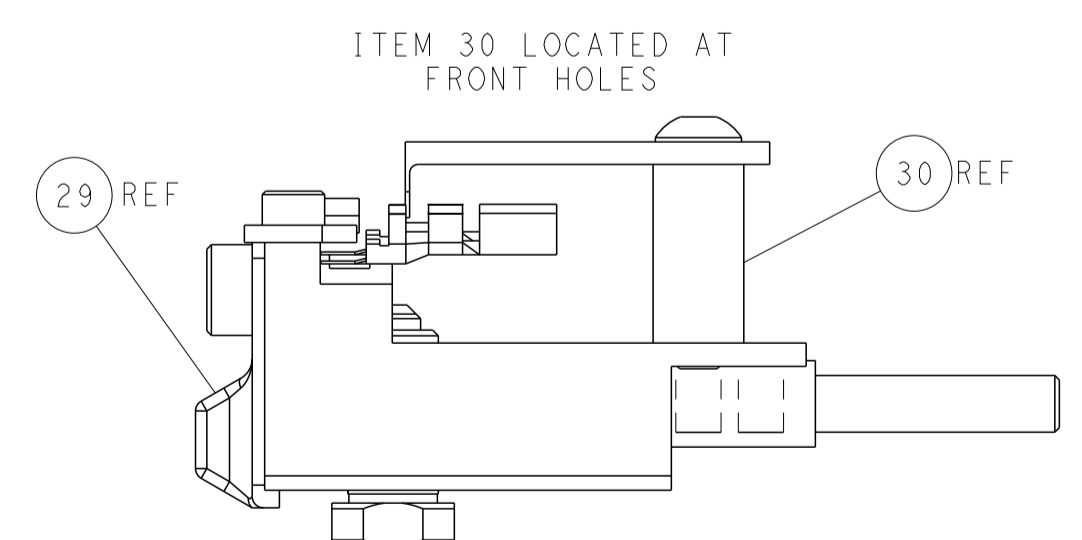

FEED TRACK POSITION GUIDE BY INSULATION BARREL

**ATLANTIC VERSION**  
 Shown on sheets 1 of 4 & 2 of 4  
 (Pacific version shown on sheets 3 of 4 & 4 of 4)

DIMENSIONS: mm 		TOLERANCES UNLESS OTHERWISE SPECIFIED: 0 PLC ± 1 PLC ± 2 PLC ± 3 PLC ± 4 PLC ± ANGLES ±		DWN Y. YIN 03SEP2012 CHK G. BAILEY 03SEP2012 APVD S. XI 03SEP2012 NAME Ocean Side Feed Applicator SIZE CAGE CODE DRAWING NO RESTRICTED TO A1 00779 ©=2151742 Customer Accessible Production Drawing SCALE 1:2 SHEET 2 of 4 REV H	
MATERIAL:		FINISH:		WEIGHT:	

PART NUMBER	REVISION	DESCRIPTION	FEED TYPE
2-2151742-1	H	FINE CRIMP HEIGHT ADJUST	MECHANICAL
2-2151742-2	H	FINE CRIMP HEIGHT ADJUST	PNEUMATIC
7-2151742-7	D	CRIMP TOOLING KIT	-

PACIFIC VERSION TERMINATOR  
INTERFACE ADAPTER



APPLICATOR DATA		
CRIMP	SIZE	TYPE
WIRE	2.29 mm [.090]	F
INSUL	4.06 mm [.160]	F

APPLICATOR INSTRUCTIONS  
408-35042

TERMINAL DATA: TE TERMINAL		TE CRIMP SPECIFICATION	
TERMINAL NAME: RECEPTACLE CONTACT NEXT GENERATION SOFET SHELL			
WIRE STRIP LENGTH		INSULATION DIAMETER RANGE	
4.20-4.80 mm [1.65-.189 IN]		∅3.40-3.70 mm [1.34-.146 IN]	
TERMINAL APPLICATION SPECIFICATION	114-106118		
TERMINALS APPLIED			
TE TERMINAL	TE TERMINAL	TE TERMINAL	TE TERMINAL
1971781-1	1971781-2	1971782-1	1971782-2

WIRE SIZE	CRIMP HEIGHT mm [INCH]	CRIMP HEIGHT REFERENCE SETTING
14 AWG OR 2.10mm2	1.63+/-0.05 [1.064+/-0.02]	9.0

- RECOMMENDED SPARE PARTS
- REFER TO SUPPLIED INSTRUCTION SHEET FOR CLEANING, LUBRICATION AND STORAGE OF APPLICATOR.
- APPLY PART NUMBER 2-23419-6 LOCTITE TO THREADS OF ITEM 242.
- CRIMP HEIGHT REFERENCE SETTING WAS THE SETTING USED WHEN THE APPLICATOR WAS QUALIFIED AT THE FACTORY. ADJUSTMENT MAY BE NECESSARY WHEN RUNNING APPLICATOR IN THE FIELD.
- TERMINAL 1971781 REVISION 11. TERMINAL 1971782 REVISION 10.
- 6. UNLESS SPECIFIED OTHERWISE TORQUE VALUES SHALL BE USED PER DOCUMENT, 101-35000.
- TERMINAL LUBRICANT IS RECOMMENDED.

**\*WARNING**  
ON INSTALLATION, SET WIRE DISC TO CRIMP HEIGHT REFERENCE SETTING FOR LARGEST WIRE SIZE. CRIMP HEIGHT REFERENCE SETTINGS GREATER THAN THE VALUE SHOWN MAY CAUSE DAMAGE TO THE CRIMP TOOLING, REFER TO THE INSTRUCTION SHEET FOR PROPER SETUP AND ADJUSTMENTS.

PACIFIC VERSION  
Shown on sheets 3 of 4 & 4 of 4  
(Atlantic version shown on sheets 1 of 4 & 2 of 4)

LOC	DIST	REVISIONS					
A	66	P	LTN	DESCRIPTION	DATE	OWN	APVD
-	-	-	-	SEE SHEET 1	-	-	-

-	1	1	2119082-8	CAM, SNAIL, INSULATION ADJUSTMENT	244
-	1	1	2079764-1	WASHER, WAVE SPRING, CREST-TO-CREST	243
-	1	1	2119083-1	RETAINER, INSULATION DIAL	242
-	1	1	7-18023-7	SCR, SKT HD CAP M3 X 4.0	241
-	-	1	2119580-1	MECHANICAL FEED ASSEMBLY	239
-	1	-	2844940-1	AIR FEED MODULE	238
-	REF	REF	994970-2	COUNTER, MAGNETIC	164
-	1	-	2119641-2	FEED CAM, AIR FEED	151
-	1	1	2168083-8	SCR, SKT HD CAP, RoHS, M4 X 16	144
-	4	4	2168083-9	SCR, SKT HD CAP, RoHS, M4 X 20	143
-	-	1	2119653-2	FEED CAM, POST FEED	142
-	1	1	1-1803583-0	APPLICATOR BASIC ASSEMBLY, SF	141
-	1	1	1803516-1	RAM ASSEMBLY, SF PACIFIC	140
-	1	1	2119955-1	ASSY, LUBRICATOR, SIDE FEED	113
-	1	1	2844908-1	SCREW, LOCKING	99
-	1	1	2844907-1	POST, LOCKING	98
-	1	1	455888-8	SPACER, CRIMPER	82
-	1	1	22278-8	SPRING, COMPRESSION	77
-	1	1	854769-4	HOLDER, INS	74
-	1	1	1803607-3	DOCUMENTATION PACKAGE	71
-	1	1	2119791-6	DEPRESSOR, WIRE	70
-	1	1	2119740-1	TAG, IDENTIFICATION	67
-	2	2	2168078-1	SCREW, DRIVE, RH, RoHS, 2 x .188	66
-	1	1	5-18022-5	SCR, HEX HD CAP, M4 X 6.0	59
-	1	1	21028-2	PIN, SLOTTED SPRING .062 X .250	58
-	1	1	1338685-1	PAWL, FEED	56
-	2	2	2168083-3	SCR, SKT HD CAP, RoHS, M4 X 12.0	53
-	1	1	5018030-1	NUT, HEX, REG, RoHS, M3	52
-	1	1	811242-5	BUMPER, HOLD DOWN	51
-	1	1	690753-2	SPACER, TONKER	50
-	1	2	18023-9	SCR, SKT HD CAP M4 X 6.0	49
-	-	1	2119652-1	FEED CAM, PRE FEED	48
-	1	1	1803602-1	SCR, BHSC, RoHS (M8 X 25)	41
-	1	1	1752356-1	SUPPORT, TERMINAL	34
-	2	2	2079383-5	SCR, BHSC, RoHS (M4 X 20)	33
-	2	2	3-2844962-2	SPACER, CYLINDRICAL, STRIP GUIDE	30
-	1	1	2844992-1	ASSEMBLY, STRIP GUIDE	29
-	1	1	1-455888-0	SPACER, CRIMPER	28
-	1	1	1320928-2	STRIP GUIDE	24
-	1	1	2168083-2	SCR, SKT HD CAP, RoHS, M4 X 8.0	21
-	2	2	1-18028-2	WASHER, FLAT, REG M4	20
-	1	1	2119533-1	STRIPPER, SIDE FEED	19
-	1	1	2119806-1	INSERT, SHEAR	13
-	1	1	3-22280-3	SPRING, COMPRESSION	12
-	1	1	1-356885-4	STOP, SHEAR	11
-	1	1	2119805-1	SHEAR HOLDER, FRONT	10
-	1	1	1803095-1	FLOATING SHEAR, FRONT	9
-	1	1	1-1803079-2	ANVIL, WITH STABILIZER	8
-	1	1	4-240641-2	SPACER	7
-	-	-	-	-	6
-	1	1	1-2119780-1	DEPRESSOR, SHEAR	5
-	1	1	238011-2	BLOCK, CRIMPER SPACER	4
-	1	1	9-1803187-3	CRIMPER, INSULATION F	3
-	1	1	455888-6	SPACER, CRIMPER	2
-	1	1	3-456406-3	CRIMPER, WIRE PREMIUM	1

DIMENSIONS:		TOLERANCES UNLESS OTHERWISE SPECIFIED:		MATERIAL:		FINISH:	
mm	0 PLC ±	1 PLC ±	2 PLC ±	3 PLC ±	4 PLC ±	ANGLES	FINISH

OWN	CHK	APVD	DATE	NAME	SIZE	CAGE CODE	DRAWING NO	RESTRICTED TO
Y. YIN	G. BAILEY	S. XI	03SEP2012	G. BAILEY	A1	00779	2151742	-

Customer Accessible Production Drawing SCALE 1:2 SHEET 3 OF 4 REV H

LOC	DIST	REVISIONS					
A	66	P	LTN	DESCRIPTION	DATE	OWN	APVD
		-		SEE SHEET 1	-	-	-

# FEED TYPE MECHANICAL

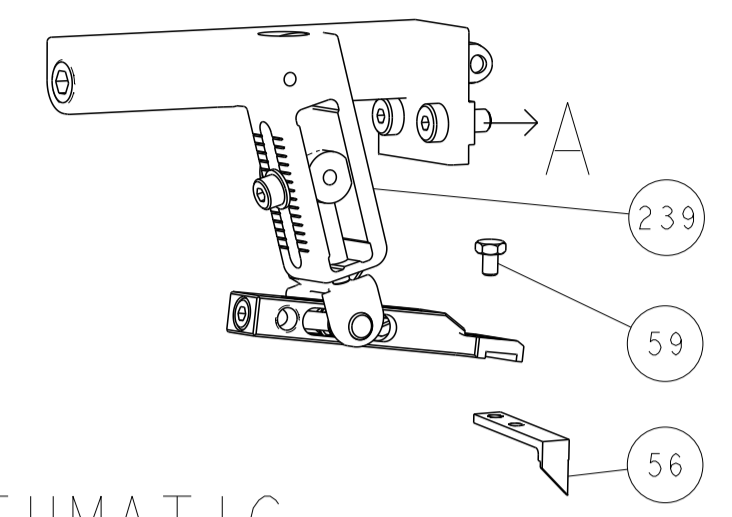

## PNEUMATIC

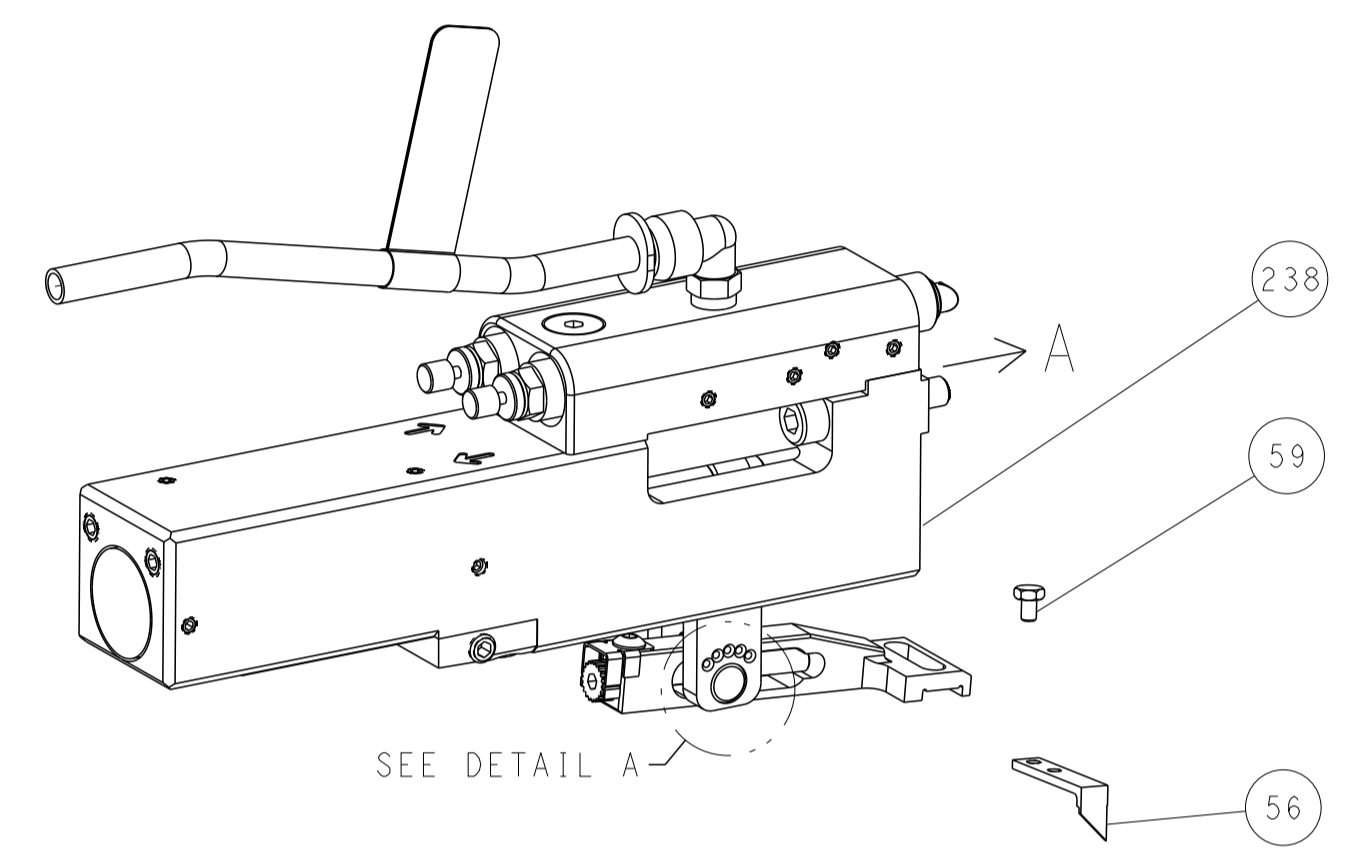

### FEED SPRING SETTING POSITION (SHOWN FROM REAR SIDE)



DETAIL A

## CAM POSITIONS

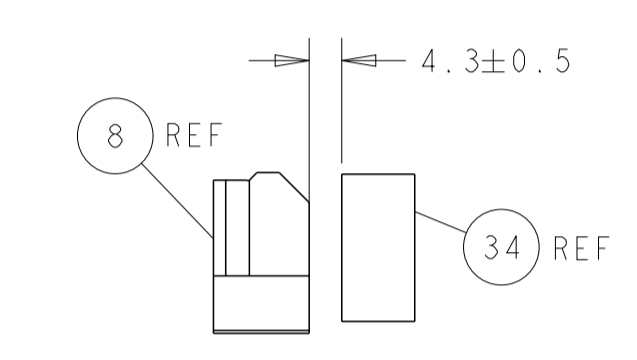
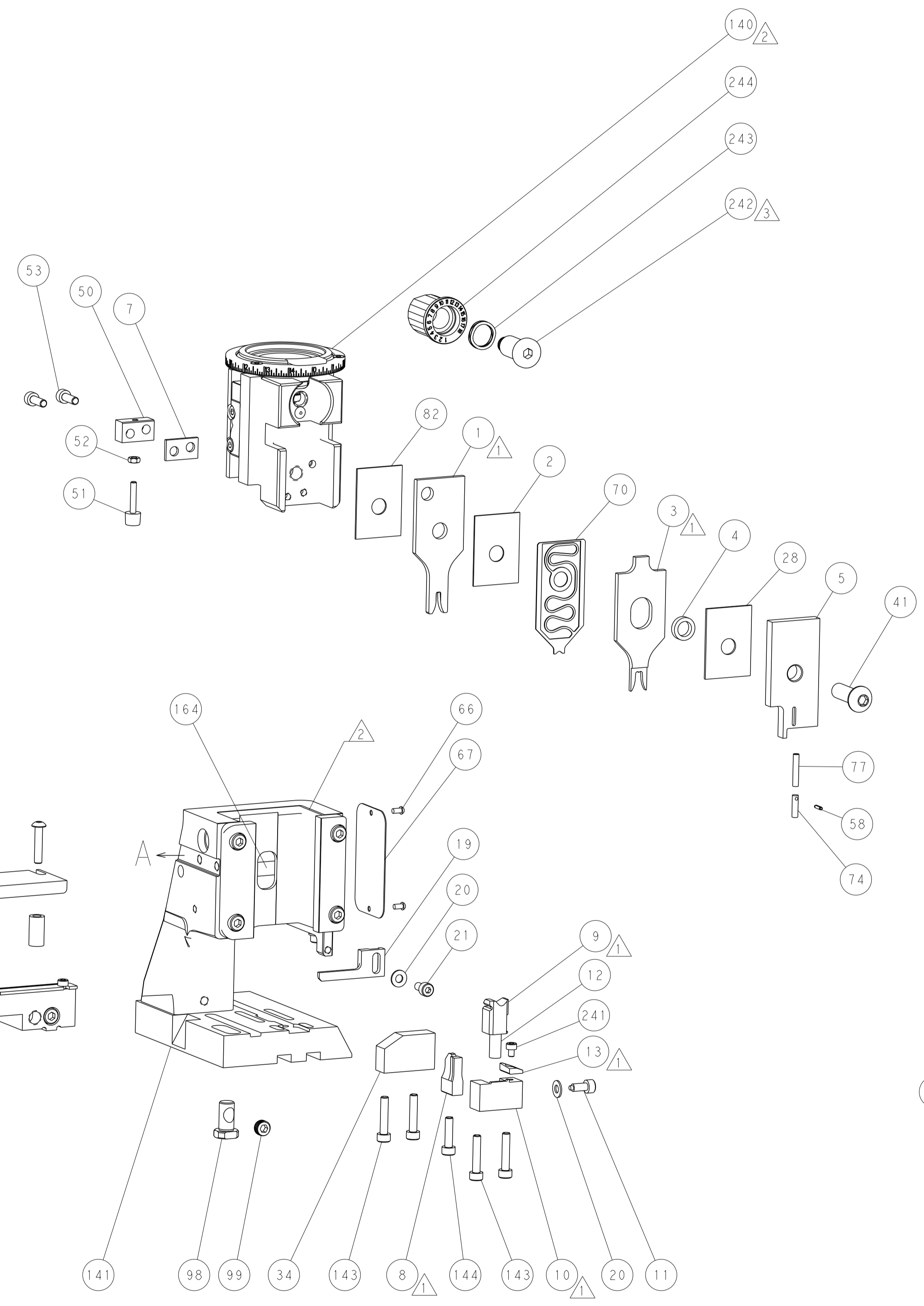
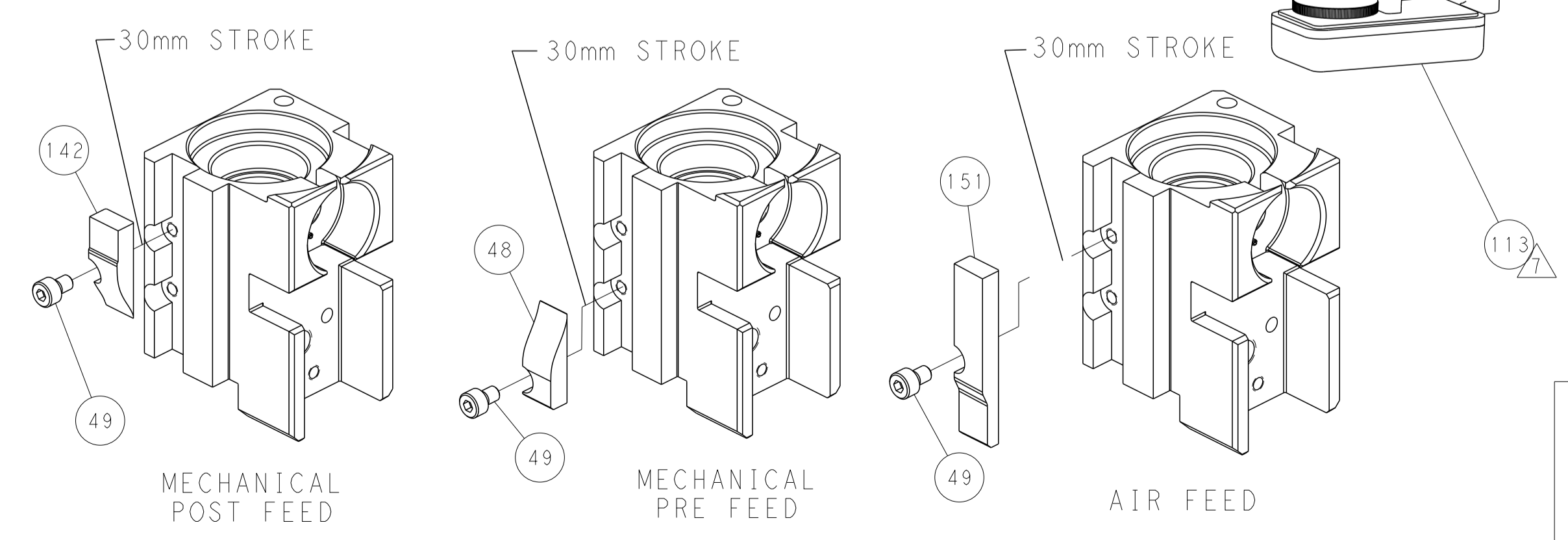

TERMINAL SUPPORT LOCATION

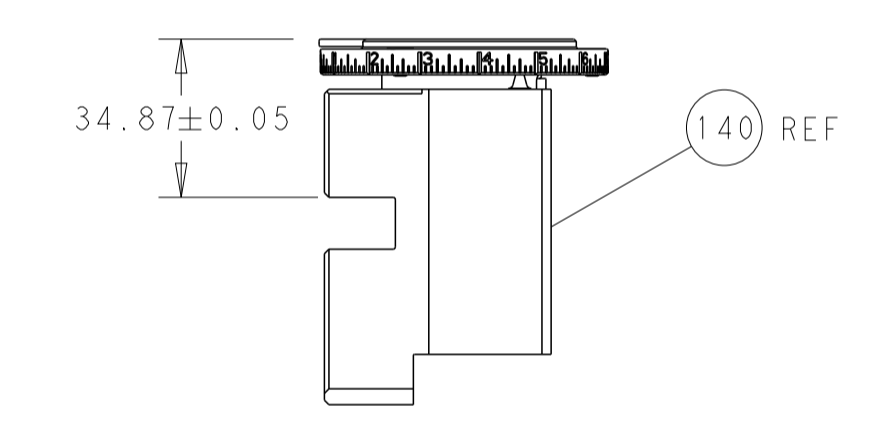

RAM SET-UP

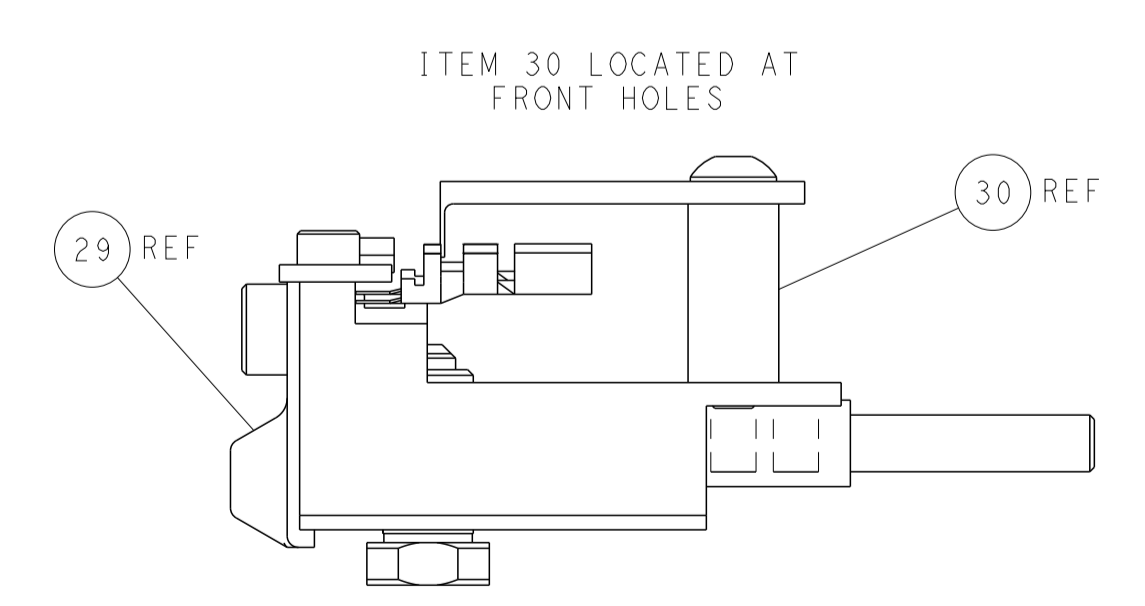

FEED TRACK POSITION  
GUIDE BY INSULATION BARREL

**PACIFIC VERSION**  
 Shown on sheets 3 of 4 & 4 of 4  
 (Atlantic version shown on sheets 1 of 4 & 2 of 4)

<small>THIS DRAWING IS UNPUBLISHED. RELEASED FOR PUBLICATION. ALL RIGHTS RESERVED. © 2000 BY TYCO ELECTRONICS CORPORATION. THIS DRAWING IS THE PROPERTY OF TYCO ELECTRONICS CORPORATION AND IS NOT TO BE REPRODUCED OR TRANSMITTED IN ANY FORM OR BY ANY MEANS, ELECTRONIC OR MECHANICAL, INCLUDING PHOTOCOPYING, RECORDING, OR BY ANY INFORMATION STORAGE AND RETRIEVAL SYSTEM, WITHOUT THE WRITTEN PERMISSION OF TYCO ELECTRONICS CORPORATION.</small>		DWN Y. YIN 03SEP2012 CHK G. BAILEY 03SEP2012 APVD S. XI 03SEP2012	TE Connectivity Harrisburg, PA 17105-3608
DIMENSIONS: mm TOLERANCES UNLESS OTHERWISE SPECIFIED: 0 PLC ± 1 PLC ± 2 PLC ± 3 PLC ± 4 PLC ± ANGLES FINISH ±		NAME Ocean Side Feed Applicator APPLICATION SPEC SIZE CAGE CODE DRAWING NO WEIGHT A1 00779 C=2151742	RESTRICTED TO SCALE 1:2 SHEET 4 OF 4 REV H
MATERIAL:		Customer Accessible Production Drawing	