

PART No.	mPm PART No.	DESCRIPTION
1210230487	C3221N21	TYPE A 2P PG11 BLACK NBR PROFILE GASKET
1210230491	C3231N21	TYPE A 3P PG11 BLACK NBR PROFILE GASKET
1210230490	C32309N21	TYPE A 3P PG9 BLACK NBR PROFILE GASKET
1210230489	C3221N61	TYPE A 2P PG11 BLACK NBR PROFILE GASKET
1210240322	C3221N2L2R	TYPE A 2P PG11 BLACK VITON PROFILE GASKET & SCREW RING NUT & GROMMET IN BRASS
1210230778	C32212N21	TYPE A 2P 1/2" GAS BLACK NBR PROFILE GASKET

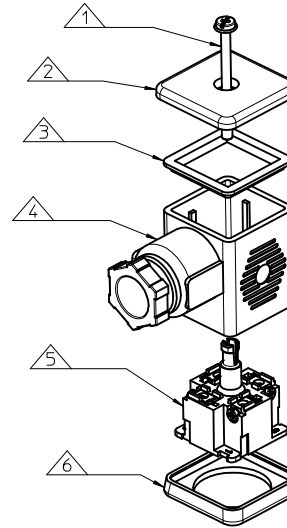

ITEM	DESCRIPTION
1	SCREW
2	CAP
3	G16 PROFILE GASKET
4	COVER ASSEMBLY
5	INSERT ASSEMBLY
6	G11 PROFILE GASKET

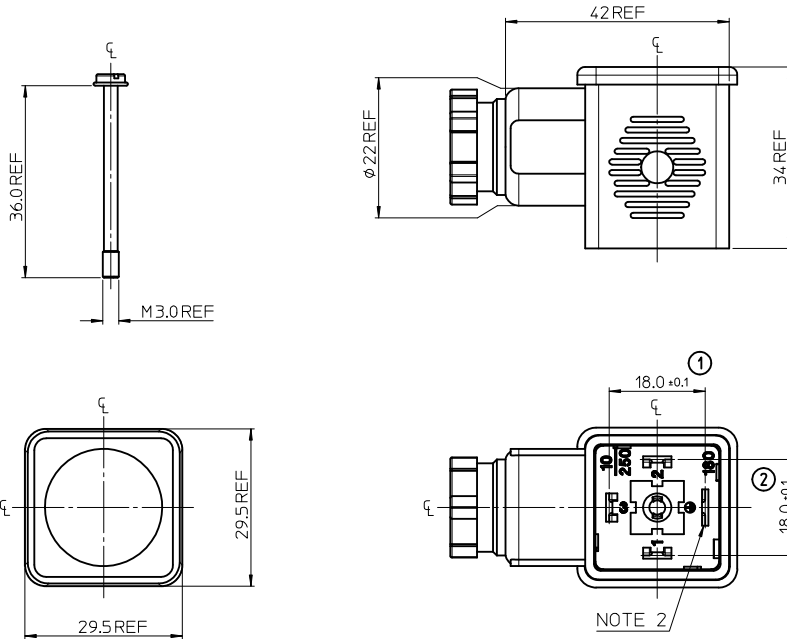

C32211N21**

SERIES _____
 C32= INTERNAL THREAD FORM A
 POLES _____
 2= 2 POLE, 3= 3 POLE
 THREAD SIZE _____
 09= PG9, 11= PG11, M6= M16x1.5, M0= M20x1.5, 12= 1/2" GAS
 MATERIAL AND HOUSING COLOUR _____
 G= PA6 GRAY, N= PA6 BLACK, W= PA66 BLACK V0, T = TRANSPARENT
 GROUND POSITION _____
 0= UNMOUNTED, 2= H12, 3= H3, 6= H6, 9= H9
 SCREW AND GASKET _____
 1= NBR PROFILE GASKET & SCREW
 2= NBR FLAT GASKET & SCREW
 3= WHITE SILICON PROFILE GASKET & SCREW
 4= WHITE SILICON FLAT GASKET & SCREW
 L= VITON FLAT GASKET, NO SCREW
 NON STANDARD COMPONENTS _____
 2R= RING NUT & GROMMET IN BRASS

- NOTES
- PLEASE SEE CHART FOR CURRENTLY CONFIGURED PART NUMBERS. FOR SPECIFIC PART NUMBERS PLEASE CONTACT SALES OR CONSULT THE INTELLIGENT PART NUMBERS IN THE TABLE ATTACHED
 - EARTH POSITION SHOWN, H12
 - FOR PACKAGING SEE PACKAGING SPEC PK-121023-C32
 - PRODUCT SPEC: SEE PS-121201-001

LAST INSPECTION NUMBER 2

ORIGINAL RELEASE EC NO: WEU2011-0570 DRAWN: JOCONNOR 2011/05/10 CHKD: _____ APPR: EFOLAN 2011/05/25	QUALITY SYMBOLS	GENERAL TOLERANCES (UNLESS SPECIFIED)	DIMENSION STYLE	SCALE	DESIGN UNITS	THIRD ANGLE PROJECTION	
	▽=0 ▽=0	m/m INCH	MM ONLY	1.5:1	METRIC		
		4 PLACES ± --- ± --- 3 PLACES ± --- ± --- 2 PLACES ± 0.1 ± --- 1 PLACE ± 0.2 ± ---	DRAWN BY DATE JOCONNOR 2011/05/10	TITLE C32 SERIES INTERNAL THREAD			
		ANGULAR ± ---°	CHECKED BY DATE DMAHER 2011/05/10				
	DRAFT WHERE APPLICABLE MUST REMAIN WITHIN DIMENSIONS	APPROVED BY DATE EFOLAN 2011/05/25	MATERIAL NO. SEE CHART DOCUMENT NO. SD-121023-002				
			SHEET NO. 1 OF 1				