

# Wheel Speed Sensor

iGMR based Wheel Speed Sensor

## TLE5041plusC

### Data Sheet

V 1.2, 2018-01-18

ATV SC

**Edition 2018-01-18**

**Published by  
Infineon Technologies AG  
81726 Munich, Germany**

**© 2018 Infineon Technologies AG  
All Rights Reserved.**

### **Legal Disclaimer**

The information given in this document shall in no event be regarded as a guarantee of conditions or characteristics. With respect to any examples or hints given herein, any typical values stated herein and/or any information regarding the application of the device, Infineon Technologies hereby disclaims any and all warranties and liabilities of any kind, including without limitation, warranties of non-infringement of intellectual property rights of any third party.

### **Information**

For further information on technology, delivery terms and conditions and prices, please contact the nearest Infineon Technologies Office ([www.infineon.com](http://www.infineon.com)).

### **Warnings**

Due to technical requirements, components may contain dangerous substances. For information on the types in question, please contact the nearest Infineon Technologies Office.

Infineon Technologies components may be used in life-support devices or systems only with the express written approval of Infineon Technologies, if a failure of such components can reasonably be expected to cause the failure of that life-support device or system or to affect the safety or effectiveness of that device or system. Life support devices or systems are intended to be implanted in the human body or to support and/or maintain and sustain and/or protect human life. If they fail, it is reasonable to assume that the health of the user or other persons may be endangered.

Revision History January 2018, V 1.2	
Previous version	V 1.1, 2013-05
Change	Subjects (major changes since previous revision)
	V 1.2
	Update SP Numbers due to PCN 2017-106
	V 1.1
Chapter 1	Sensor picture added
Chapter 3.4.1	Periode jitter extended, dB <sub>x</sub> down to 1mT. Test conditions removed. See Table 4
Chapter 3.4.1	Equation added to Figure 12 “Period jitter definition is valid for measurement on rising-to-rising or falling-to-falling edge” on Page 18
Chapter 3.4.2.1	Magnetic induction areas where the jitter exceeds S <sub>ii1</sub> extended to the lifetime of the sensor. Comment “ valid at 0 ” hours removed from Table 6 “Magnetic induction area where period jitter exceeds S <sub>ii1</sub> ” on Page 19

#### Trademarks of Infineon Technologies AG

AURIX™, C166™, CanPAK™, CIPOST™, CIPURSE™, EconoPACK™, CoolMOS™, CoolSET™, CORECONTROL™, CROSSAVE™, DAVE™, EasyPIM™, EconoBRIDGE™, EconoDUAL™, EconoPIM™, EiceDRIVER™, eupec™, FCOS™, HITFET™, HybridPACK™, I<sup>2</sup>RF™, ISOFACE™, IsoPACK™, MIPAQ™, ModSTACK™, my-d™, NovalithIC™, OptiMOS™, ORIGA™, PRIMARION™, PrimePACK™, PrimeSTACK™, PRO-SIL™, PROFET™, RASIC™, ReverSave™, SatRIC™, SIEGET™, SINDRION™, SIPMOS™, SmartLEWIS™, SOLID FLASH™, TEMPFET™, thinQ!™, TRENCHSTOP™, TriCore™.

#### Other Trademarks

Advance Design System™ (ADS) of Agilent Technologies, AMBA™, ARM™, MULTI-ICE™, KEIL™, PRIMECELL™, REALVIEW™, THUMB™, μVision™ of ARM Limited, UK. AUTOSAR™ is licensed by AUTOSAR development partnership. Bluetooth™ of Bluetooth SIG Inc. CAT-iq™ of DECT Forum. COLOSSUS™, FirstGPS™ of Trimble Navigation Ltd. EMV™ of EMVCo, LLC (Visa Holdings Inc.). EPCOS™ of Epcos AG. FLEXGO™ of Microsoft Corporation. FlexRay™ is licensed by FlexRay Consortium. HYPERTERMINAL™ of Hilgraeve Incorporated. IEC™ of Commission Electrotechnique Internationale. IrDA™ of Infrared Data Association Corporation. ISO™ of INTERNATIONAL ORGANIZATION FOR STANDARDIZATION. MATLAB™ of MathWorks, Inc. MAXIM™ of Maxim Integrated Products, Inc. MICROTEC™, NUCLEUS™ of Mentor Graphics Corporation. Mifare™ of NXP. MIPI™ of MIPI Alliance, Inc. MIPS™ of MIPS Technologies, Inc., USA. muRata™ of MURATA MANUFACTURING CO., MICROWAVE OFFICE™ (MWO) of Applied Wave Research Inc., OmniVision™ of OmniVision Technologies, Inc. Openwave™ Openwave Systems Inc. RED HAT™ Red Hat, Inc. RFMD™ RF Micro Devices, Inc. SIRIUS™ of Sirius Satellite Radio Inc. SOLARIS™ of Sun Microsystems, Inc. SPANSION™ of Spansion LLC Ltd. Symbian™ of Symbian Software Limited. TAIYO YUDEN™ of Taiyo Yuden Co. TEAKLITE™ of CEVA, Inc. TEKTRONIX™ of Tektronix Inc. TOKO™ of TOKO KABUSHIKI KAISHA TA. UNIX™ of X/Open Company Limited. VERILOG™, PALLADIUM™ of Cadence Design Systems, Inc. VLYNQ™ of Texas Instruments Incorporated. VXWORKS™, WIND RIVER™ of WIND RIVER SYSTEMS, INC. ZETEX™ of Diodes Zetex Limited.

Last Trademarks Update 2011-02-24

## Table of Contents

	<b>Table of Contents</b> .....	4
	<b>List of Figures</b> .....	5
	<b>List of Tables</b> .....	6
<b>1</b>	<b>Product Description</b> .....	7
1.1	Overview .....	7
1.2	Features .....	7
1.3	Target Applications .....	7
<b>2</b>	<b>Functional Description</b> .....	8
2.1	General .....	8
2.2	Sensitive area .....	9
2.3	Pin Description .....	9
2.4	Block Diagram .....	10
2.4.1	Uncalibrated Mode .....	11
2.4.2	Calibrated Mode .....	12
2.4.3	Behavior at Magnetic Input Signals Slower than $f_{mag} < 1\text{Hz}$ .....	12
2.4.4	Undervoltage behavior .....	12
<b>3</b>	<b>Specification</b> .....	13
3.1	Application Circuit .....	13
3.2	Absolute Maximum Ratings .....	14
3.3	Operating Range .....	15
3.4	Characteristics .....	16
3.4.1	Electrical Parameters .....	16
3.4.2	Magnetic Input Characteristics .....	18
3.4.2.1	Operating area for Period Jitter $S_{jit1}$ .....	19
3.4.3	Typical Diagrams (measured performance) .....	21
3.4.4	Electrostatic discharge protection .....	24
3.5	Electro Magnetic Compatibility (EMC) .....	24
3.5.1	ISO 7637-2:2011 and ISO 16750-2:2010 .....	25
3.5.2	ISO 7637-3:2007 .....	25
3.5.3	ISO 11452-3:2004 .....	25
<b>4</b>	<b>Package Information</b> .....	26
4.1	Package Parameters .....	26
4.2	Bending for assembly .....	26
4.3	Package surface to silicon .....	26
4.4	Package Outline .....	27
4.5	Packing .....	28
4.6	Marking .....	29
	<b>References</b> .....	30

## List of Figures

Figure 1	Side read placement of the TLE5041plusC besides a magnetic encoder wheel . . . . .	8
Figure 2	Sensing element positions of TLE5041plusC . . . . .	9
Figure 3	TLE5041plusC block diagram. . . . .	10
Figure 4	Differential amplitude and threshold $dB_{limit}$ . . . . .	10
Figure 5	TLE5041plusC differential arrangement of sensing elements . . . . .	11
Figure 6	Offset calibration of TLE5041plusC . . . . .	11
Figure 7	Undervoltage behavior . . . . .	12
Figure 8	Basic application circuit . . . . .	13
Figure 9	Advanced application circuit including protection and EMC components. . . . .	13
Figure 10	Test circuit for the TLE5041plusC . . . . .	16
Figure 11	Slew Rate definition . . . . .	17
Figure 12	Period jitter definition is valid for measurement on rising-to-rising or falling-to-falling edge. . . . .	18
Figure 13	Operating area for period jitter $S_{jit1}$ . . . . .	19
Figure 14	Supply Current = $f(T)$ (left), Supply Current Ratio $I_{High} / I_{Low} = f(T)$ (right) . . . . .	21
Figure 15	Slew Rate = $f(T)$ , $R_M = 75 \Omega$ . . . . .	21
Figure 16	Magnetic Threshold $dB_{Limit} = f(T)$ (left), Magnetic Threshold $dB_{Limit} = f(f)$ (right). . . . .	22
Figure 17	Magnetic Threshold $dB_{Limit} = f(f)$ . . . . .	22
Figure 18	Period Jitter = $f(T)$ at $dB_X = 2 \text{ mT}$ (left) , Duty Cycle = $f(T)$ at $dB_X = 2 \text{ mT}$ (right). . . . .	23
Figure 19	EMC test circuit for the TLE5041plusC. . . . .	24
Figure 20	Distance from package surface to silicon (=sensing element) . . . . .	26
Figure 21	Package dimensions. . . . .	27
Figure 22	Packing dimensions in mm . . . . .	28
Figure 23	Packing dimensions in mm . . . . .	29

## List of Tables

Table 1	Pin description . . . . .	9
Table 2	Absolute maximum ratings . . . . .	14
Table 3	Operating range . . . . .	15
Table 4	Electrical parameters . . . . .	16
Table 5	Magnetic input values . . . . .	18
Table 6	Magnetic induction area where period jitter exceeds $S_{jit1}$ . . . . .	19
Table 7	ESD protection . . . . .	24
Table 8	Conducted pulses along supply lines . . . . .	25
Table 9	Pulses by capacitive coupling on signal lines . . . . .	25
Table 10	Radiated immunity . . . . .	25
Table 11	Package parameters . . . . .	26



## 1 Product Description

### 1.1 Overview

The TLE5041plusC is a wheel speed sensor designed for sophisticated vehicle control systems. The rotational speed is sensed accurately, enabling the sensor to be used as a component of **indirect tire pressure monitoring** systems. It is based on integrated **giant magneto resistive** (GMR) elements sensitive to the direction of a magnetic field. Excellent repeatability and sensitivity is specified over a wide temperature range. To meet harsh automotive requirements, robustness to electrostatic discharge (ESD) and electromagnetic compatibility (EMC) has been maximized. State of the art BiCMOS technology is used for monolithic integration of sensing elements and signal conditioning circuitry, thus requiring no external components.

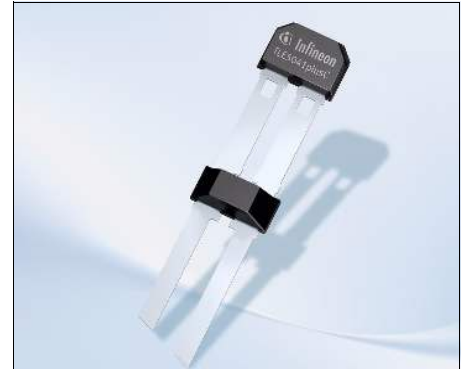

### 1.2 Features

- Low jitter
- High sensitivity
- Immunity against external magnetic disturbances
- Wide air-gap performance
- 2 mm sensing iGMR element pitch for use with magnetic encoder wheels
- Differential front end highly immune to disturbing fields
- Two-wire current interface
- Monolithic integration on a single die
- No external components required
- Insensitive to mechanical stress
- Wide junction temperature range -40°C to 170°C

### 1.3 Target Applications

Wheel speed sensing (ABS) or stability control systems with iTPMS feature.

- General wheel speed sensing (ABS)
- ESP
- Indirect tire pressure monitoring (iTPMS)

Product Type	Marking	Ordering Code	Package
TLE5041plusC	541CPS	SP001952936	PG-SSO-2-53



## 2 Functional Description

The integrated GMR sensor detects differential magnetic fields in x-direction. Two iGMR sensing elements are arranged at a distance of 2mm. Their output signals are processed differentially. To detect the motion of objects the magnetic field must be provided by a magnetized encoder wheel mounted on the rotating axis.

Magnetic offsets and device offsets are cancelled by a self-calibration algorithm. Self-calibration is done after start up and requires only a short history of magnetic input. After calibration switching occurs exactly at the zero crossing for sinusoidal signals or generally speaking the arithmethical mean of any magnetic input signal.

Switching is indicated by a high or low supply current level.

### 2.1 General

The sensor is sensitive to magnetic field gradients in x direction. In **Figure 1** the typical placement of the TLE5041plusC facing a magnetic encoder wheel is shown. The figure also indicates the coordinate system, which is valid throughout this document. Other sensor positions and encoder wheels are possible, the coordinate system is therefore related to the sensor. The iGMR structures (sensitive areas) are located at the front side of the package which is marked.

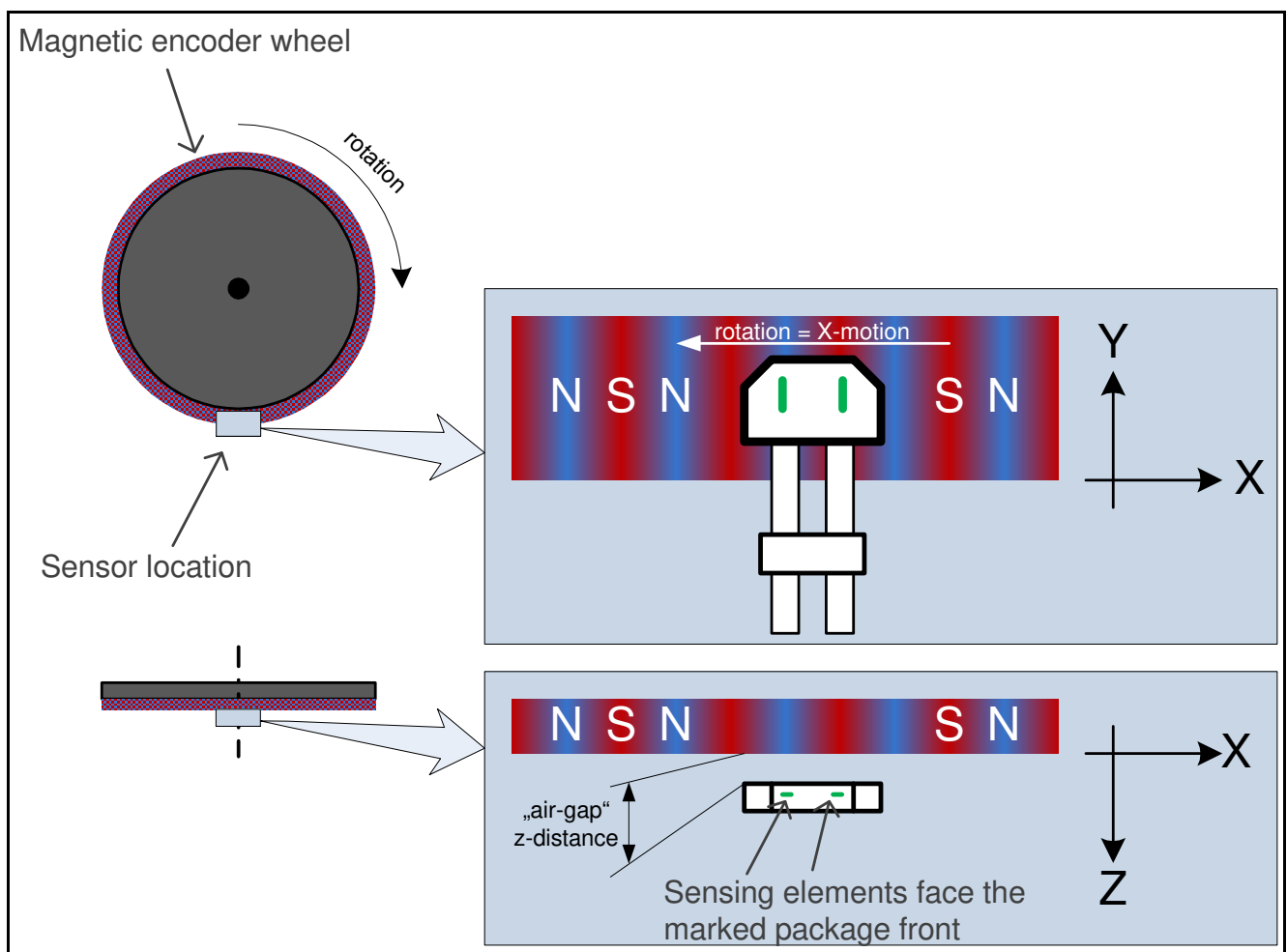

Figure 1 Side read placement of the TLE5041plusC besides a magnetic encoder wheel



## 2.2 Sensitive area

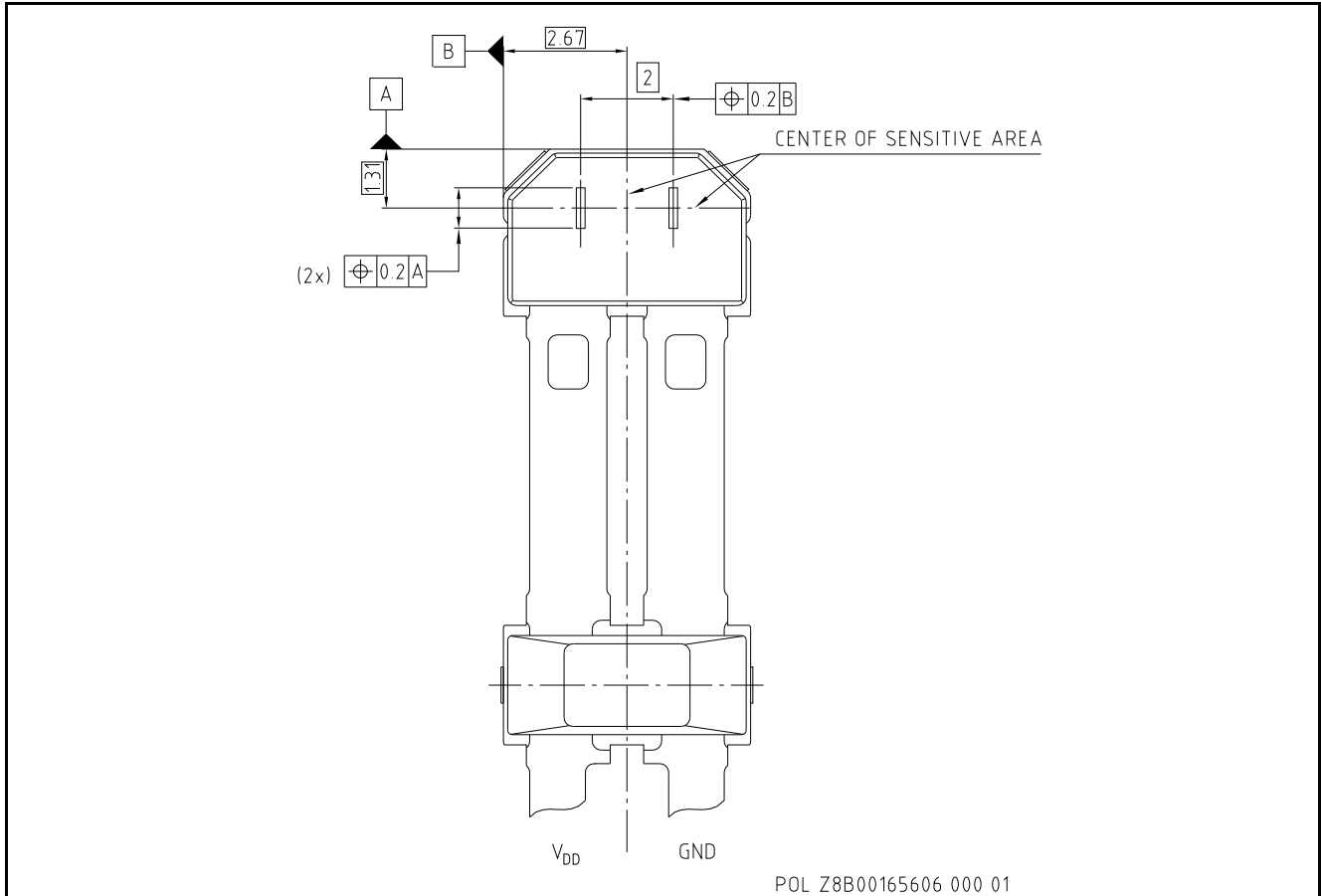

Figure 2 Sensing element positions of TLE5041plusC

## 2.3 Pin Description

Table 1 Pin description

Pin No.	Symbol	In/Out	Function
1	VDD	Supply	
2	GND	Supply	Output node

## 2.4 Block Diagram

The device is supplied internally by a voltage regulator within the PMU. An on chip oscillator serves as clock generator for the digital part of the circuit.

The TLE5041plusC incorporates two GMR sensing elements spaced at 2mm. The signal path is comprised of a differential amplifier, a noise limiting low pass filter and two comparators. An offset cancellation loop is in place to compensate magnetic and electric offsets. The regulation loop consists of a tracking A/D converter, the digital core to evaluate the offset and the offset DAC to feed in the corrective voltage.

The current interface is triggered by the main comparator.

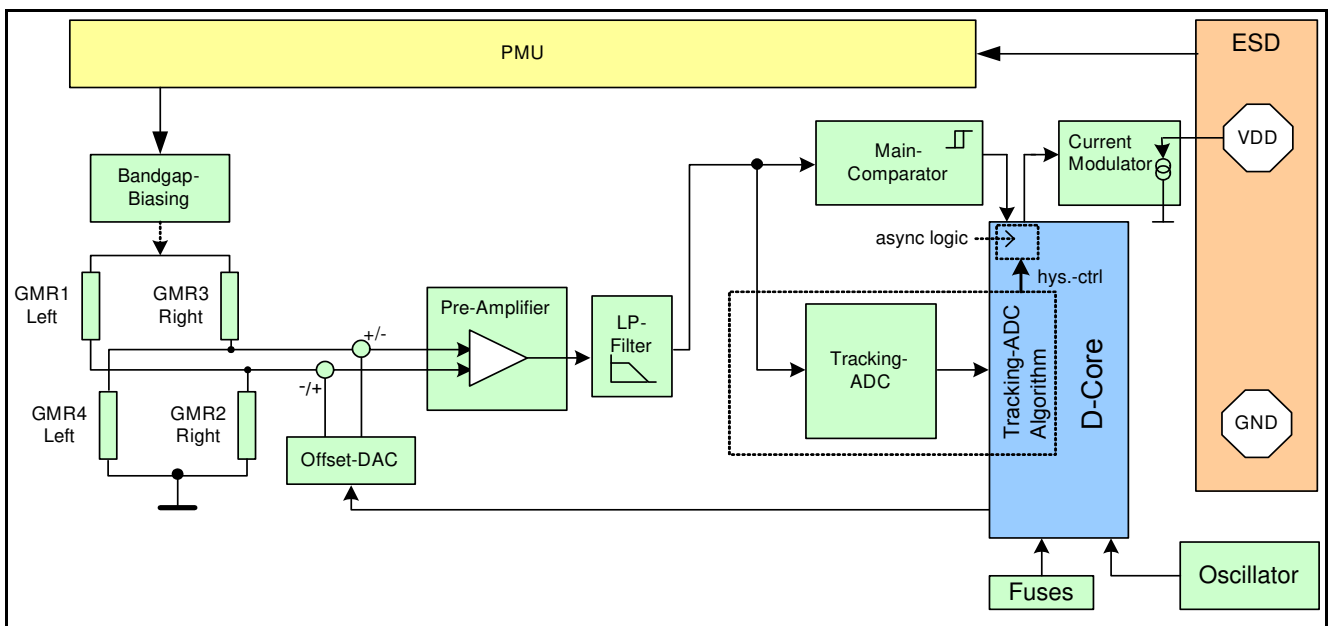

Figure 3 TLE5041plusC block diagram

The device can be in one of two operating modes, namely uncalibrated mode or calibrated mode. The term calibration is related to the offset correction algorithm. The device starts up in uncalibrated mode. Most performance parameters will not be guaranteed in this mode. While the magnet moves, the device observes the magnetic input and adjusts for signal offsets. After a few periods the offset is calibrated and the device operates with its full performance.

To prevent unwanted switching, the changes below a certain value  $dB_{Limit}$  are not considered to switch the output.

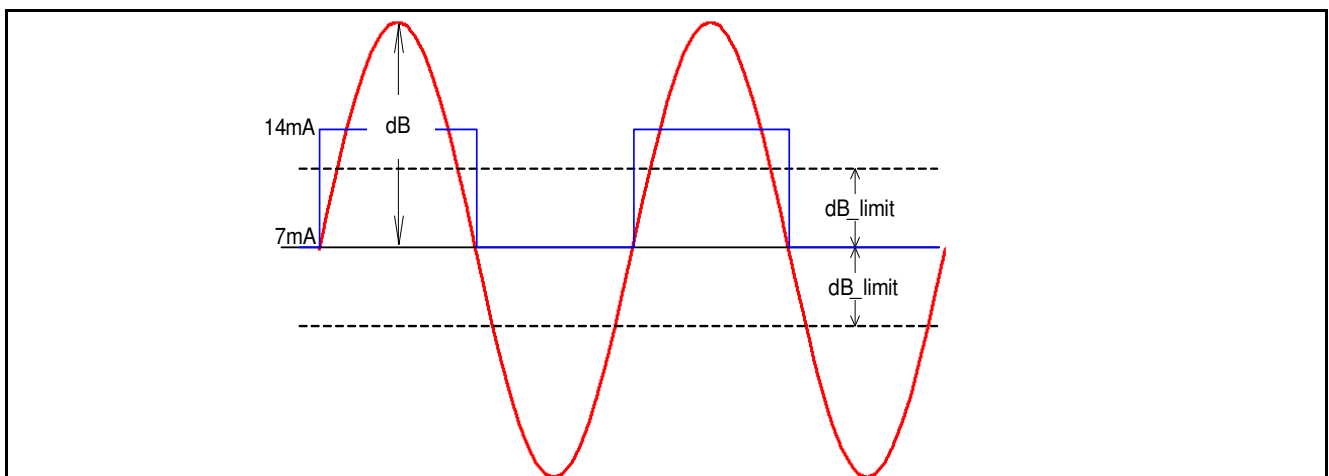

Figure 4 Differential amplitude and threshold  $dB_{Limit}$

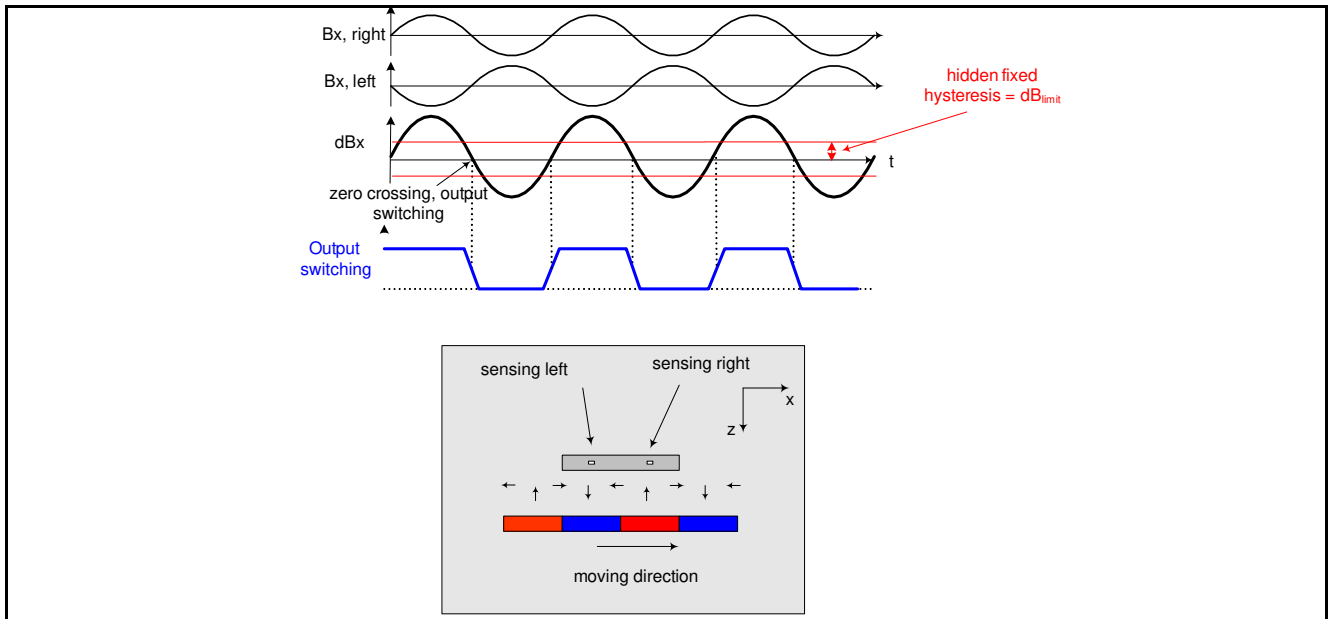

Figure 5 TLE5041plusC differential arrangement of sensing elements

### 2.4.1 Uncalibrated Mode

When the device is supplied after power down, the device is awake after power on time  $t_{POR}$ . The digital core immediately starts tracking the signal. In order to trigger a first edge, the magnetic signal has to exceed a threshold DNC (digital noise constant  $d_1$ ). Refer to Figure 6 where the first switching point is after the magnetic input has exceeded  $dB_{startup\_x}$ . The algorithm works in both directions, thus for rising and falling slopes.

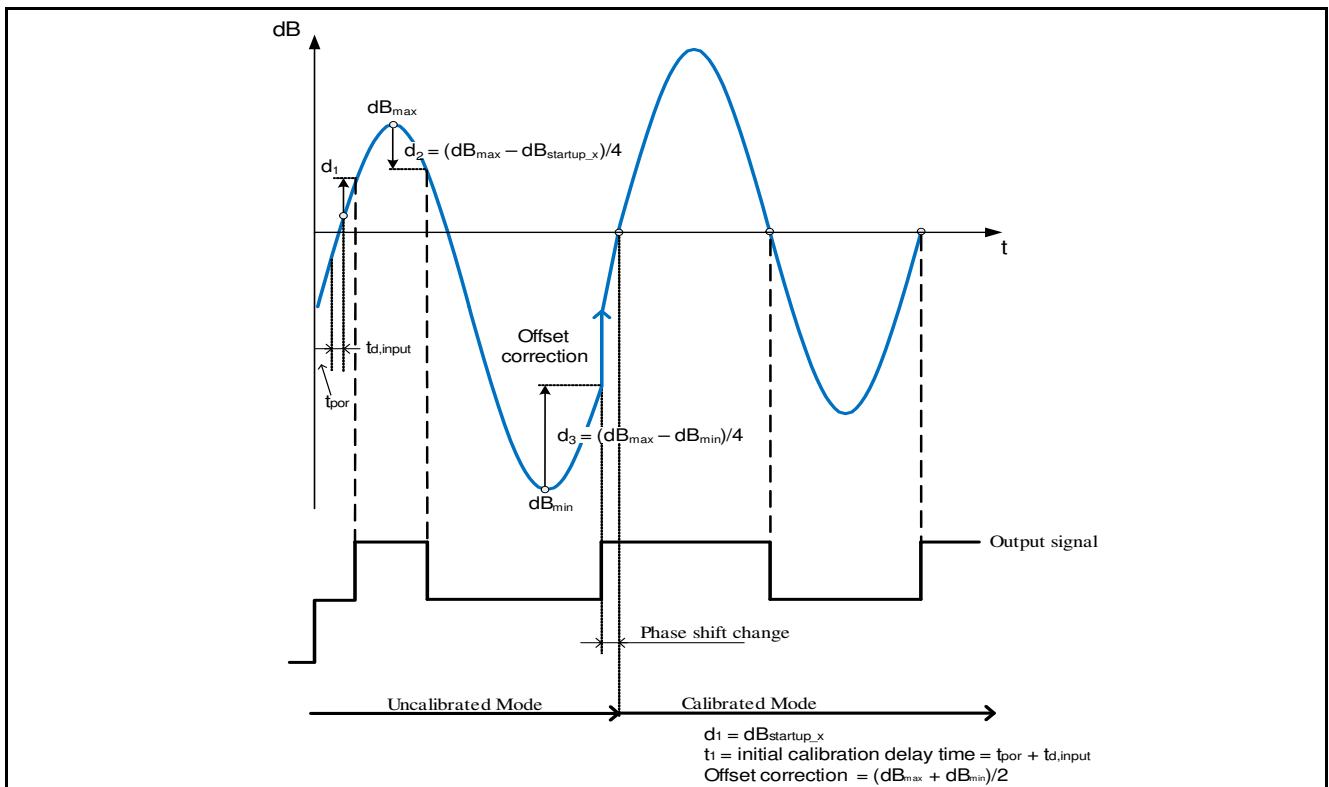

Figure 6 Offset calibration of TLE5041plusC

### 2.4.2 Calibrated Mode

In calibrated mode the output will switch at zero-crossing of the input signal. Oscillations of the Offset DAC are avoided by switching into a low-jitter mode. Signals below a defined threshold  $dB_{Limit}$  do not trigger the current interface to avoid unwanted output switching. Offset determination is done continuously in calibrated mode.

The phase shift between input and output signal is no longer determined by the ratio between digital noise constant and signal amplitude. Therefore a sudden change in the phase shift may occur during the transition from uncalibrated to calibrated mode.

### 2.4.3 Behavior at Magnetic Input Signals Slower than $f_{mag} < 1\text{Hz}$

Magnetic changes exceeding  $dB_{startup}$  can cause output switching of the TLE5041plusC even at  $f_{mag}$  significantly lower than 1 Hz. Depending on their amplitude edges slower than  $\Delta t_{startup}$  might be detected. If the digital noise constant ( $dB_{startup}$ ) is not exceeded before  $\Delta t_{startup}$  a new initial self-calibration is started. In other words  $dB_{startup}$  needs to be exceeded before  $\Delta t_{startup}$ . Output switching strongly depends on signal amplitude and initial phase.

### 2.4.4 Undervoltage behavior

The voltage supply comparator has an integrated hysteresis  $V_{hys}$  with the maximum value of the release level  $V_{rel} < 4.5\text{V}$ . This determines the minimum required supply voltage VDD of the chip. A minimum hysteresis  $V_{hys}$  of 0.7V is implemented thus avoiding a toggling of the output when the supply voltage VDD is modulated due to the additional voltage drop at  $R_M$  when switching from low to high current level and  $V_{DD} = 4.5\text{V}$  (designed for use with  $R_M \leq 75\Omega$ ).

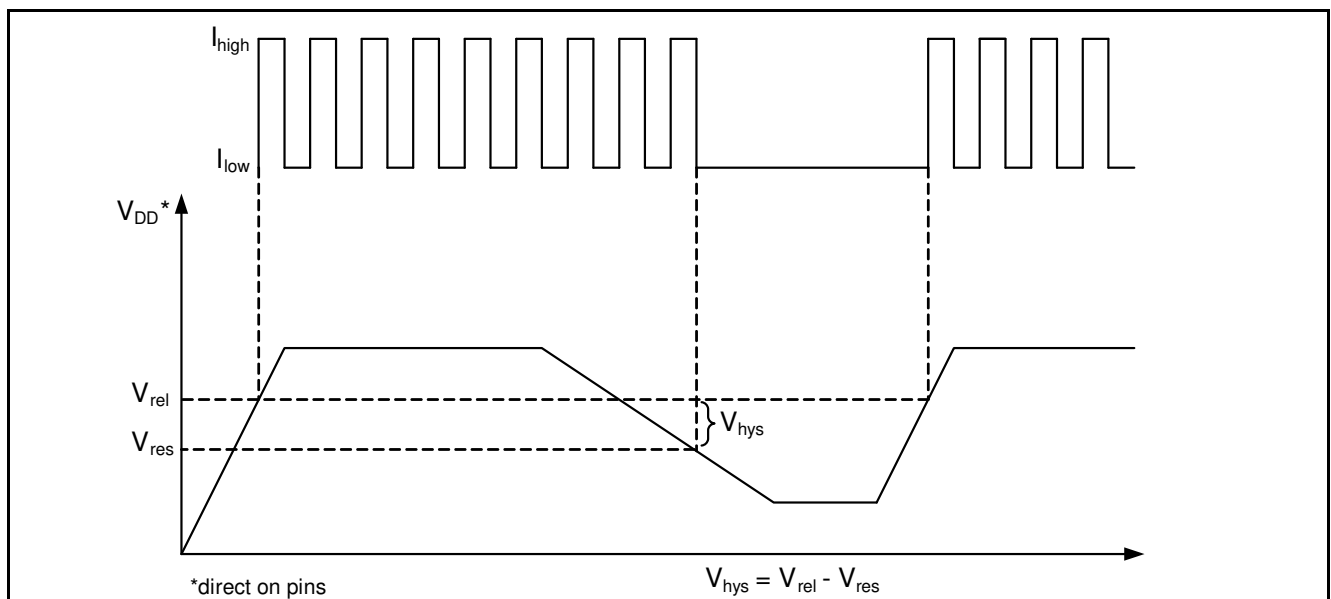

Figure 7 Undervoltage behavior

### 3 Specification

#### 3.1 Application Circuit

TLE5041plusC is designed to operate with a minimum amount of external components as shown in **Figure 9**. Refer to **Figure 9** for the recommended application circuit with reverse bias protection, over voltage protection and EMC capacitors. Component values depend on the application.

Inserting a  $10\ \Omega$  resistor in the  $V_{DD}$  path ( $R_1$ ) causes some additional voltage drop, limiting the maximum current through diode D2, adding to the overall circuits robustness. Increasing  $R_1$  further reduces supply voltage headroom.

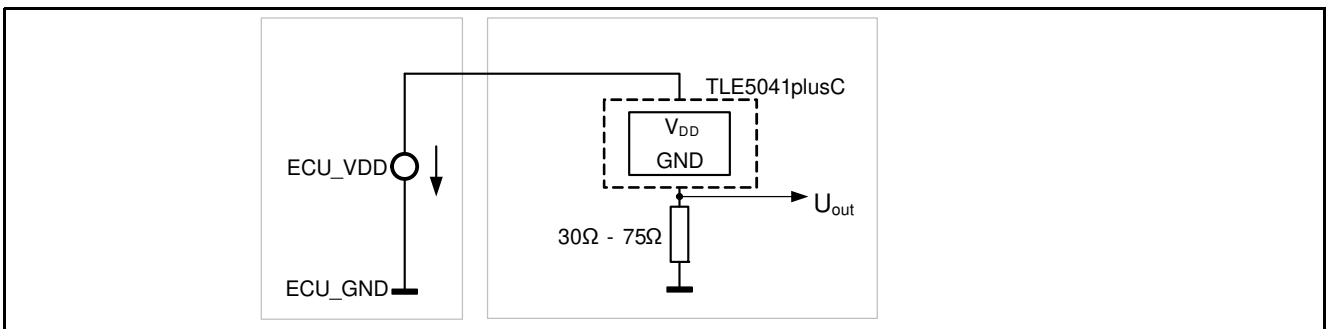

**Figure 8 Basic application circuit**

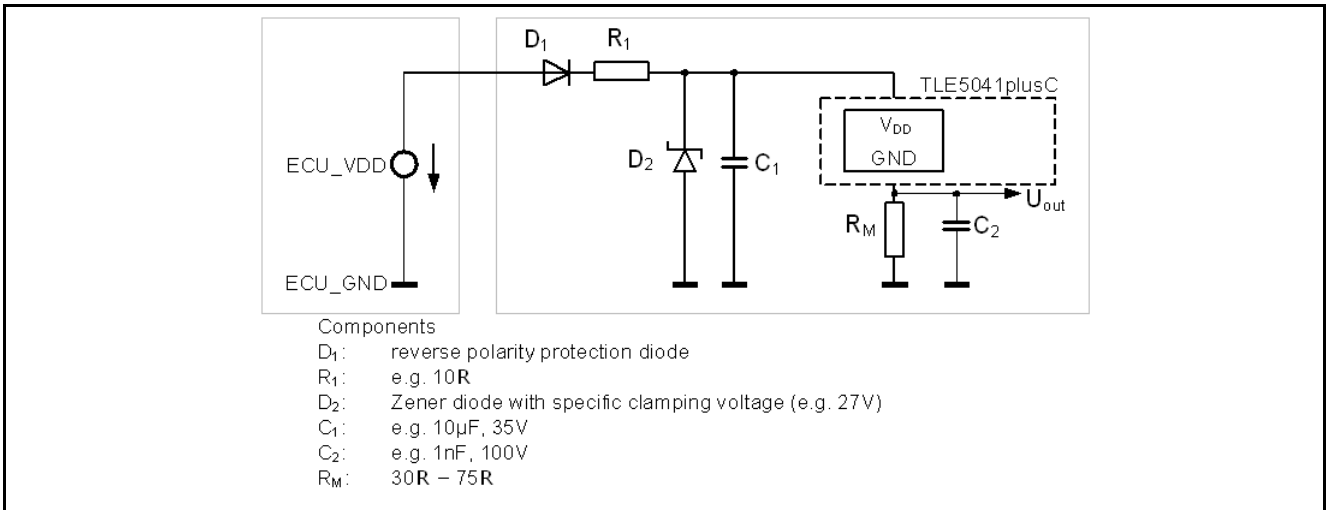

**Figure 9 Advanced application circuit including protection and EMC components**

### 3.2 Absolute Maximum Ratings

If not indicated otherwise, absolute maximum ratings are valid at  $T_j = -40^\circ\text{C}$  to  $150^\circ\text{C}$  and  $4.5\text{V} \leq V_{\text{DD}} \leq 20\text{V}$ .

**Table 2 Absolute maximum ratings**

Parameter	Symbol	Values			Unit	Note / Test Condition
		Min.	Typ.	Max.		
Supply voltage	$V_{\text{DD}}$	-0.3			V	$T_j < 80^\circ\text{C}$
				20	V	
				22	V	$t = 10 * 5 \text{ min.}$
				24	V	$t = 10 * 5 \text{ min.}$ , including voltage drop over $R_M \geq 30 \Omega$
				24	V	30 min. @ $T_j = 25 \pm 5^\circ\text{C}$
				27	V	$t \leq 400 \text{ ms}$ , including voltage drop over $R_M \geq 30 \Omega$
Reverse polarity voltage	$V_{\text{rev}}$	-22			V	with current limitation $I_{\text{rev}}$
Reverse polarity current	$I_{\text{rev}}$			200	mA	$t < 4 \text{ h}$ , external current limitation required
				300	mA	$t < 1 \text{ h}$ , external current limitation required
Junction temperature <sup>1)</sup>	$T_j$					
	either	-40		125	$^\circ\text{C}$	limited to 10000 h
	or	-40		150	$^\circ\text{C}$	limited to 5000 h
	or	-40		160	$^\circ\text{C}$	limited to 2500 h
	or	-40		170	$^\circ\text{C}$	limited to 500 h
	additional			190	$^\circ\text{C}$	$t = 4 \text{ h}$ , $V_{\text{DD}} < 16.5 \text{ V}$
	additional	-10		60	$^\circ\text{C}$	limited to 30000 h
Power-on cycles	$n_{\text{po}}$	500.000			times	
Passive life time <sup>1)</sup>	$LT_{\text{passive}}$	15			a	$T_j \leq 50^\circ\text{C}$ , $V_{\text{DD}} = 0 \text{ V}$
Maximum magnetic induction over lifetime <sup>2)</sup>	$B_x$	-300		300	mT	$T_j = 25^\circ\text{C}$
	$B_y$	-300		300	mT	$T_j = 25^\circ\text{C}$
	$B_z$	-1000		1000	mT	$T_j = 25^\circ\text{C}$

1) This life time statement is an anticipation based on extrapolation of Infineon qualification test results. The actual life time of a component depends on its form of application and type of use etc. and may deviate from such a statement. The life time statement shall in no event extend the agreed warranty period.

2) Conversion:  $B = \mu_0 * H$ ,  $\mu_0 = 4 * \pi * 10^{-7} \text{ mT/A}$

**Attention: Stresses above the max. values listed here may cause permanent damage to the device. Exposure to absolute maximum rating conditions for extended periods may affect device reliability. Maximum ratings are absolute ratings; exceeding only one of these values may cause irreversible damage to the integrated circuit.**

### 3.3 Operating Range

The following operating conditions must not be exceeded in order to ensure correct operation of the TLE5041plusC.

All parameters specified in the following sections refer to these operating conditions, unless otherwise noted.

**Table 3 Operating range**

Parameter	Symbol	Values			Unit	Note / Test Condition
		Min.	Typ.	Max.		
Supply voltage <sup>1)</sup>	$V_{DD}$	4.5		20	V	
Supply voltage modulation <sup>2)</sup>	$V_{AC}$			6	Vpp	$V_{DD} = 13\text{ V}, 0 < f_{mod} < 150\text{ kHz}$
Operating junction temperature	$T_j$					
	either	-40		125	°C	limited to 10000 h
	or	-40		150	°C	limited to 5000 h
	or	-40		160	°C	limited to 2500 h
	or	-40		170	°C	limited to 500 h
Junction temperature variation <sup>3) 4)</sup>	$T_{j\_var}$	-20		20	K/s	no unwanted or missing pulses
Magnetic induction amplitude at each GMR element <sup>4) 5)</sup>	$B_x$	-75		75	mT	$T_J = 25\text{ °C}$
Differential magnetic induction <sup>4) 5)</sup>	$dB_x$	-150		150	mT	$T_J = 25\text{ °C}$
Static differential magnetic pre-induction <sup>4)</sup>	$dB_{Xoffset}$	-2		2	mT	
Dynamic and static homogeneous external disturbance fields <sup>4)</sup>	$B_{ext\_XYZ}$	-2		2	mT	In calibrated mode. Same field at both probes, no unwanted pulses
Magnetic signal frequency <sup>4)</sup>	$f_{MAG}$	1		5000	Hz	

1) Directly at the sensor pins, not including the voltage drop at  $R_M$ .

2) Sinusoidal shape of supply voltage variation.

3) Junction temperature change homogenously distributed on the die, equal change at both iGMR sensing elements.

4) Not subject to production test, verified by design/characterisation.

5) Consider magnetic induction temperature coefficient of -0.18 %/K.



### 3.4 Characteristics

All parameters are related to the application test circuit shown in **Figure 10**.

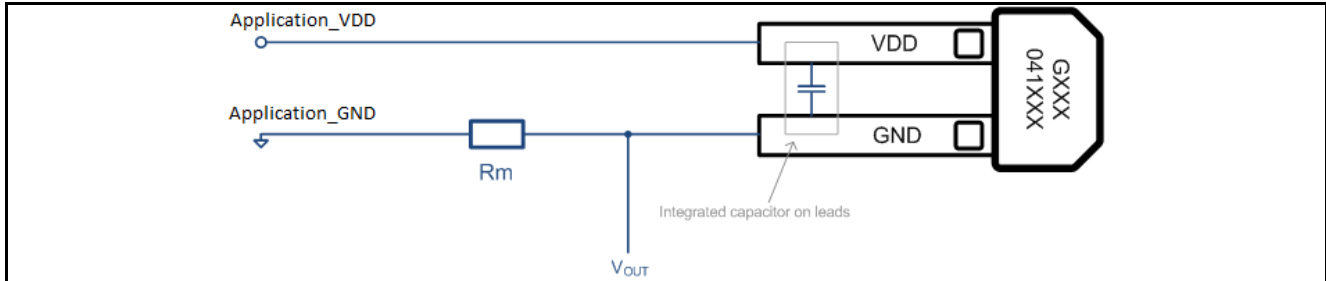

**Figure 10** Test circuit for the TLE5041plusC

#### 3.4.1 Electrical Parameters

The indicated electrical parameters apply over operating range, unless otherwise specified. The magnetic input is assumed sinusoidal with constant amplitude and offset. Typical values are at  $V_{DD} = 12V$  and  $T_A = 25^\circ C$ .

**Table 4** Electrical parameters

Parameter	Symbol	Values			Unit	Note / Test Condition
		Min.	Typ.	Max.		
Supply current - initial	$I_{INIT}$	5.9	7	8.4	mA	initial state is low
Supply current - output low	$I_{LOW}$	5.9	7	8.4	mA	
Supply current - output high	$I_{HIGH}$	11.8	14	16.8	mA	
Supply current ratio	$k_I$	1.9	2.1	2.3		$k_I = I_{HIGH} / I_{LOW}$
Output current slew rate <sup>1)</sup>	$SR_r, SR_f$	8		24	mA/ $\mu$ s	$R_M = 75 \Omega, R_M = 30 \Omega$
Line regulation <sup>2)</sup>	$S_L$			90	$\mu$ A/V	$dI_X / dV_{DD}$ , quasi static
Power on time <sup>2) 3)</sup>	$t_{POR}$			100	$\mu$ s	time required for stable $I_{INIT}$
Magnetic edges required for offset calibration <sup>2) 4)</sup>	$n_{start}$			4		5 <sup>th</sup> edge correct
Number of edges in uncalibrated mode <sup>2)</sup>	$n_{uncalib}$			4		
Number of edges suppressed <sup>2)</sup>	$n_{supressed}$			0		after power-on or reset
Magnetic edges required for first output pulse <sup>2) 5)</sup>	$n_{first\_pulse}$	1		2		after power-on or reset
Systematic phase error of output edges during start-up and uncalibrated mode <sup>2)</sup>	$\Phi_{uncalib}$	-90		+90	$^\circ$	Systematic phase error of "uncal" edge; $n^{th}$ vs. $n + 1^{th}$ edge (does not include random phase error)
Phase shift change during transition from uncalibrated to calibrated mode <sup>2)</sup>	$\Delta\Phi_{switch}$	-45 -90		+45 +90	$^\circ$	$dB_X > 4 \times dB_{Startup\_X}$ $dB_X < 4 \times dB_{Startup\_X}$
Max. permissible change of signal offset with time <sup>2)6)</sup>	$d_{BX\_Offset}$			10	%	Within one signal period, assumig sinusoidal input signal
Initial calibration delay time <sup>2)7)</sup>	$t_{d, input}$		120	300	$\mu$ s	min-max detection starts after this time, additional to $t_{POR}$
Switching delay time <sup>2)8)</sup>	$t_D$			100	$\mu$ s	$dB_X \geq 1mT$

**Table 4 Electrical parameters**

Parameter	Symbol	Values			Unit	Note / Test Condition
		Min.	Typ.	Max.		
Duty cycle <sup>2)</sup>	DC	40	50	60	%	$dB_X \geq 2 \text{ mT}$ , $B_{\text{ext\_XYZ}} = 0 \text{ mT}$ , differential offset jumps are not considered <sup>9)</sup>
Period Jitter <sup>2) 10)</sup>	$S_{\text{jit1}}$			$\pm 0.3$	%	$\pm 3 \sigma$ value of period T $-10 \text{ }^\circ\text{C} \leq T_j \leq 80 \text{ }^\circ\text{C}$ $dB_X \geq 1 \text{ mT}$ $100 \text{ Hz} \leq f_{\text{MAG}} \leq 1000 \text{ Hz}$ , $B_{\text{ext\_XYZ}} = 0 \text{ mT}$ , valid in the operating area described in <a href="#">Chapter 3.4.2.1</a>
	$S_{\text{jit2}}$			$\pm 2$	%	$\pm 3 \sigma$ value of period T $-40 \text{ }^\circ\text{C} \leq T_j \leq 150 \text{ }^\circ\text{C}$ $dB_X \geq 1 \text{ mT}$ $1 \text{ Hz} \leq f_{\text{MAG}} \leq 2500 \text{ Hz}$ , $B_{\text{ext\_XYZ}}^{11)} \leq 0.15 \text{ mT}$
	$S_{\text{jit3}}$			$\pm 3$	%	$\pm 3 \sigma$ value of period T $-40 \text{ }^\circ\text{C} \leq T_j < 170 \text{ }^\circ\text{C}$ $dB_X \geq 1 \text{ mT}$ $1 \text{ Hz} \leq f_{\text{MAG}} \leq 5000 \text{ Hz}$ , $B_{\text{ext\_XYZ}}^{11)} \leq 0.15 \text{ mT}$
Time allowed for edge to exceed $dB_{X\_Startup}$ <sup>2)</sup>				590	ms	
Watchdog reset time <sup>2)</sup>	$t_{\text{WD\_reset}}$	590		848	ms	

- 1) Refer to [Figure 11](#)
- 2) Not subject to production test, verified by design/characterisation.
- 3)  $V_{\text{DD}} \geq 4.5\text{V}$ .
- 4) One magnetic edge is defined as a monotonic signal change of more than 0.6 mT.
- 5) A loss of edges may occur at high frequencies.
- 6) Percentage of amplitude
- 7) Occurrence of initial calibration delay time  $t_{\text{d, input}}$ : if there is no input signal change (e.g. at vehicle halt) a new initial calibration is triggered each  $t_{\text{WD\_reset}}$  according to [Chapter 2.4.3](#). This calibration has a duration of  $t_{\text{d, input}}$ . During this calibration time no input signal change is detected.
- 8) Internal signal propagation delay time between magnetic input signal and electrical output signal in calibrated mode.
- 9) During fast offset alterations, due to the calibration algorithm, exceeding the specified duty cycle is permitted for short time periods.
- 10) Refer to [Figure 12](#)
- 11) Verified by design

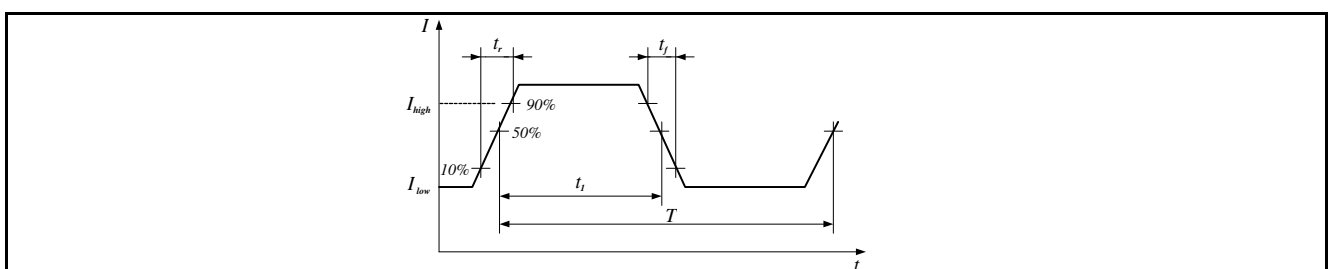

**Figure 11 Slew Rate definition**

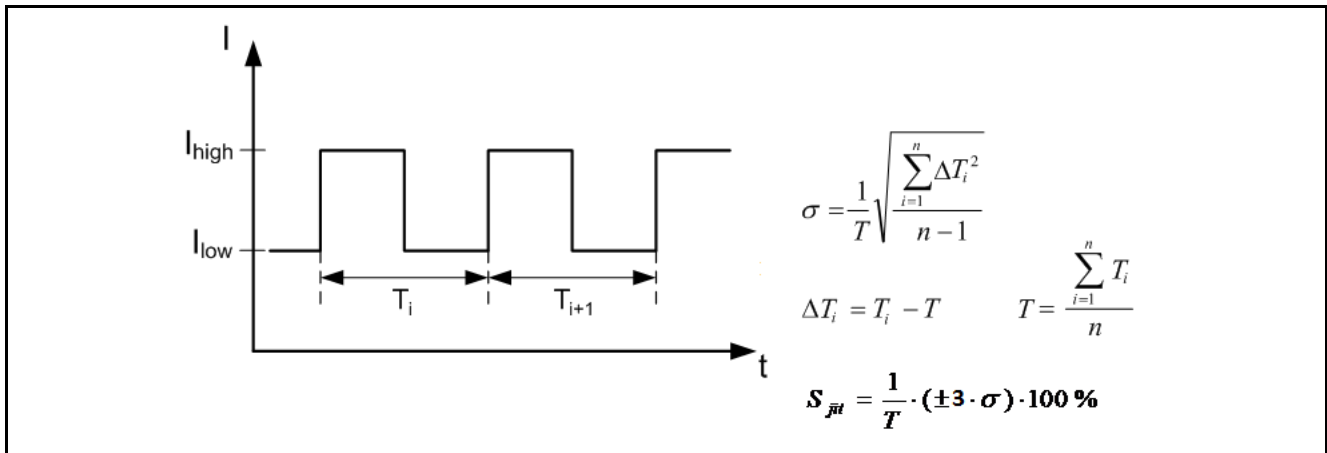

Figure 12 Period jitter definition is valid for measurement on rising-to-rising or falling-to-falling edge

### 3.4.2 Magnetic Input Characteristics

All magnetic input values specified at constant sinusoidal amplitude and constant offset over operating range, unless otherwise specified. Magnetic values are referred to the location at the silicon surface. Typical values are related to  $V_{DD} = 12V$  and  $T_A = 25^\circ C$ .

Table 5 Magnetic input values

Parameter	Symbol	Values			Unit	Notes
		min.	typ.	max.		
Threshold limit <sup>1) 2) 3)</sup>	$dB_{Limit\_X}$	0.1	0.18	0.3	mT	$1 \text{ Hz} < f_{MAG} < 5000 \text{ Hz}$ , $B_Y \leq 0.15 \text{ mT}$ , $B_{ext\_XYZ} = 0 \text{ mT}$
Start-up threshold peak to peak value <sup>3)</sup> <sup>4)</sup>	$dB_{Startup\_X}$	0.2	0.36	0.6	mT	$1 \text{ Hz} < f_{MAG} < 5000 \text{ Hz}$ , $B_Y \leq 0.15 \text{ mT}$ , $B_{ext\_XYZ} = 0 \text{ mT}$
Internal offset drift <sup>3)</sup>	$dB_{X\_Drift}$	0		0.1	mT	

1) Refer to [Figure 6 “Offset calibration of TLE5041plusC” on Page 11](#).  $dB_{Limit\_X}$  is a 99% criteria, calculated out of measured sensitivity.

2) Threshold limit  $dB_{Limit\_X}$  is increased by 25% under influence of an in-plane magnetic induction perpendicular to the sensitive direction (refer to [Chapter 3.3 “Operating Range” on Page 15](#) of  $B_{ext\_XYZ}$ ).

**Note:** In typical encoder wheel applications, at large air gaps where  $dB_X$  is as low as  $dB_{Limit\_X}$ , the in-plane magnetic induction perpendicular to the sensitive direction  $B_Y$  is smaller than 0.15mT.

3) Not subject to production test, verified by design/characterisation

4)  $dB_{Startup\_X}$  is the minimum DNC at start-up.

### 3.4.2.1 Operating area for Period Jitter $S_{jit1}$

It has to be ensured that the operating location of the sensor is selected in accordance to  $B_{X\_Area}$  and  $B_{Y\_Area}$  referring to [Table 6](#). The operating location is defined by air gap and displacement in Y direction. Therefore the project specific encoder wheel parameters have to be characterized.

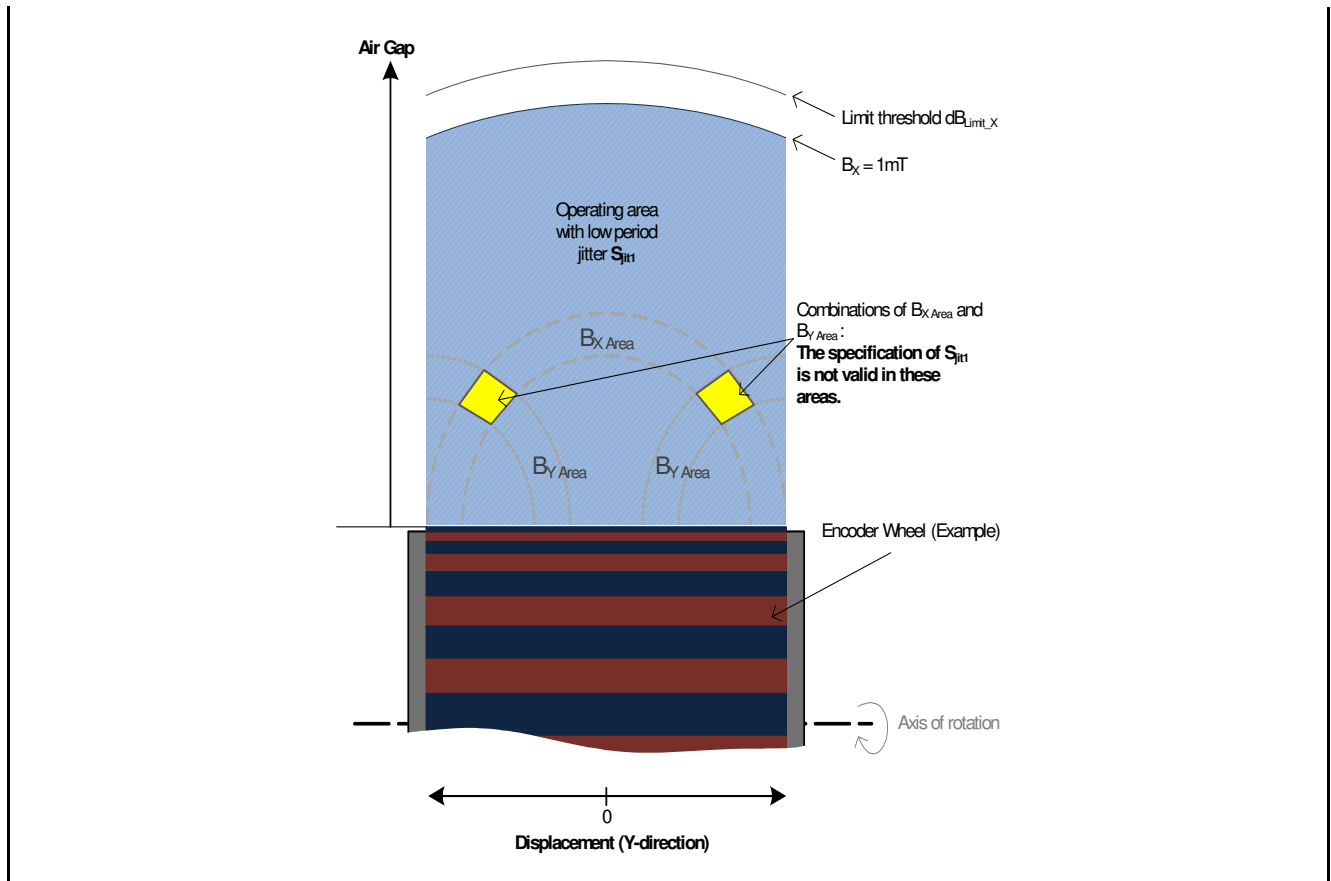

**Figure 13** Operating area for period jitter  $S_{jit1}$

Marked areas are defined by a combination of  $B_Y$  and  $B_X$  field components. [Table 6](#) shows field amplitudes (field offsets are not considered) related to these areas.

In most cases the areas marked in figure [Figure 13](#) are at low air gaps, close to the pole wheel.

**Table 6** Magnetic induction area where period jitter exceeds  $S_{jit1}$

Parameter	Symbol	Values		Unit	Notes
		min.	max.		
Magnetic induction area in X-direction <sup>1)</sup>	$B_{X\_Area}$	2.9	10	mT	in combination with $B_{Y\_Area}$
Magnetic induction area in Y-direction <sup>1)</sup>	$B_{Y\_Area}$	0.7	2.9	mT	in combination with $B_{X\_Area}$

1) Not subject to production test. Verified by characterisation.

The sequence to find the areas marked in [Figure 13](#) is:

- The encoder wheel magnetic field shall be characterised (measurement of  $B_X$  and  $B_Y$  at the sensor location).
- Is the amplitude of the magnetic induction  $B_X$  between the minimum and maximum value of  $B_{X\_Area}$ ?
  - If the answer is NO: no further action required
  - If the answer is YES: For low jitter  $S_{jit1}$  the magnetic field at the sensor location shall not have a value between the minimum and maximum value of  $B_{Y\_Area}$

*Note: This information applies especially to narrow pole wheels. Depending on the pole wheel these areas are at a magnetic air gap of 0.8mm to 2.8mm. At a specific air gap the mounting tolerance in Y-direction can be between +/- 0.5mm to +/-2mm. This effect is usually observed when using narrow pole wheels, it is recommended to investigate the magnetic field of every pole wheel used. Air gap and tolerance in Y-direction are typical application values mentioned here are for information only, without specification character. For further information and support please contact Infineon.*

### 3.4.3 Typical Diagrams (measured performance)

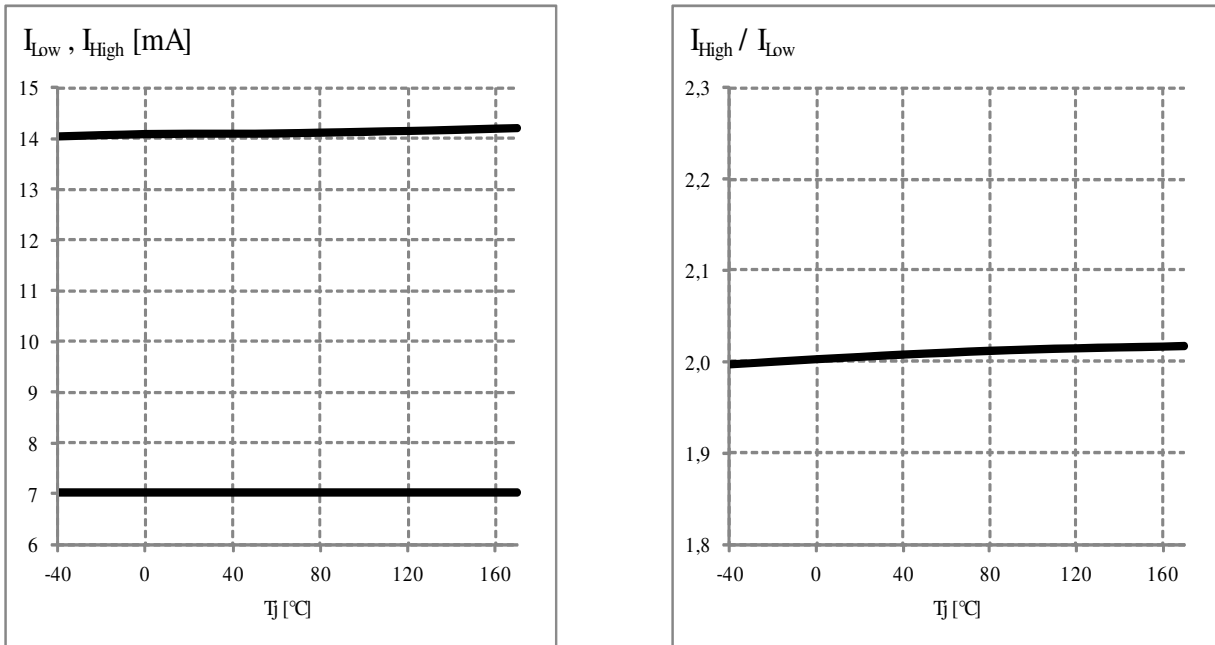

Figure 14 Supply Current =  $f(T)$  (left), Supply Current Ratio  $I_{High} / I_{Low} = f(T)$  (right)

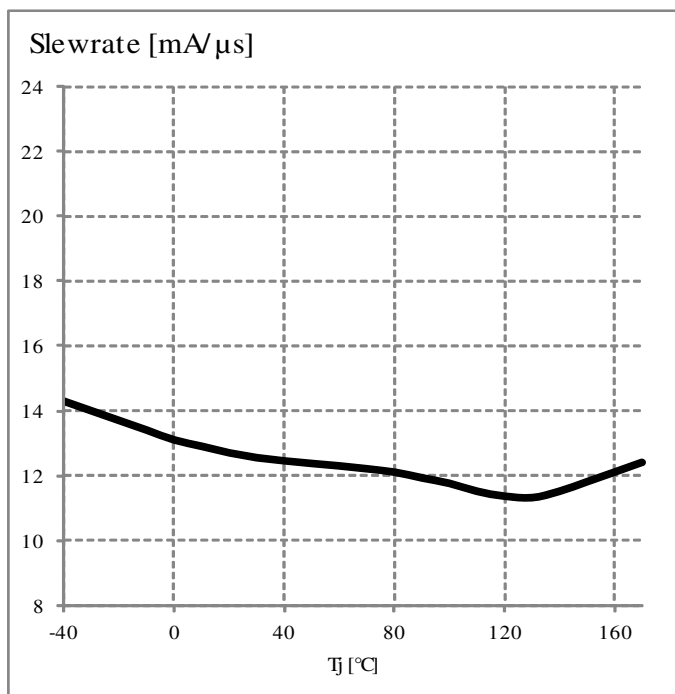

Figure 15 Slew Rate =  $f(T)$ ,  $R_M = 75 \Omega$

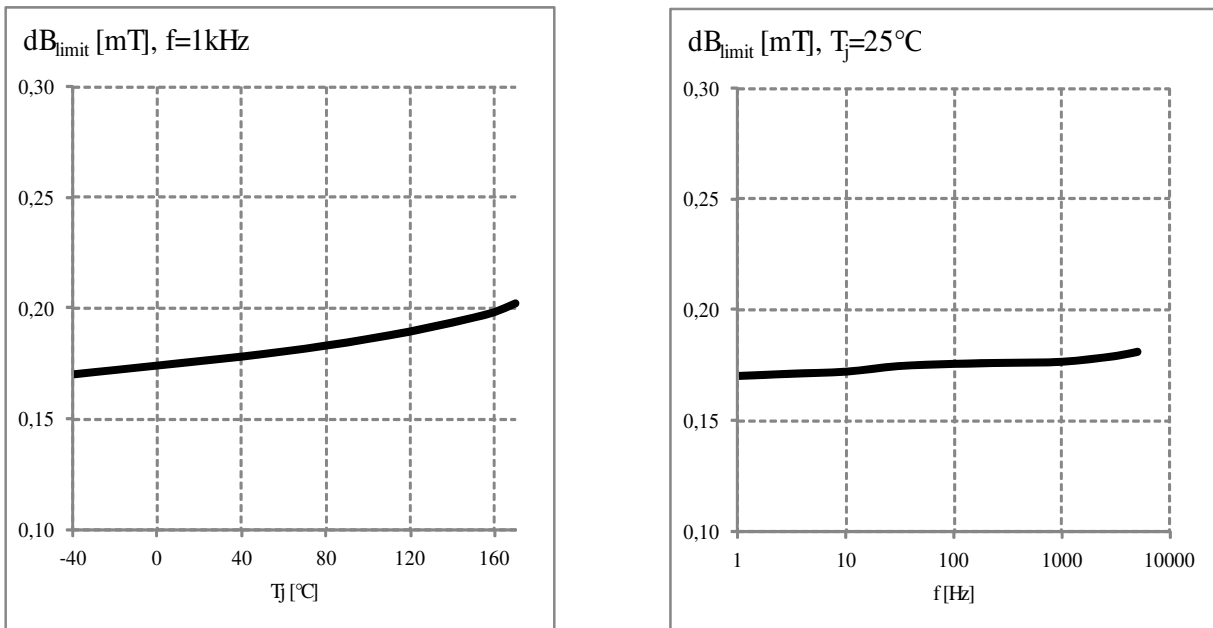

Figure 16 Magnetic Threshold  $dB_{Limit} = f(T)$  (left), Magnetic Threshold  $dB_{Limit} = f(f)$  (right)

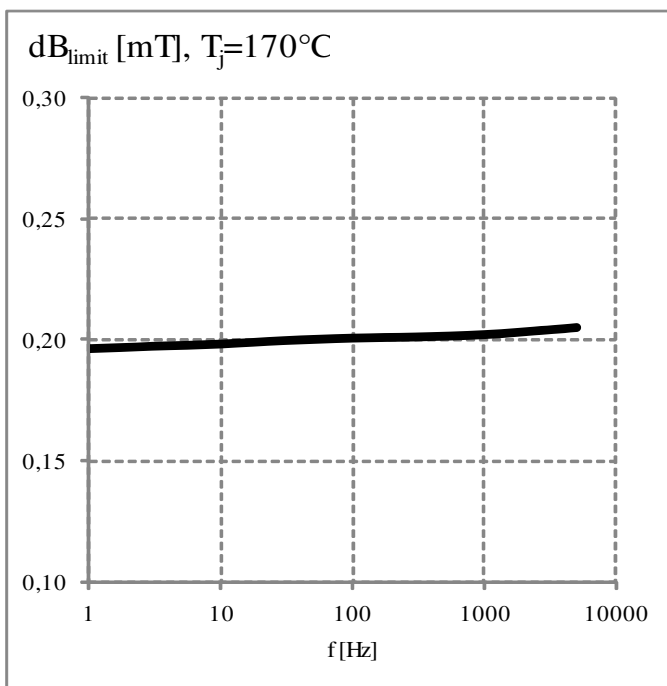

Figure 17 Magnetic Threshold  $dB_{Limit} = f(f)$



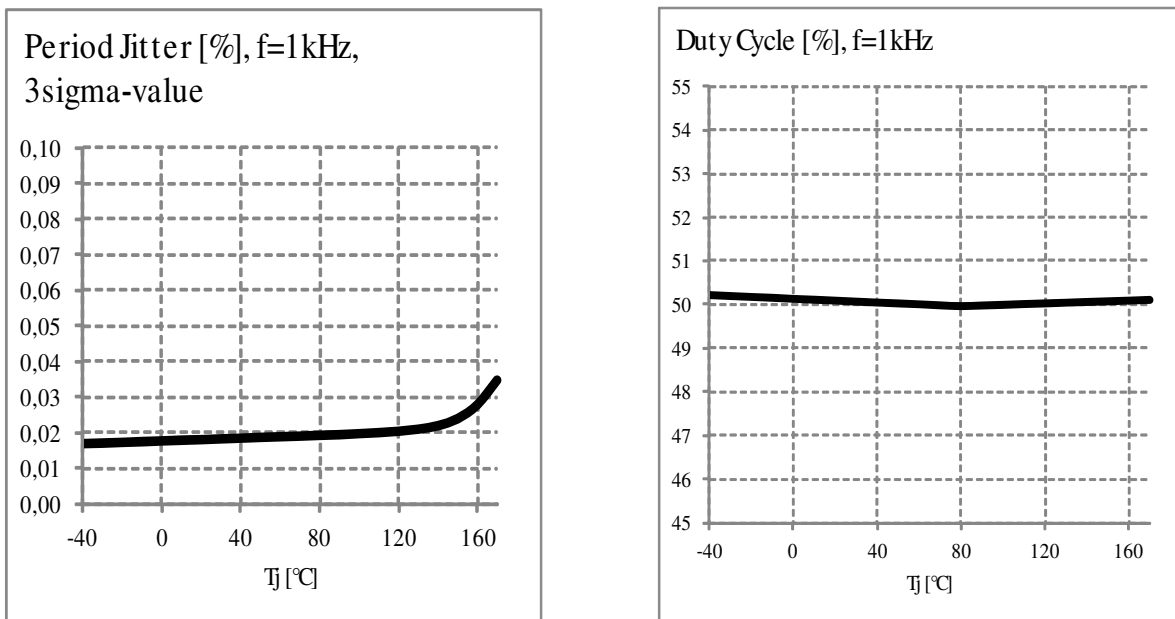

Figure 18 Period Jitter =  $f(T)$  at  $dB_x = 2$  mT (left) , Duty Cycle =  $f(T)$  at  $dB_x = 2$  mT (right)

### 3.4.4 Electrostatic discharge protection

Characterized according to Human Body Model (HBM) test in compliance with EIA/JESD22-A114-B HBM (covers MIL STD 883D)

**Table 7 ESD protection**

Parameter	Symbol	Values		Unit	Notes
		min.	max.		
ESD voltage	$V_{HBM}$		$\pm 12$	kV	Method AEC-Q100 (1.5 k $\Omega$ , 100 pF)
ESD voltage	$V_{SDM}$		$\pm 2$	kV	Method ANSI/ESD SP5.3.2-2008

### 3.5 Electro Magnetic Compatibility (EMC)

The device is characterized according to the IC level EMC requirements described in the “Generic IC EMC Test Specification” Version 1.2 from 2007<sup>1)</sup>.

Additionally component level EMC characterizations according to ISO 7637-2:2011, ISO 7637-3:2007 and ISO 16750-2:2010 regarding pulse immunity and CISPR 25 (2009-01) Ed. 3.0 regarding conducted emissions are performed.

*Note:* Characterization of electromagnetic compatibility is carried out on sample base. Not all specification parameters can be monitored during EMC exposure. Only functional parameters, e.g., switching current and duty cycle have been monitored.

**Figure 19** outlines all needed external components to operate the DUT under application conditions. The (additional) outlined components can effect the final EMC result. They are treated as inherent part of the DUT during component level EMC characterizations.

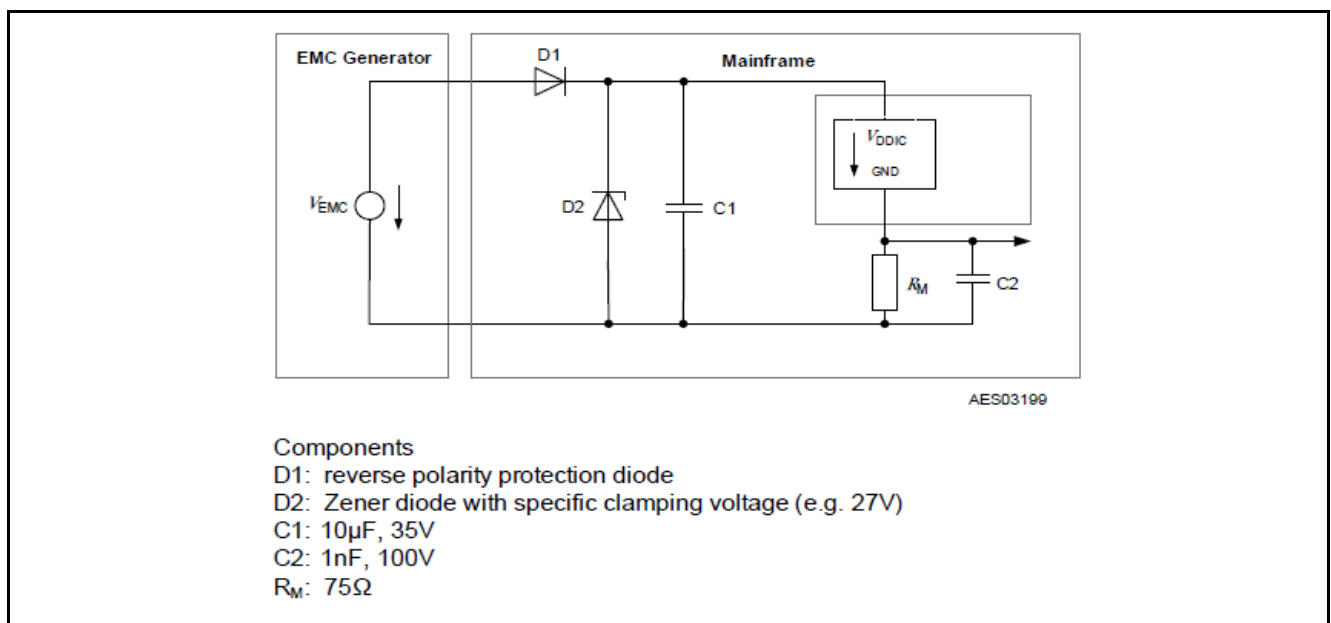

**Figure 19 EMC test circuit for the TLE5041plusC**

1) The document is available online at <http://www.zvei.org/Verband/Publikationen/Seiten/Generic-IC-EMCTest-Specification-english.aspx>.

### 3.5.1 ISO 7637-2:2011 and ISO 16750-2:2010

Refer to EMC test circuit;  $dB_x = 2mT$  (amplitude of sinus signal);  $V_{DD} = 13.5V$ ,  $f_{MAG} = 100Hz$ ;  $T = 25^\circ C$

**Table 8 Conducted pulses along supply lines**

Test Pulse	Symbol	Level/Typ	Status
TP1 <sup>1)</sup>	$V_{EMC}$	IV / -150V	C / A (after stress)
TP2a <sup>1)</sup>		IV / 112V	C
TP2b <sup>2)</sup>		- / 10V	C
TP3a <sup>1)</sup>		IV / -220V	A
TP3b <sup>1)</sup>		IV / 150V	A
TP4 <sup>3)</sup>		IV / -7V	C
TP5a <sup>3)</sup>		IV / 86.5V	C
TP5b <sup>4)</sup>		$Us^* = 28.5V$	C

1) according to ISO 7637-2:2011

2) according to ISO 7637-2:2004

3) according to ISO 16750-2:2010

4) According to ISO 16750-2:2010. A central load dump of 42V is used.  $Us = 42V - 13.5V$ .

### 3.5.2 ISO 7637-3:2007

Refer to EMC test circuit;  $dB_x = 2mT$  (amplitude of sinus signal);  $V_{DD} = 13.5V$ ,  $f_{MAG} = 100Hz$ ;  $T = 25^\circ C$

**Table 9 Pulses by capacitive coupling on signal lines**

Test Pulse	Symbol	Level/Typ	Status
TP3a	$V_{EMC}$	IV / -220 V	A
TP3b		IV / 150V	A

### 3.5.3 ISO 11452-3:2004

Refer to EMC test circuit;  $dB_x = 2mT$  (amplitude of sinus signal);  $V_{DD} = 13.5V$ ,  $f_{MAG} = 100Hz$ ;  $T = 25^\circ C$

**Table 10 Radiated immunity**

Parameter	Symbol	Level/Typ	Remark
EMC field strength	$E_{TEM-Cell}$	IV / 250 V/m	AM (80%, 1kHz)

## 4 Package Information

Pure tin plating (green lead plating) is used with the plastic single small outline package PG-SSO-2-53. The product complies to restrictions of hazardous substances (RoHS) when marked with the letter G in front or after the date code. Additionally it shows a data matrix on the back side of the package.

### 4.1 Package Parameters

**Table 11 Package parameters**

Parameter	Symbol	Limit Values			Unit	Notes
		min.	typ.	max.		
Thermal Resistance	$R_{thJA}$			190	K/W	Junction-to-Air <sup>1)</sup>
Lead Frame		CuSn1CrNiTi				material K62 (UNS:C18090)
Lead pull out Force	$F_{PO}$	10			N	for each lead <sup>2)</sup>

1) According to Jedec JESD51-7

2) according to IEC 60068-2-21 (fifth edition 1999-1)

### 4.2 Bending for assembly

By following our package handling and assembly recommendation remarks for Sensor-packages the sensor terminals can be bent without causing incipient cracks influencing the sensor element function. Please contact your local Infineon application support.

### 4.3 Package surface to silicon

The distance from the package surface to the surface of the silicon chip  $d = 0.3 \text{ mm} \pm 0.08 \text{ mm}$ .

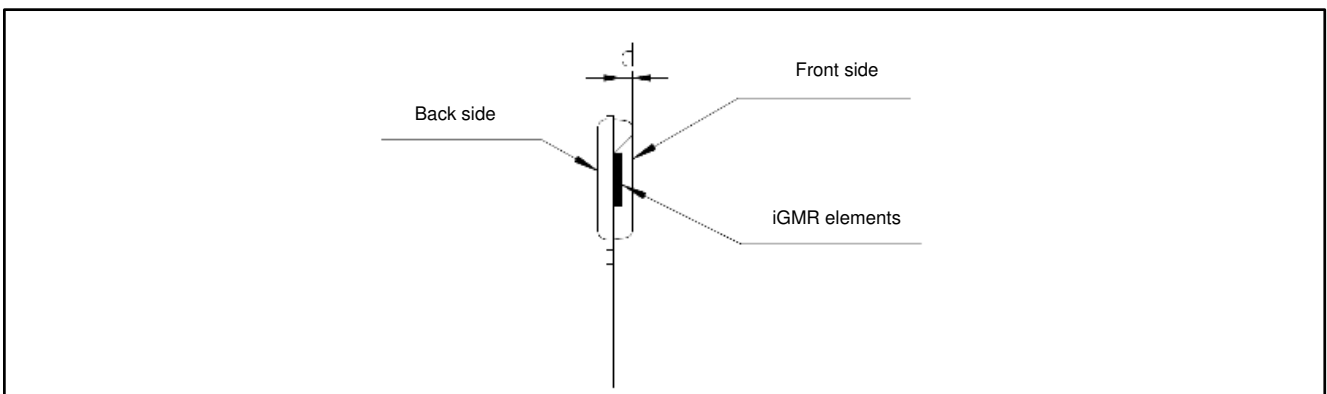

**Figure 20 Distance from package surface to silicon (=sensing element)**

### 4.4 Package Outline

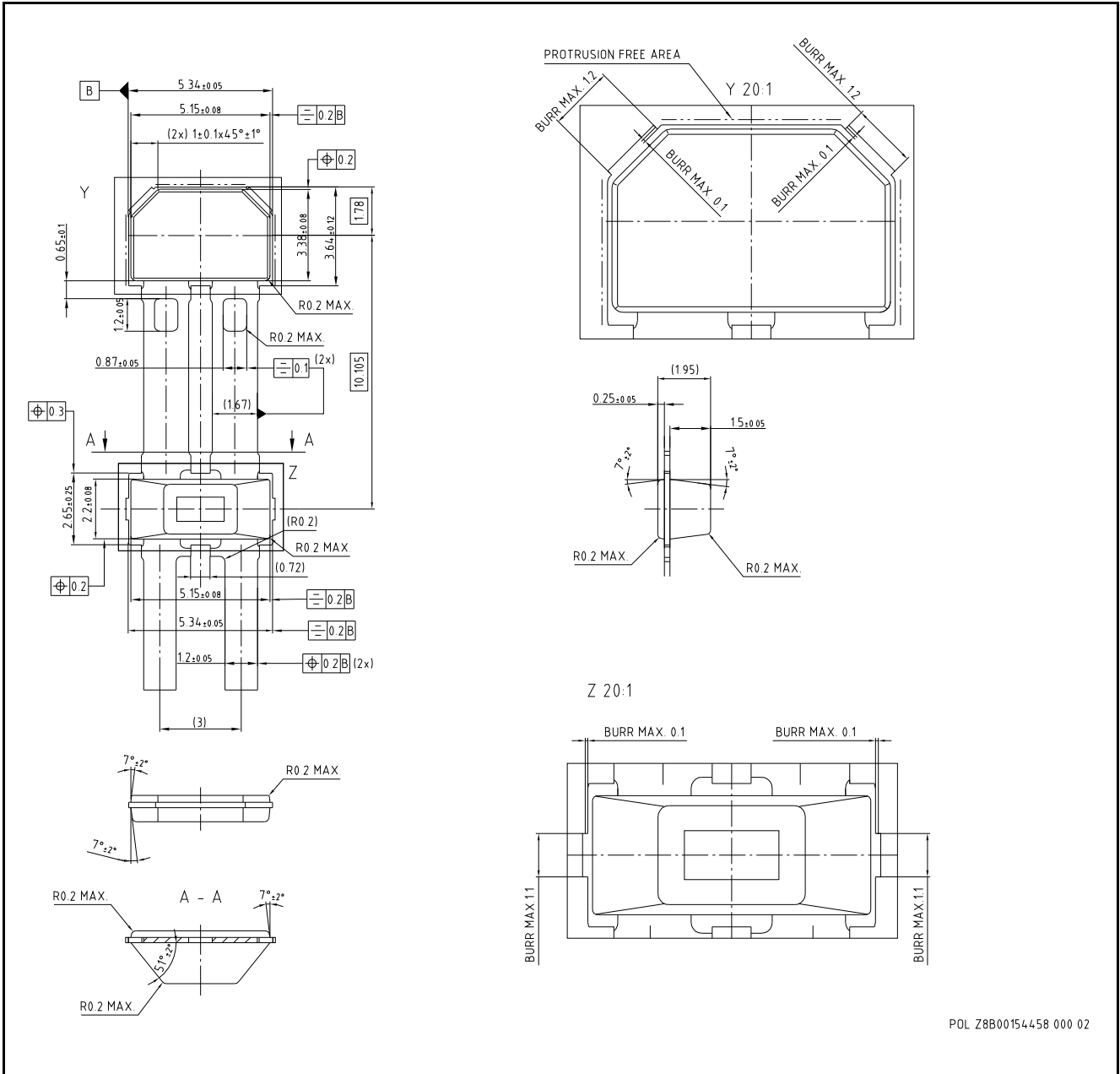

Figure 21 Package dimensions



### 4.6 Marking

#### Front side marking

The TLE5041plusC is delivered in Ammopack as described below.

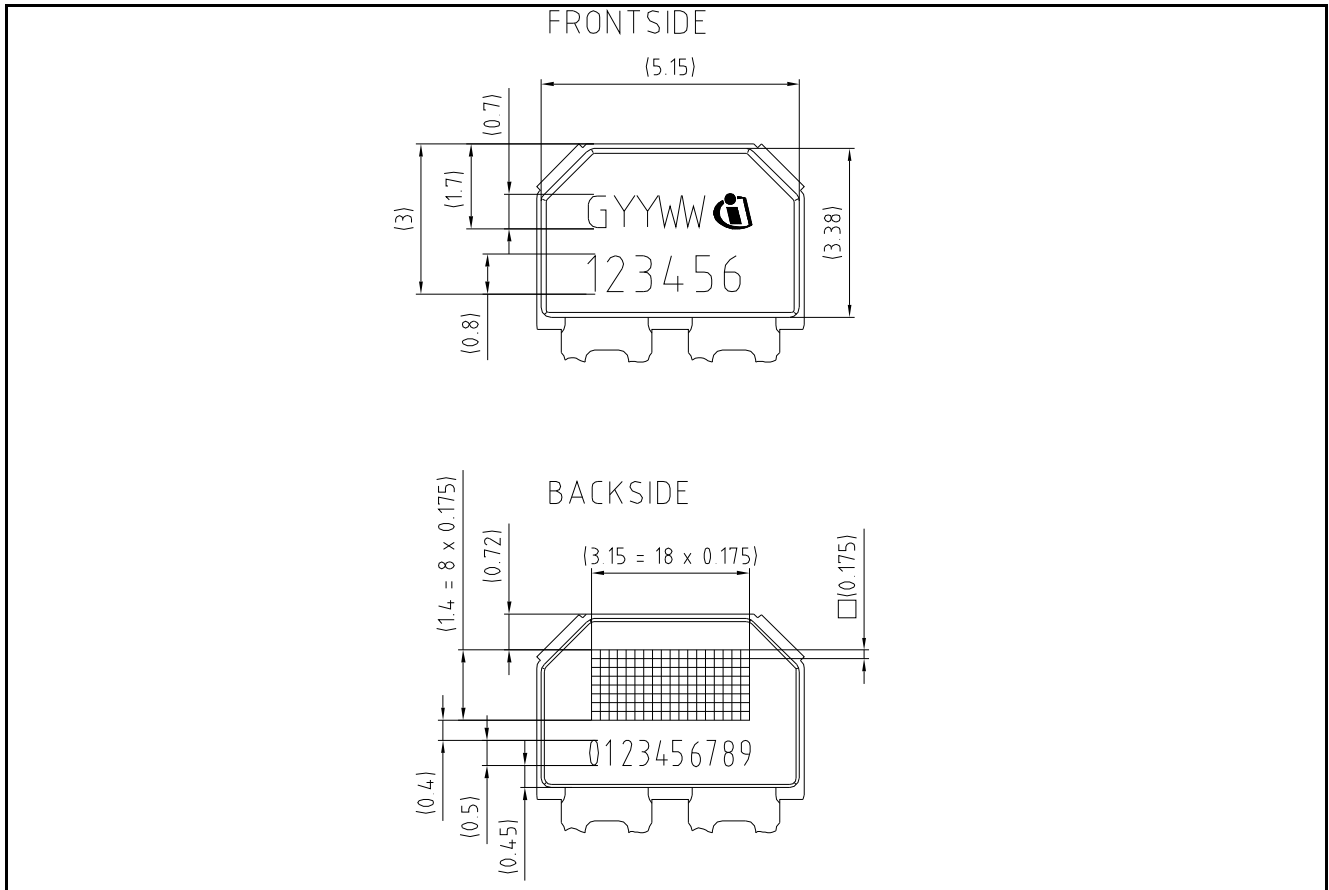

Figure 23 Packing dimensions in mm

Position	Marking	Description
1st Line	GYYWW	G: green package YY: production year WW: production week
2nd Line	123456	Marking

#### Backside marking

Position	Marking	Description
1st Line	xxxxxxx	Data Matrix Code
2nd Line	0123456789	Data Matrix Code



[www.infineon.com](http://www.infineon.com)

Published by Infineon Technologies AG