

	FORCE(gf)	KNOB COLOUR	OPERATING LIFE WITH LOAD	SPRING PLATE
H	100±30	WHITE	100,000 Cycles	1
0	130±30	GREY		
1	160±30	BLACK		
3	250±50	IVORY/GREEN	50,000 Cycles	1
4	300±50	BLACK	50,000 Cycles	2
	380±50			
5	500±100	GREY		

L	
A	4.3
B	5

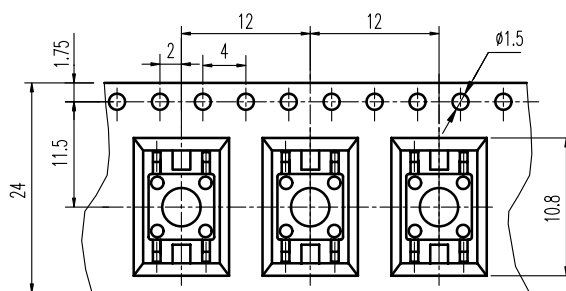
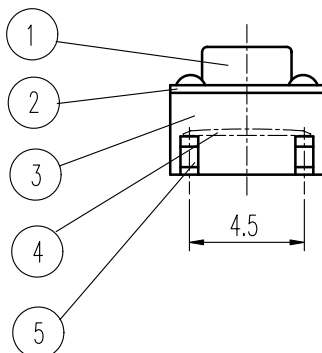
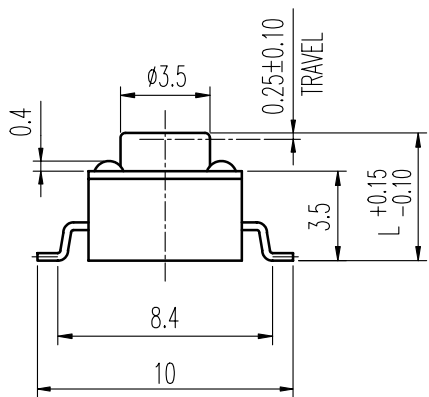

PACKAGE : 1,250 SWITCHES PER REEL

Ⓕ

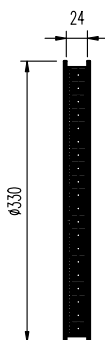
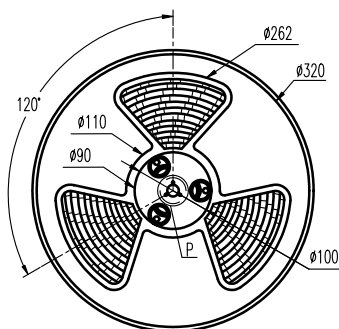
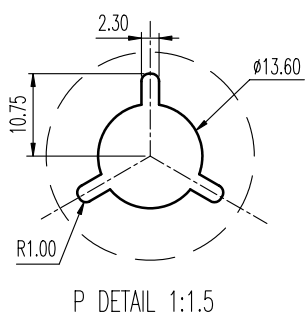

### 规格 Specifications

额定负荷 Rdtngs	DC 12_V_50_mA
接触阻抗 Contact Resistance	100_mΩ Max.
绝缘阻抗 Insulation Resistance	DC 100_V_60_Sec. 100_MΩ Min.
抗电强度 Dielectric Voltage	AC 250_V(50~60HZ) 60_Sec.
操作力 Operating Force	见上表
负荷寿命 Operating Life With Load	见上表



示意图 SCHEMATIC

安装孔 PIERCING PLAN

序号 NO.	零件 PART	材料 MATERIAL	数量 QTY	备注 REMARKS
5	端子 TERMINAL	C2680R	4	Ag PLATED
4	弹片 SPRING PLATE	C5210R	见上表	Ag CLAD
3	胶壳 HOUSING	PA	1	BLACK
2	盖片 COVER	SPCC	1	Ni PLATED
1	胶柄 KNOB	PA	1	

标号 REV	内容 DESCRIPTION	签名 SIGN.	日期 DATE
A07	PACKAGE : 1000 SWITCHES PER REEL 变更为 1,250 SWITCHES PER REEL, 见标注Ⓕ	张渠江	2010-7-13
A06	盖片材料由SPTe变更为SPCC 备注项由NATURAL 变更为N PLATED, 见标注Ⓖ	张渠江	2009-11-3
A05	POLY FILM → SPTe 见标注Ⓖ	鲁腾	2007-5-18
A04	PACKAGE : 700 SWITCHES PER REEL PACKAGE : 1000 SWITCHES PER REEL / 取消共用柄长 见Ⓒ	王光云	2006-10-16
A03	增加寿命次数和弹片数量见上表Ⓖ	杨蝶	2006-10-13
A02	修改见Ⓕ	饶品旺	2005-11-30
标号 REV	内容 DESCRIPTION	签名 SIGN.	日期 DATE

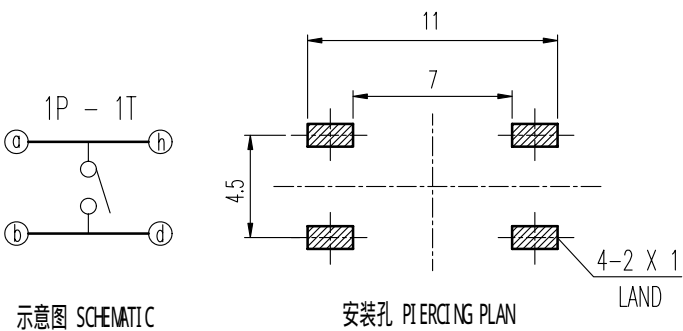
DWG NO. ITEM2573

TOLERANCES UNLESS OTHERWISE SPEC.		TITLE	TACT SWITCH		ITEM NO	RS-014R05__SMA RT	
UNDER 1	± 0.10	DRAWN	张渠江	2010-7-13	VERSION	A07	PAGE 1 OF 1
1 - 10	± 0.30	REVIEWED	王光云	2010-7-13	SCALE		UNIT mm
OVER 10	± 0.50	APPROVED	马建和	2010-7-13	PROJECTION		

COMAX

高铭电子(惠州)有限公司  
Comax Electronics(Huizhou)Co.,Ltd.