



CERAMIC

# Power Splitter/Combiner

## SCG-2-592+

2 Way-0° 50Ω 3800 to 5900 MHz

### FEATURES

- Isolation resistor, external 100 ohms
- Low insertion loss, 0.8 dB typ.
- Excellent amplitude unbalance, 0.1 dB typ.
- Excellent phase unbalance, 1.5 deg. typ.
- High isolation, 15 dB typ.
- ESD non-sensitive
- Temperature stable LTCC technology
- Wrap around terminations for excellent solderability
- Low cost



Generic photo used for illustration purposes only  
CASE STYLE: GE0805C-1

**+RoHS Compliant**  
The +Suffix identifies RoHS Compliance.  
See our website for methodologies and qualifications

### APPLICATIONS

- ISM
- WLAN

### ELECTRICAL SPECIFICATIONS AT 25°C

Parameter	Frequency (MHz)	Min.	Typ.	Max.	Unit
Frequency Range		3800		5900	MHz
Insertion Loss, above 3.0 dB	3800 - 5900	—	0.8	1.4	dB
Isolation	3800 - 5900	11	15	—	dB
Phase Unbalance	3800 - 5900	—	1.5	7.0	Degree
Amplitude Unbalance	3800 - 5900	—	0.1	0.5	dB
Return Loss (Input)	3800 - 5900	—	16	—	dB
Return Loss (Output)	3800 - 5900	—	20	—	dB

### MAXIMUM RATINGS

Parameter	Ratings
Operating Temperature	-55°C to 100°C
Storage Temperature	-55°C to 100°C
Power Input (as a splitter)	2W* max.

\* Derate linearly to 0.7W at 100°C ambient, power input as combiner is limited by rating of external resistor 100Ω resistor. Permanent damage may occur if any of these limits are exceeded.

### ELECTRICAL SCHEMATIC

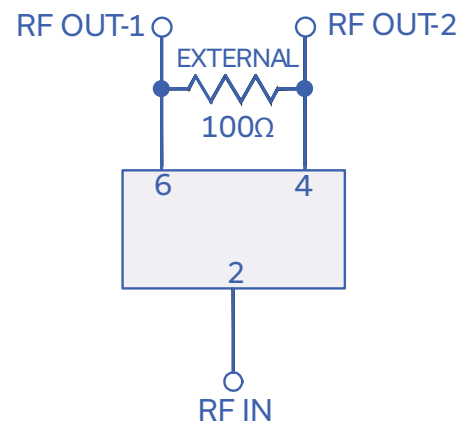

REV. A  
ECO-009562  
SCG-2-592+  
SL/CP/AM  
220928





CERAMIC

# Power Splitter/Combiner

# SCG-2-592+

Mini-Circuits

2 Way-0° 50Ω 3800 to 5900 MHz

### PAD CONNECTIONS

SUM PORT	2
PORT 1	6
PORT 2	4
GROUND	1,3,5
PORT 1-2	resistor external 100 ohms

PRODUCT MARKING: SL

DEMO BOARD MCL P/N: TB-1043+  
SUGGESTED PCB LAYOUT (PL-560)

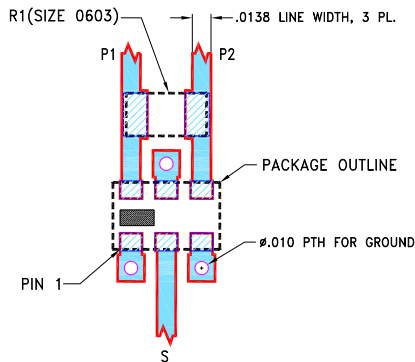

#### NOTES:

1. LINE WIDTH IS SHOWN FOR ROGERS RO4350B WITH DIELECTRIC THICKNESS .0066±.0007. COPPER: 1/2 OZ. EACH SIDE. FOR OTHER MATERIALS LINE WIDTH MAY NEED TO BE MODIFIED.
  2. UNIT FOOT PRINT IS OPTIMIZED FOR PERFORMANCE AND IS DIFFERENT FROM CASE STYLE GE0805C-1 RECOMMENDATIONS.
  3. CHIP COMPONENT FOOT PRINT IS SHOWN FOR REFERENCE. FOR COMPONENT VALUE REFER TO TB-1043+.
  4. BOTTOM SIDE OF THE PCB IS CONTINUOUS GROUND PLANE.
- DENOTES PCB COPPER LAYOUT WITH SMOBC (SOLDER MASK OVER BARE COPPER).  
 DENOTES COPPER LAND PATTERN FREE OF SOLDER MASK.

### OUTLINE DRAWING

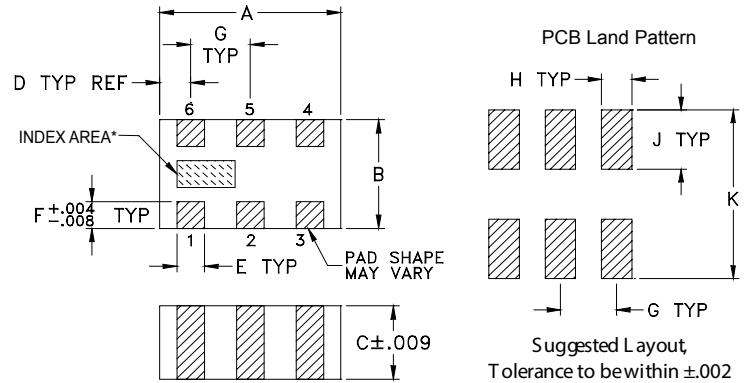

\*Shape of index marking may vary

### OUTLINE DIMENSIONS (Inches/mm)

A	B	C	D	E	F
.079	.049	.033	.014	.012	.012
2.01	1.24	0.84	0.36	0.30	0.30
G	H	J	K		wt
.026	.014	.039	.110		grams
0.66	0.36	1.00	2.80		.008

### TAPE & REEL INFORMATION: F74



CERAMIC

# Power Splitter/Combiner

# SCG-2-592+

Mini-Circuits

2 Way-0° 50Ω 3800 to 5900 MHz

### TYPICAL PERFORMANCE DATA

Frequency (MHz)	Total Loss <sup>1</sup> (dB)		Amplitude Unbalance (dB)	Isolation (dB)	Phase Unbalance (deg.)	Return Loss (dB)		
	S-1	S-2				S	1	2
3800	3.46	3.49	0.03	16.20	0.90	17.33	30.21	27.18
3900	3.48	3.50	0.02	16.83	0.92	17.64	29.49	28.22
4000	3.49	3.50	0.01	17.50	0.99	18.16	29.07	29.36
4100	3.50	3.51	0.01	18.09	1.12	18.90	27.76	30.96
4200	3.51	3.52	0.01	18.53	1.15	19.60	26.19	32.94
4400	3.51	3.51	0.00	20.02	1.23	21.85	23.13	30.89
4600	3.53	3.51	0.02	21.65	1.32	20.17	21.44	28.65
4800	3.56	3.53	0.03	23.05	1.39	18.00	20.01	26.32
4900	3.56	3.53	0.03	24.00	1.39	17.72	19.74	25.82
5000	3.58	3.55	0.04	24.50	1.40	17.01	19.45	25.24
5100	3.60	3.57	0.03	24.60	1.58	16.16	19.09	24.27
5300	3.66	3.64	0.02	23.35	1.77	15.10	17.73	21.16
5500	3.74	3.72	0.01	22.11	2.01	14.69	16.53	18.75
5700	3.86	3.85	0.01	20.15	1.97	12.84	15.08	16.52
5900	3.98	3.98	0.00	18.90	2.02	11.60	14.21	15.13

1. Total Loss = Insertion Loss + 3dB splitter loss.

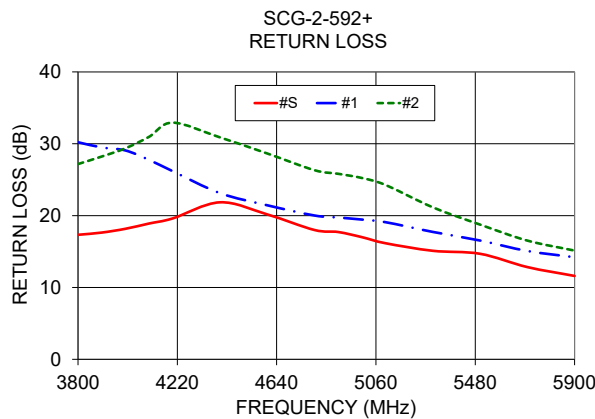
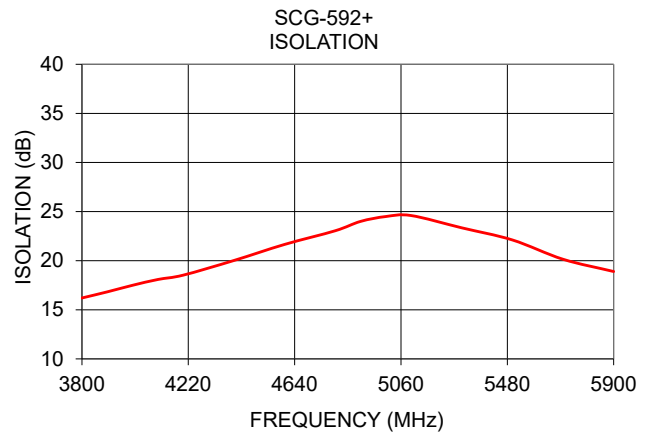
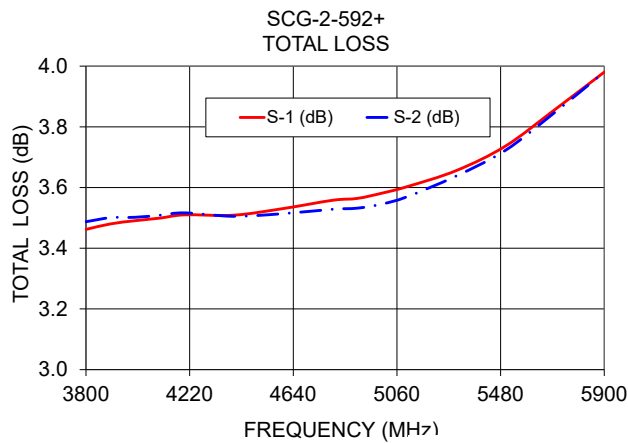

- NOTES**
- A. Performance and quality attributes and conditions not expressly stated in this specification document are intended to be excluded and do not form a part of this specification document.
  - B. Electrical specifications and performance data contained in this specification document are based on Mini-Circuits' applicable established test performance criteria and measurement instructions.
  - C. The parts covered by this specification document are subject to Mini-Circuits standard limited warranty and terms and conditions (collectively, "Standard Terms"); Purchasers of this part are entitled to the rights and benefits contained therein. For a full statement of the standard. Terms and the exclusive rights and remedies thereunder, please visit Mini-Circuits' website at [www.minicircuits.com/terms/viewterm.html](http://www.minicircuits.com/terms/viewterm.html)

