

Memory FRAM

2M (256 K × 8) Bit SPI

MB85RS2MTY

■ DESCRIPTION

MB85RS2MTY is a FRAM (Ferroelectric Random Access Memory) chip in a configuration of 262,144 words × 8 bits, using the ferroelectric process and silicon gate CMOS process technologies for forming the nonvolatile memory cells. This product is targeted for high-temperature environment applications. MB85RS2MTY adopts the Serial Peripheral Interface (SPI).

The MB85RS2MTY is able to retain data without using a back-up battery, as is needed for SRAM.

The memory cells used in the MB85RS2MTY can be used for 10^{13} read/write operations, which is a significant improvement over the number of read and write operations supported by Flash memory and E²PROM.

As MB85RS2MTY does not need any waiting time in writing process, the write cycle time of MB85RS2MTY is much shorter than that of Flash memories or E²PROM.

■ FEATURES

- Bit configuration : 262,144 words × 8 bits
- Serial Sector Region : 256 words × 8 bits
In this region, data storage after (by) three times reflow based on JEDEC MSL-3 standard condition is guaranteed.
- Unique ID
- Serial Number
- Serial Peripheral Interface : SPI (Serial Peripheral Interfaces)
Correspondent to SPI mode 0 (0, 0) and mode 3 (1, 1)
- Operating frequency : 50 MHz (Max)
- High endurance : 10^{13} times / byte
- Data retention : 10 years (+85 °C)
2.75years (+105 °C)
0.85 years (+125 °C) or more
Under evaluation for more than 2.5years(+125 °C)
- Operating power supply voltage : 1.8 V to 3.6 V
- Low power consumption : Operating power supply current 4 mA (Max@50 MHz)
Standby current 220 μA (Max)
Deep Power Down current 30 μA (Max)
- Operation ambient temperature range : - 40 °C to +125 °C
- Package : 8-pin plastic SOP 150mil
8-pin plastic DFN 5mm × 6mm
RoHS compliant

MB85RS2MTY

■ PIN ASSIGNMENT

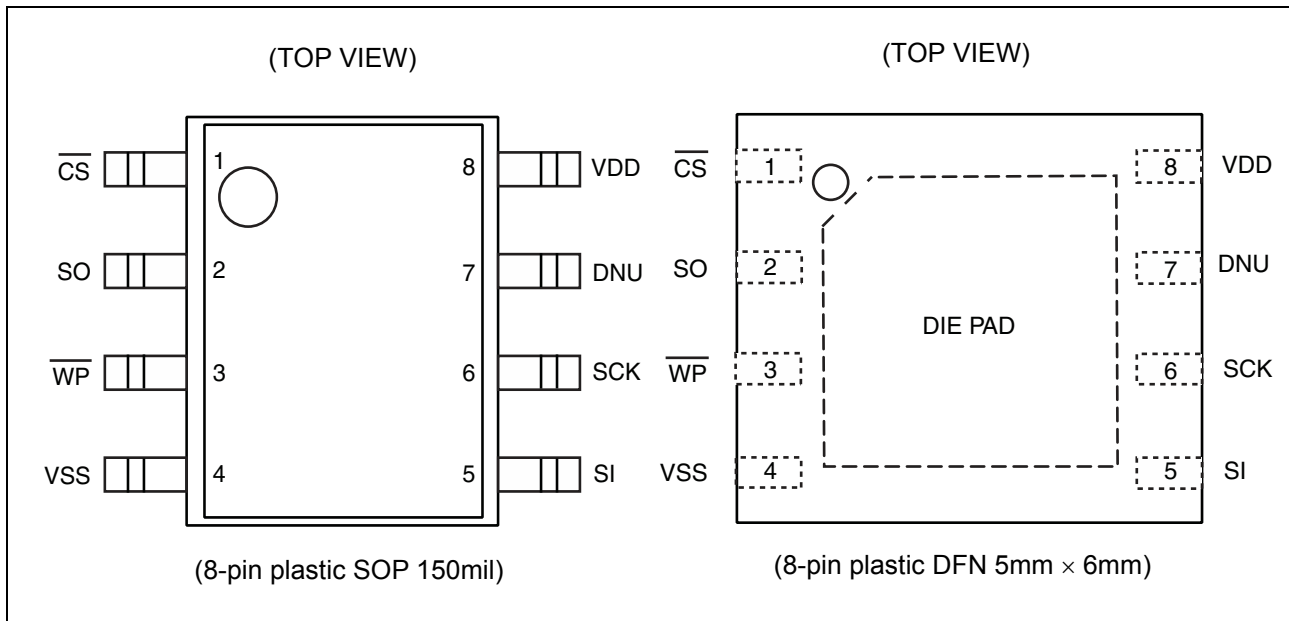

■ PIN FUNCTIONAL DESCRIPTIONS

Pin No.	Pin Name	Functional description
1	\overline{CS}	Chip Select pin This is an input pin to make chips select. When \overline{CS} is "H" level, device is in deselect (standby) status and SO becomes High-Z. Inputs from other pins are ignored for this time. When \overline{CS} is "L" level, device is in select (active) status. \overline{CS} has to be "L" level before inputting op-code.
3	\overline{WP}	Write Protect pin This is a pin to control writing to a status register. The writing of status register (see "■ STATUS REGISTER") is protected in related with \overline{WP} and WPEN. See "■ WRITING PROTECT" for detail.
7	DNU	DNU pin This pin is not used. It is allowed to be floating (no connection) or to be connected to VDD or VSS.
6	SCK	Serial Clock pin This is a clock input pin to input/output serial data. SI is loaded synchronously to a rising edge, SO is output synchronously to a falling edge.
5	SI	Serial Data Input pin This is an input pin of serial data. This inputs op-code, address, and writing data.
2	SO	Serial Data Output pin This is an output pin of serial data. Reading data of FRAM memory cell array and status register data are output. This is High-Z during standby.
8	VDD	Supply Voltage pin
4	VSS	Ground pin
DIE PAD	—	It is allowed for the DIE PAD on the bottom of the DFN8 package to be floating (no connection to anything) or to be connected to VSS.

■ BLOCK DIAGRAM

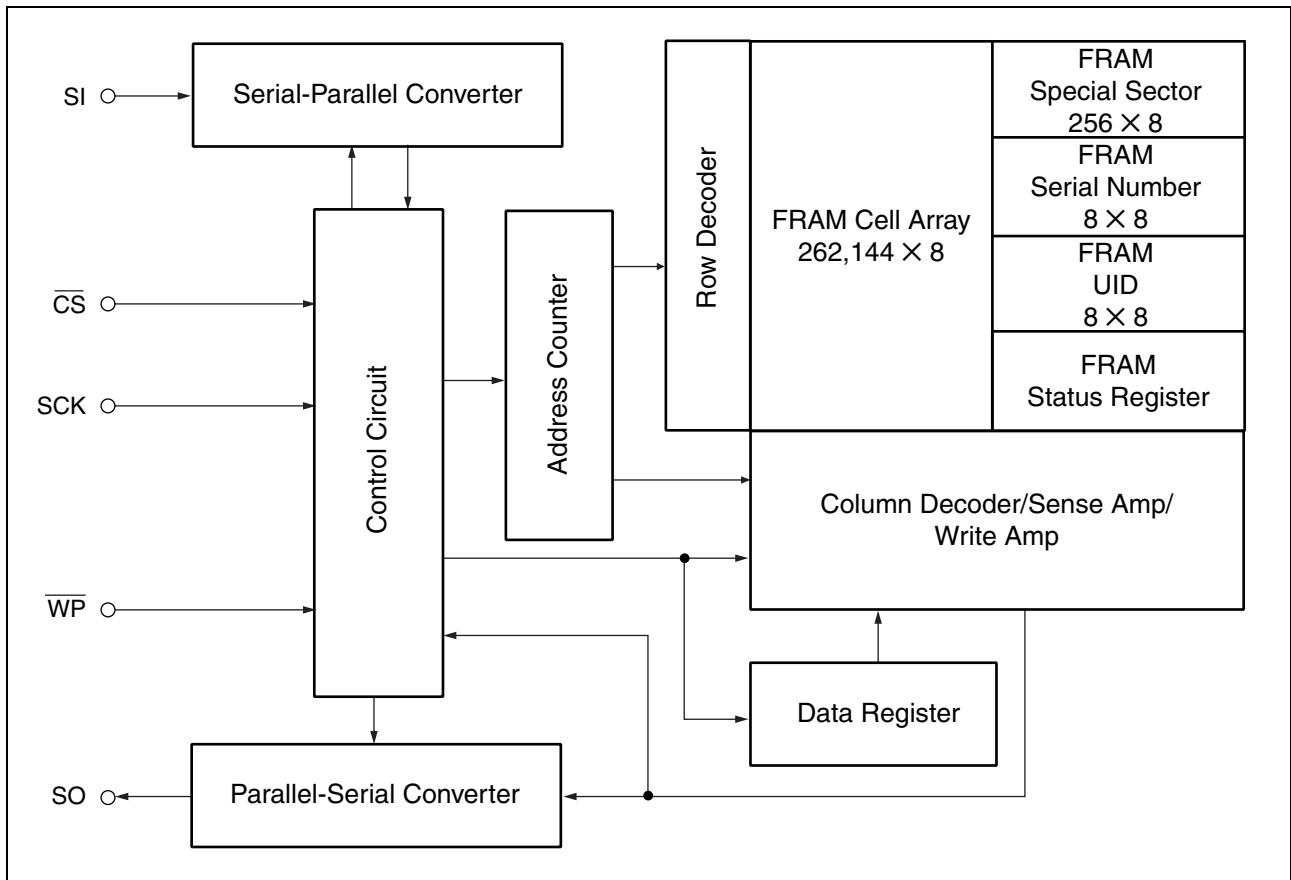

MB85RS2MTY

■ SPI MODE

MB85RS2MTY corresponds to the SPI mode 0 (CPOL = 0, CPHA = 0), and SPI mode 3 (CPOL = 1, CPHA = 1).

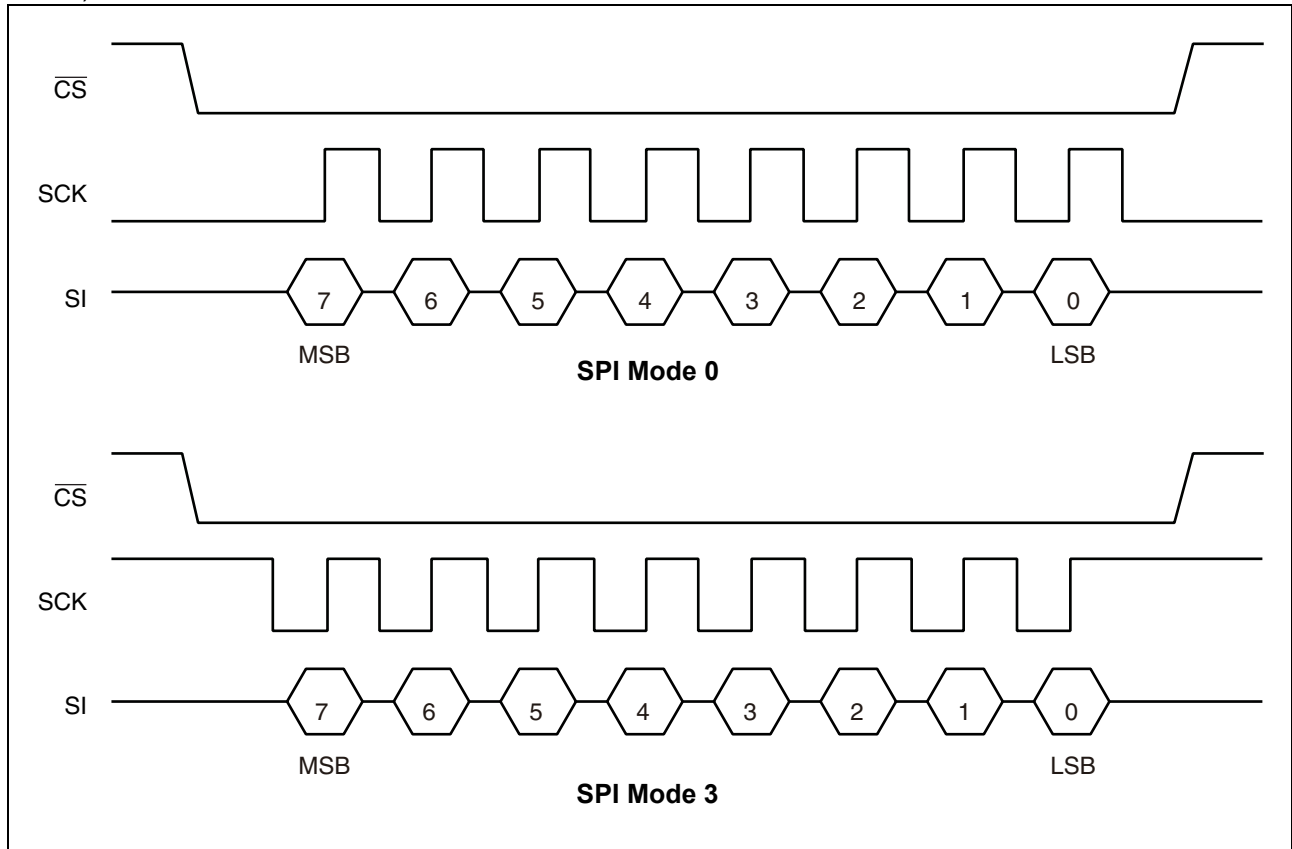

■ SERIAL PERIPHERAL INTERFACE (SPI)

MB85RS2MTY works as a slave of SPI. More than 2 devices can be connected by using microcontroller equipped with SPI port. By using a microcontroller not equipped with SPI port, SI and SO can be bus connected to use.

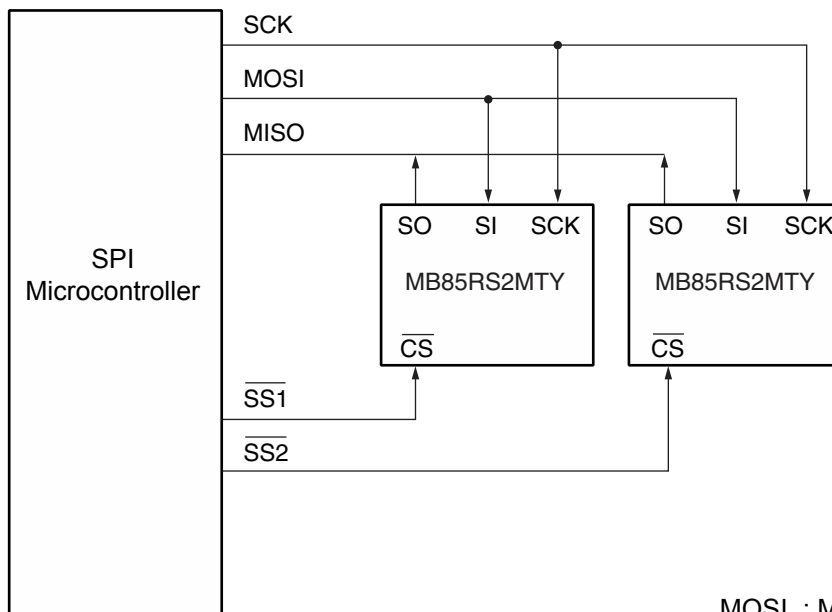

MOSI : Master Out Slave In
MISO : Master In Slave Out
SS : Slave Select

System Configuration with SPI Port

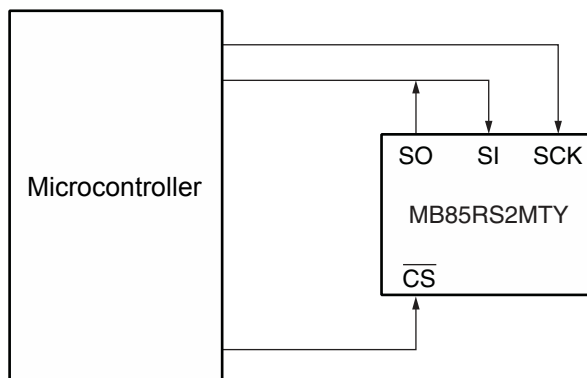

System Configuration without SPI Port

■ STATUS REGISTER

Bit No.	Bit Name	Function
7	WPEN	<p>Status Register Write Protect</p> <p>This is a bit composed of nonvolatile memories (FRAM). WPEN protects writing to a status register (refer to “■ WRITING PROTECT”) relating with \overline{WP} input. Writing with the WRSR command and reading with the RDSR command are possible.</p>
6 to 4	—	<p>Not Used Bits</p> <p>These are bits composed of nonvolatile memories, writing with the WRSR command is possible. These bits are not used but they are read with the RDSR command.</p>
3	BP1	<p>Block Protect</p> <p>This is a bit composed of nonvolatile memory. This defines size of write protect block for the WRITE command (refer to “■ BLOCK PROTECT”). Writing with the WRSR command and reading with the RDSR command are possible.</p>
2	BP0	
1	WEL	<p>Write Enable Latch</p> <p>This indicates FRAM Array and status register are writable. The WREN command is for setting, and the WRDI command is for resetting. With the RDSR command, reading is possible but writing is not possible with the WRSR command. WEL is reset after the following operations.</p> <ul style="list-style-type: none"> After power ON. After WRDI command recognition. After return from DPD mode. <p>Achieving continuous writing mode, WEL is not reset after following operations making it possible to execute writing commands continuously.</p> <ul style="list-style-type: none"> After WRSR command recognition. After WRITE command recognition. After WRSN command recognition. After SSWR command recognition.
0	0	This is a bit fixed to “0”.

■ OP-CODE

MB85RS2MTY accepts 15 kinds of command specified in op-code. Op-code is a code composed of 8 bits shown in the table below. Do not input invalid codes other than those codes. If \overline{CS} is risen while inputting op-code, the command are not performed.

Name	Description	Op-code
WREN	Set Write Enable Latch	0000 0110 _B
WRDI	Reset Write Enable Latch	0000 0100 _B
RDSR	Read Status Register	0000 0101 _B
WRSR	Write Status Register	0000 0001 _B
READ	Read Memory Code	0000 0011 _B
WRITE	Write Memory Code	0000 0010 _B
FSTRD	Fast Read Memory Code	0000 1011 _B
DPD	Deep Power Down Mode	1011 1010 _B
RDID	Read Device ID	1001 1111 _B
RUID	Read Unique ID	0100 1100 _B
WRSN	Write Serial Number	1100 0010 _B
RDSN	Read Serial Number	1100 0011 _B
SSWR	Write Special Sector	0100 0010 _B
SSRD	Read Special Sector	0100 1011 _B
FSSRD	Fast Read Special Sector	0100 1001 _B
RFU	Reserved	1011 1001 _B
		1100 0001 _B
		1100 0110 _B
		1100 1110 _B
		1100 1111 _B

■ COMMAND

• WREN

The WREN command sets WEL (Write Enable Latch) bit to 1. WEL has to be set with the WREN command before writing operation (WRSR command, WRITE command, WRSN command and SSWR command) .

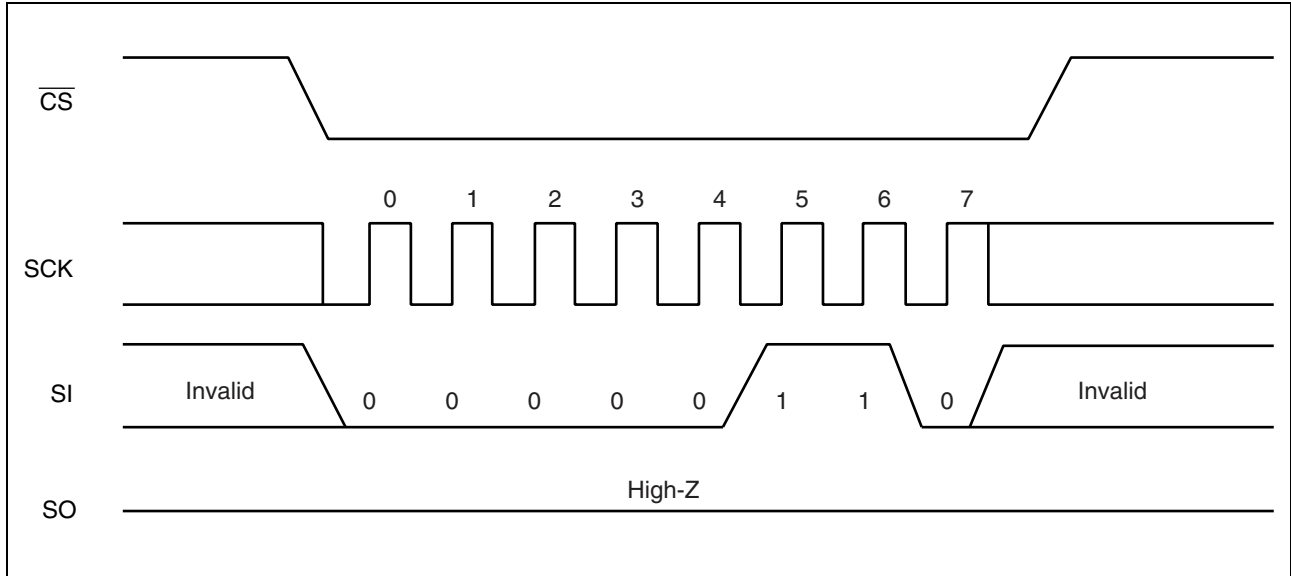

• WRDI

The WRDI command resets WEL (Write Enable Latch) bit to 0. Writing operation (WRSR command, WRITE command, WRSN command and SSWR command) are not performed when WEL is reset.

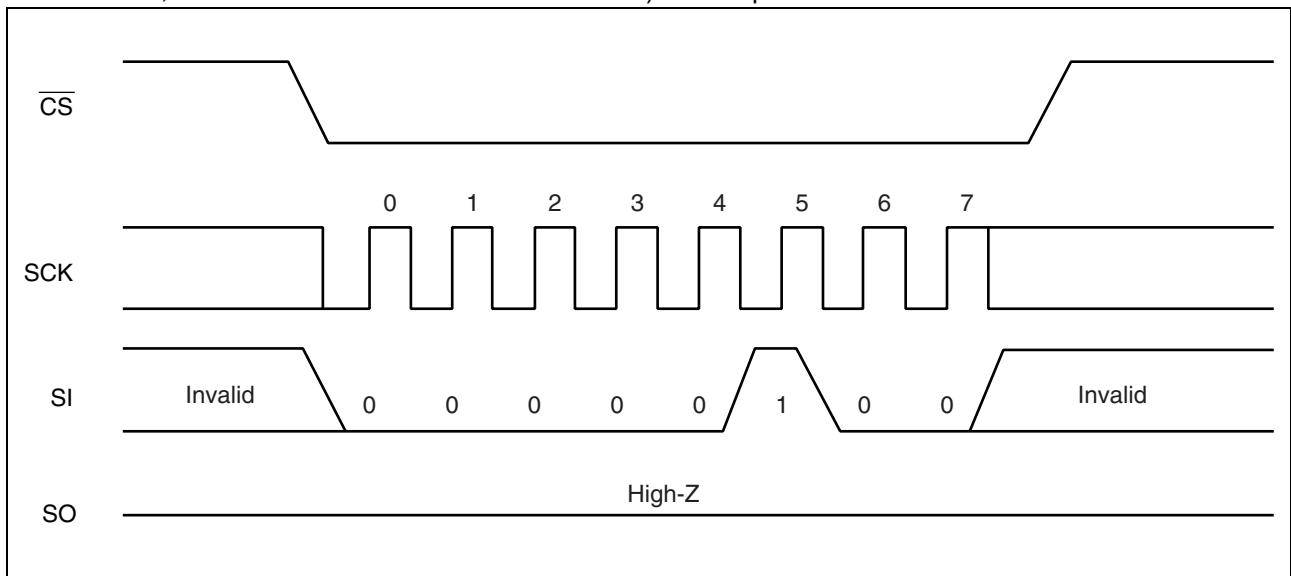

• RDSR

The RDSR command reads status register data. After op-code of RDSR is input to SI, 8-cycle clock is input to SCK. The SI value is invalid for this time. SO is output synchronously to a falling edge of SCK. In the RDSR command, repeated reading of status register is enabled by sending SCK continuously before rising of \overline{CS} .

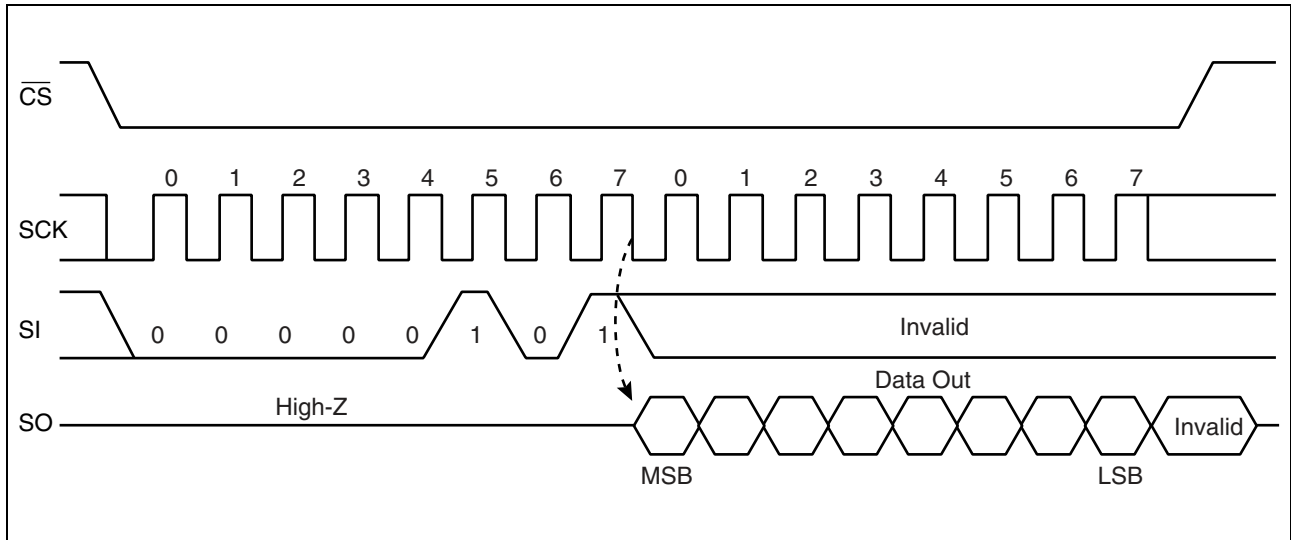

• WRSR

The WRSR command writes data to the nonvolatile memory bit of status register. After performing WRSR op-code to a SI pin, 8 bits writing data is input. WEL (Write Enable Latch) is not able to be written with WRSR command. A SI value correspondent to bit 1 is ignored. Bit 0 of the status register is fixed to "0" and cannot be written. The SI value corresponding to bit 0 is ignored. \overline{WP} signal level shall be fixed before performing WRSR command, and do not change the \overline{WP} signal level until the end of command sequence.

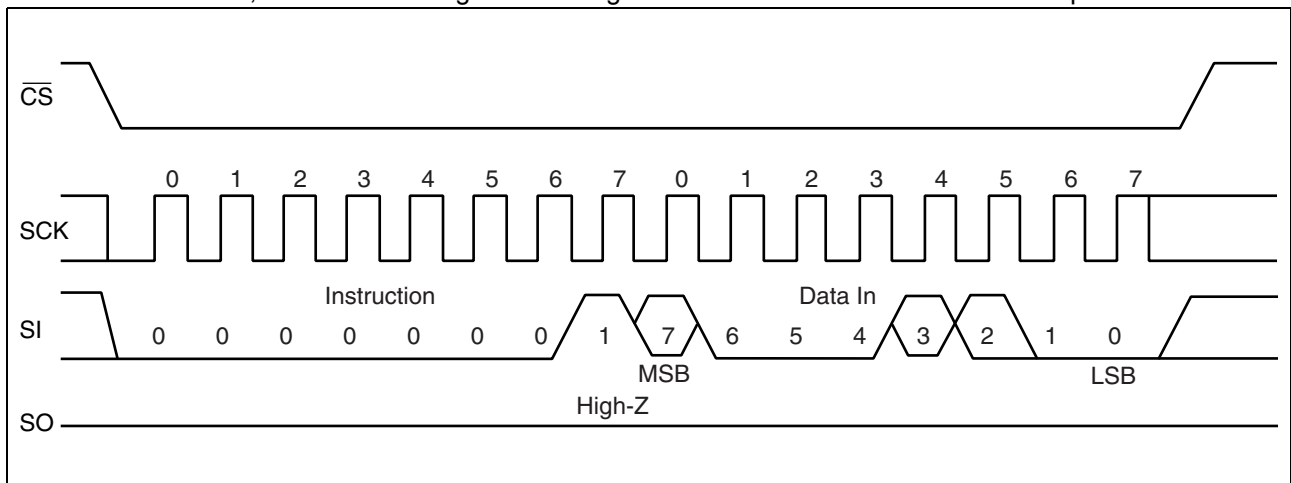

MB85RS2MTY

• READ

The READ command reads FRAM memory cell array data. Arbitrary 16 bits address and op-code of READ are input to SI. The most significant address bit is invalid. Then, 8-cycle clock is input to SCK. SO is output synchronously to the falling edge of SCK. While reading, the SI value is invalid. When \overline{CS} is risen, the READ command is completed, but keeps on reading with automatic address increment which is enabled by continuously sending clocks to SCK in unit of 8 cycles before \overline{CS} rising. When it reaches the most significant address, it rolls over to the starting address, and reading cycle keeps on infinitely.

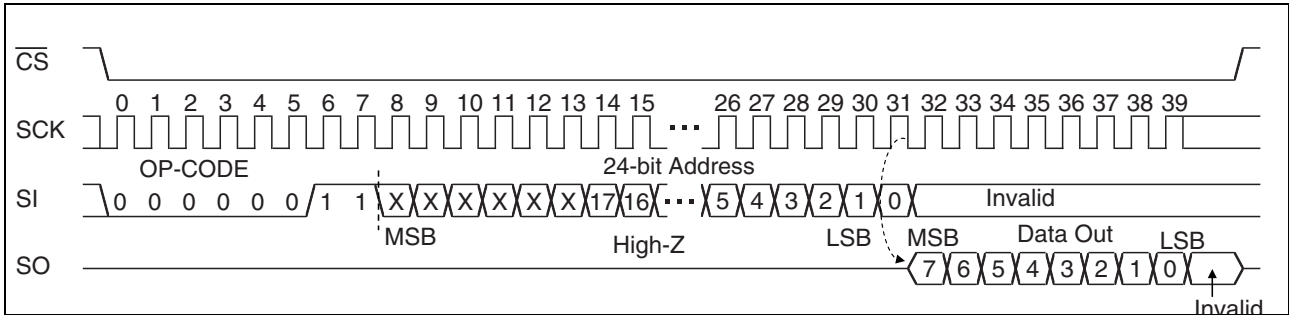

• WRITE

The WRITE command writes data to FRAM memory cell array. WRITE op-code, arbitrary 16 bits of address and 8 bits of writing data are input to SI. The most significant address bit is invalid. When 8 bits of writing data is input, data is written to FRAM memory cell array. Risen \overline{CS} will terminate the WRITE command, but if you continue sending the writing data for 8 bits each before \overline{CS} rising, it is possible to continue writing with automatic address increment. When it reaches the most significant address, it rolls over to the starting address, and writing cycle can be continued infinitely.

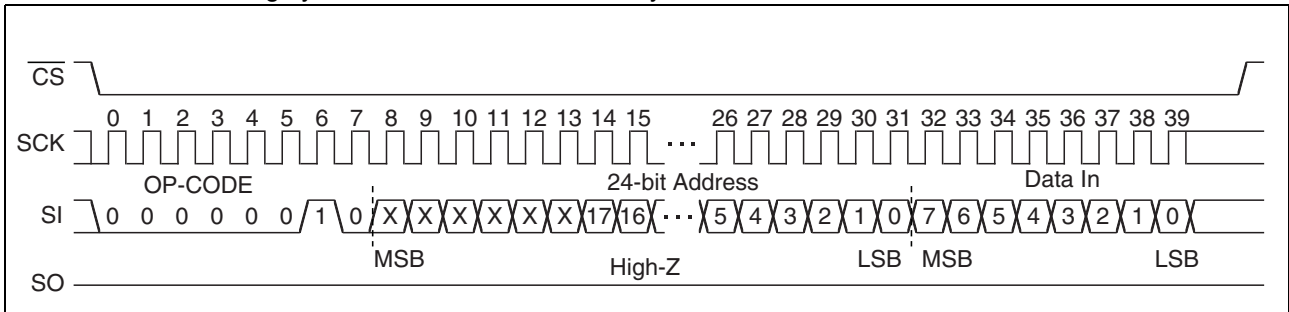

• FSTRD

The FSTRD command reads FRAM memory cell array data. Arbitrary 24 bits address and op-code of FSTRD are input to SI followed by 8 bits dummy. The 6-bit upper address bit is invalid. Then, 8-cycle clock is input to SCK. SO is output synchronously to the falling edge of SCK. While reading, the SI value is invalid. When \overline{CS} is risen, the FSTRD command is completed, but keeps on reading with automatic address increment which is enabled by continuously sending clocks to SCK in unit of 8 cycles before \overline{CS} rising. When it reaches the most significant address, it rolls over to the starting address, and reading cycle keeps on infinitely.

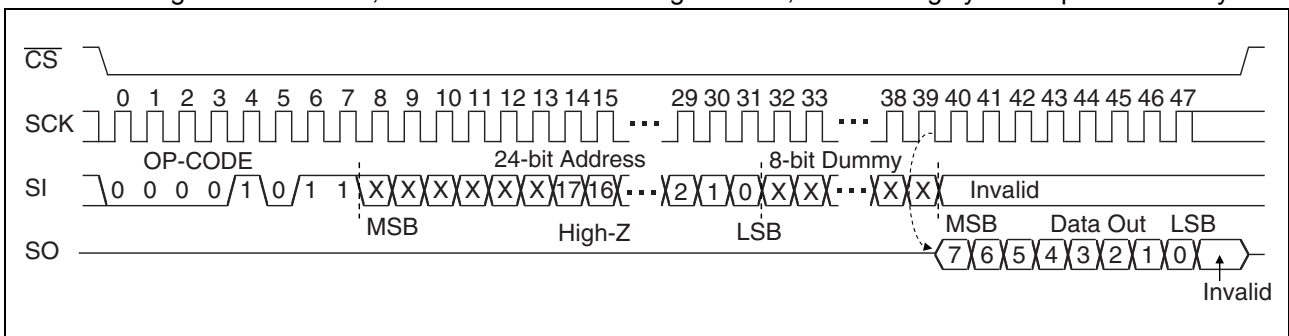

• RDID

The RDID command reads fixed Device ID. After performing RDID op-code to SI, 32-cycle clock is input to SCK. The SI value is invalid for this time. SO is output synchronously to a falling edge of SCK. The output is in order of Manufacturer ID (8bit)/Continuation code (8bit)/Product ID (1st Byte)/Product ID (2nd Byte). In the RDID command, 32-bit Device ID is output by continuously sending SCK clock, and SO holds the output state of the last bit until \overline{CS} is risen.

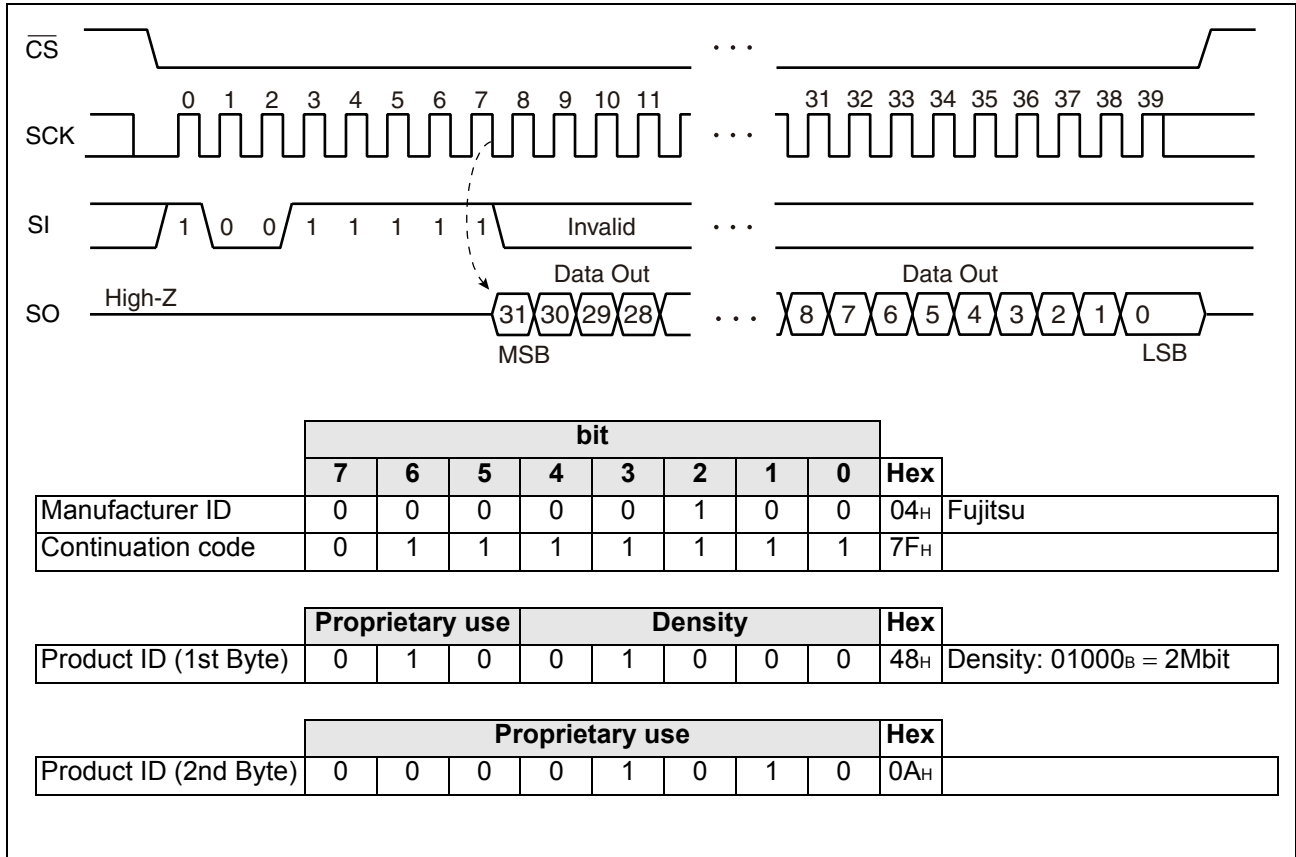

• RUID

The RUID command reads an unique ID which is defined in 64bits for each device. After performing RUID op-code to SI, 64-cycle clock is input to SCK. The SI value is invalid for this time. SO is output synchronously to a falling edge of SCK.

The unique ID is stable between before and after reflow. Refer “■ REFLOW CONDITIONS AND FLOOR LIFE” for the reflow condition.

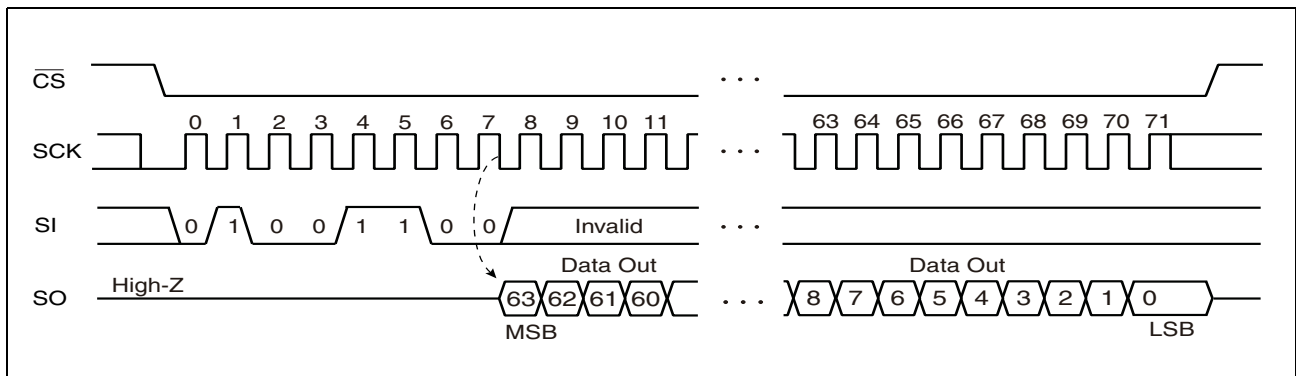

MB85RS2MTY

•WRSN

The WRSN command writes data to serial number region which is allowed to write only one time. After performing WRSN op-code to SI, 64bits of writing data is input. Once wrote, the serial number region is protected, disabling to overwrite even when issuing WRSN command.

\overline{WP} signal level shall be fixed before performing WRSN command, and do not change the \overline{WP} signal level until the end of command sequence.

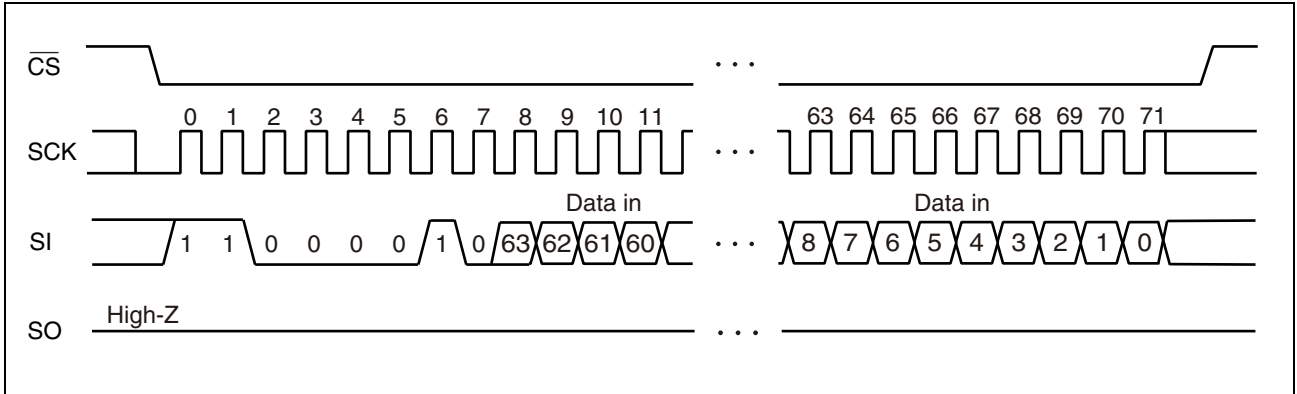

•RDSN

The RDSN command reads 64 bits of serial number which is written using WRSN command. After performing RDSN op-code to SI, 64-cycle clock to SCK. The SI value is invalid for this time. SO is output synchronously to a falling edge of SCK. When reading serial number from devices which no WRSN command is executed, "0" for all bits are output.

The serial number is stable between before and after reflow. Refer "■ REFLOW CONDITIONS AND FLOOR LIFE" for the reflow condition.

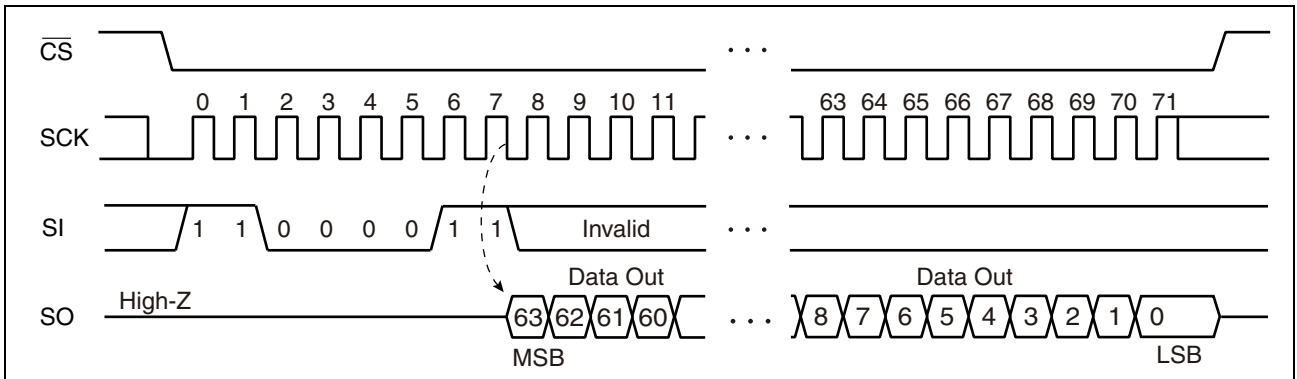

- SSWR

The SSWR command writes data to special sector (a special region of 256 Byte in FRAM). SSWR op-code, arbitrary 24 bits address and 8-bit writing data are input to SI. The 16-bit upper address is invalid. When input of 8-bit writing data is completed, it starts writing data to special sector. Risen \overline{CS} will terminate the SSWR command, but if you continue the writing data for each before \overline{CS} rising, it is possible to continue writing with automatic address increment. When it reaches the most significant address, roll over is not happen, the data hereafter is ignored.

The data in special sector is stable between before and after reflow. Refer “■ REFLOW CONDITIONS AND FLOOR LIFE” for the reflow condition.

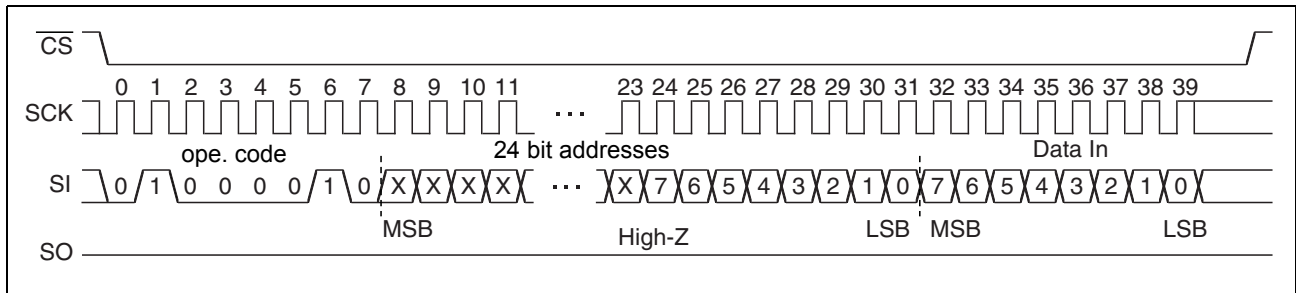

- SSRD

The SSRD command reads data from special sector (a special region of 256 Byte in FRAM). SSWR op-code and arbitrary 24 bits address are input to SI. The 16-bit upper address is invalid. Then, 8-cycle clock is input to SCK. SO is output synchronously to the falling edge of SCK. While reading, the SI value is invalid. When \overline{CS} is risen, the SSRD command is completed, but keeps on reading with automatic address increment which is enabled by continuously sending clocks to SCK in unit of 8 cycles before \overline{CS} rising. When it reaches the most significant address, roll over is not happen.

The data in special sector is stable between before and after reflow. Refer “■ REFLOW CONDITIONS AND FLOOR LIFE” for the reflow condition.

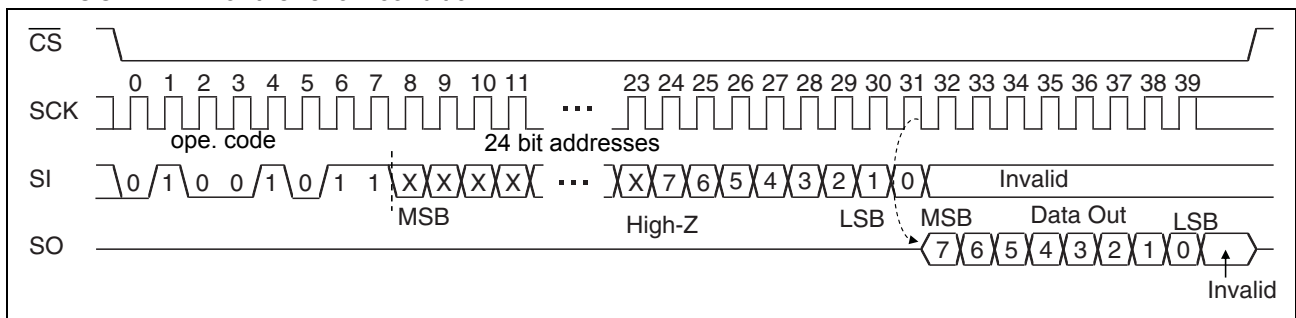

MB85RS2MTY

- FSSRD

The SSRD command reads data from special sector (a special region of 256 Byte in FRAM). SSWR opcode and arbitrary 24 bits address are input to SI followed by 8 bits dummy. The 16-bit upper address is invalid. Then, 8-cycle clock is input to SCK. SO is output synchronously to the falling edge of SCK. While reading, the SI value is invalid. When \overline{CS} is risen, the SSRD command is completed, but keeps on reading with automatic address increment which is enabled by continuously sending clocks to SCK in unit of 8 cycles before \overline{CS} rising. When it reaches the most significant address, roll over is not happen.

The data in special sector is stable between before and after reflow. Refer “■ REFLOW CONDITIONS AND FLOOR LIFE” for the reflow condition.

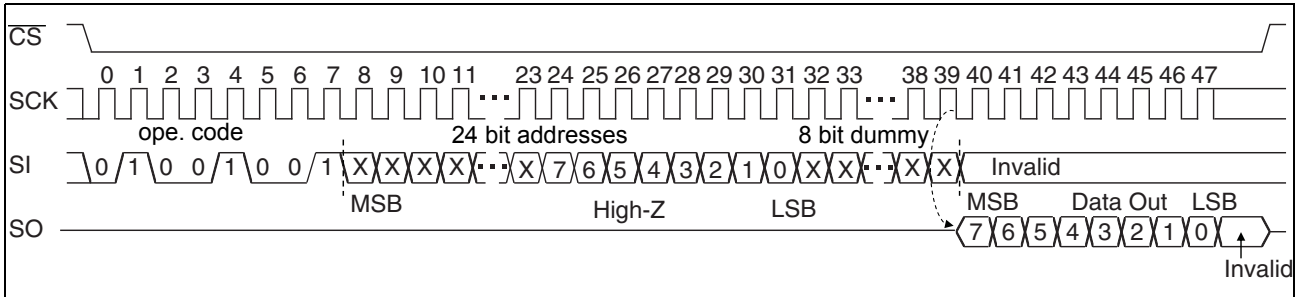

- DPD(Deep Power Down)

The DPD command shifts the LSI to a low power mode called “DPD mode”. The transition to the DPD mode is carried out at the rising edge of \overline{CS} after operation code in the DPD command. However, when at least one SCK clock is inputted before the rising edge of \overline{CS} after operation code in the DPD command, this DPD command is canceled.

After the DPD mode transition, SCK and SI inputs are ignored and SO changes to a High-Z state.

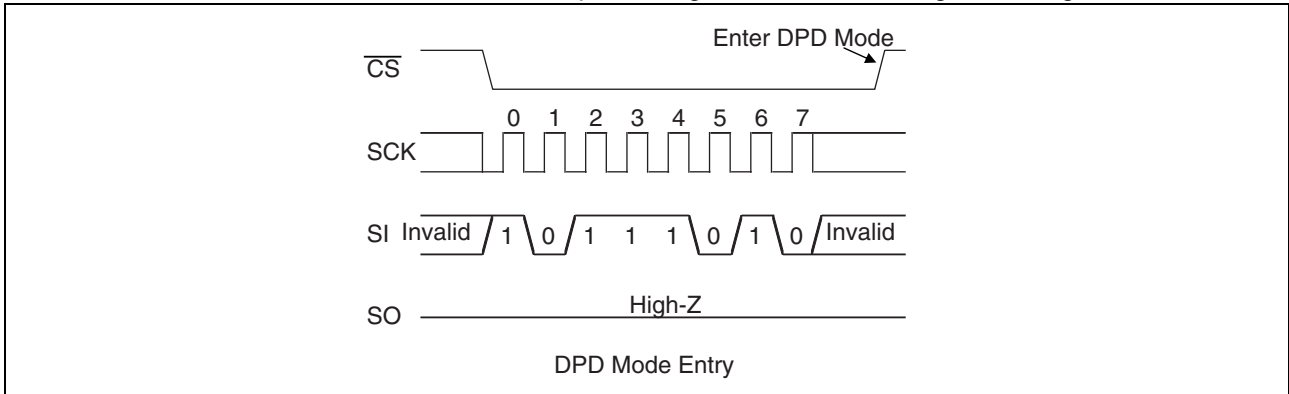

Returning to an normal operation from the DPD mode is carried out after t_{RECDPD} (Max 10 μ s) time from the falling edge of \overline{CS} (see the figure below). It is possible to return \overline{CS} to H level before t_{RECDPD} time. However, it is prohibited to bring down \overline{CS} to L level again during t_{RECDPD} period.

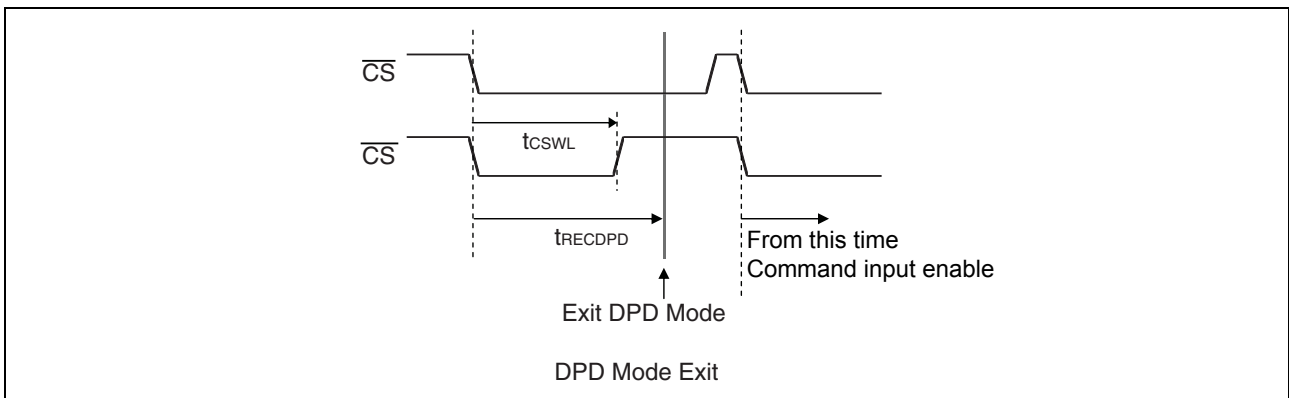

■ BLOCK PROTECT

Writing protect block for WRITE command is configured by the value of BP0 and BP1 in the status register.

BP1	BP0	Protected Block
0	0	None
0	1	30000 _H to 3FFFF _H (upper 1/4)
1	0	20000 _H to 3FFFF _H (upper 1/2)
1	1	00000 _H to 3FFFF _H (all)

■ WRITING PROTECT

Writing operation of the WRITE command and the WRSR command are protected with the value of WEL, WPEN, WP as shown in the table.

WEL	WPEN	WP	Protected Blocks	Unprotected Blocks	Status Register
0	X	X	Protected	Protected	Protected
1	0	X	Protected	Unprotected	Unprotected
1	1	0	Protected	Unprotected	Protected
1	1	1	Protected	Unprotected	Unprotected

MB85RS2MTY

■ ABSOLUTE MAXIMUM RATINGS

Parameter	Symbol	Rating		Unit
		Min	Max	
Power supply voltage*	V_{DD}	- 0.5	+ 4.0	V
Input voltage*	V_{IN}	- 0.5	$V_{DD} + 0.5 (\leq 4.0)$	V
Output voltage*	V_{OUT}	- 0.5	$V_{DD} + 0.5 (\leq 4.0)$	V
Operation ambient temperature	T_A	- 40	+ 125	°C
Storage temperature	T_{stg}	- 55	+ 150	°C

*: These parameters are based on the condition that V_{SS} is 0 V.

WARNING: Semiconductor devices may be permanently damaged by application of stress (including, without limitation, voltage, current or temperature) in excess of absolute maximum ratings.
Do not exceed any of these ratings.

■ RECOMMENDED OPERATING CONDITIONS

Parameter	Symbol	Value			Unit
		Min	Typ	Max	
Power supply voltage*1	V_{DD}	1.8	3.3	3.6	V
Operation ambient temperature*2	T_A	- 40	—	+ 125	°C

*1: These parameters are based on the condition that V_{SS} is 0 V.

*2: Ambient temperature when only this device is working. Please consider it to be the almost same as the package surface temperature.

WARNING: The recommended operating conditions are required in order to ensure the normal operation of the semiconductor device. All of the device's electrical characteristics are warranted when the device is operated under these conditions.

Any use of semiconductor devices will be under their recommended operating condition. Operation under any conditions other than these conditions may adversely affect reliability of device and could result in device failure.

No warranty is made with respect to any use, operating conditions or combinations not represented on this data sheet. If you are considering application under any conditions other than listed herein, please contact sales representatives beforehand.

■ ELECTRICAL CHARACTERISTICS

1. DC Characteristics

(within recommended operating conditions)

Parameter	Symbol	Condition	Value			Unit	
			Min	Typ	Max		
Input leakage current*1	I _{Li}	$\overline{CS} = V_{DD}$	25 °C	—	—	1	μA
			125 °C	—	—	2	
		$\overline{WP}, \overline{SCK}, \overline{CS}$ SI = 0 V to V _{DD}	25 °C	—	—	1	
			125 °C	—	—	2	
Output leakage current*2	I _{Lo}	SO = 0 V to V _{DD}	25 °C	—	—	1	μA
			125 °C	—	—	2	
Operating power supply current*3	I _{DD}	SCK = 50MHz	—	3.2	4	mA	
Standby current	I _{SB}	SCK = SI = \overline{CS} = $\overline{WP} = V_{DD}$	—	11	220	μA	
Sleep current	I _{ZZ}	$\overline{CS} = V_{DD}$ All inputs V _{SS} or V _{DD}	—	6	30	μA	
Input high voltage	V _{IH}	V _{DD} = 1.8 V to 3.6 V	V _{DD} × 0.7	—	V _{DD} + 0.3	V	
Input low voltage	V _{IL}	V _{DD} = 1.8 V to 3.6 V	- 0.3	—	V _{DD} × 0.3	V	
Output high voltage	V _{OH}	I _{OH} = - 2 mA	V _{DD} - 0.5	—	—	V	
Output low voltage	V _{OL}	I _{OL} = 2 mA	—	—	0.4	V	

*1 : Applicable pin : \overline{CS} , \overline{WP} , SCK, SI

*2 : Applicable pin : SO

*3 : Input voltage magnitude : V_{DD} - 0.2 V or V_{SS}

2. AC Characteristics

Parameter	Symbol	Value		Unit	Condition V _{DD}
		Min	Max		
SCK clock frequency	f _{CK}	—	50	MHz	all commands except for READ/SSRD
		—	40		READ command
		—	10		SSRD command
Clock high time	t _{CH}	9	—	ns	
Clock low time	t _{CL}	9	—	ns	
Chip select set up time	t _{CSU}	11	—	ns	
Chip select hold time	t _{CSH}	5	—	ns	
Output disable time	t _{OD}	—	10	ns	
Output data valid time	t _{ODV}	—	9	ns	*1
Output hold time	t _{OH}	0	—	ns	
Deselect time	t _D	40	—	ns	
Data in rising time	t _R	—	50	ns	
Data falling time	t _F	—	50	ns	
Data set up time	t _{SU}	5	—	ns	
Data hold time	t _H	5	—	ns	
DPD recovery pulse width	t _{CSWL}	100	—	ns	
DPD recovery time	t _{RECDPD}	—	10	μs	

*1: In SSRD command, 60ns(max.)

AC Test Condition

Power supply voltage	: 1.8 V to 3.6 V Operation
Operation ambient temperature	: - 40 °C to + 125 °C
Input voltage magnitude	: $V_{DD} \times 0.8 \leq V_{IH} \leq V_{DD}$ $0 \leq V_{IL} \leq V_{DD} \times 0.2$
Input rising time	: 5 ns
Input falling time	: 5 ns
Input judge level	: V _{DD} /2
Output judge level	: V _{DD} /2

AC Load Equivalent Circuit

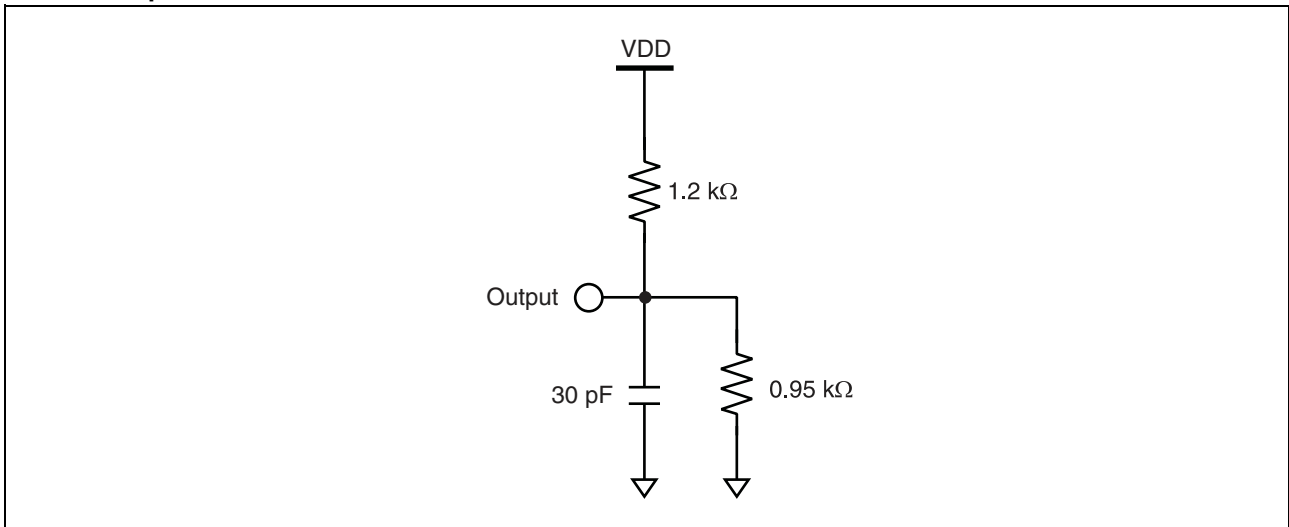

3. Pin Capacitance

Parameter	Symbol	Condition	Value		Unit
			Min	Max	
Output capacitance	C_O	$V_{DD} = 3.3 \text{ V}$, $V_{IN} = V_{OUT} = 0 \text{ V to } V_{DD}$, $f = 1 \text{ MHz}$, $T_A = +25 \text{ }^\circ\text{C}$	—	8	pF
Input capacitance	C_I		—	6	pF

■ TIMING DIAGRAM

• Serial Data Timing

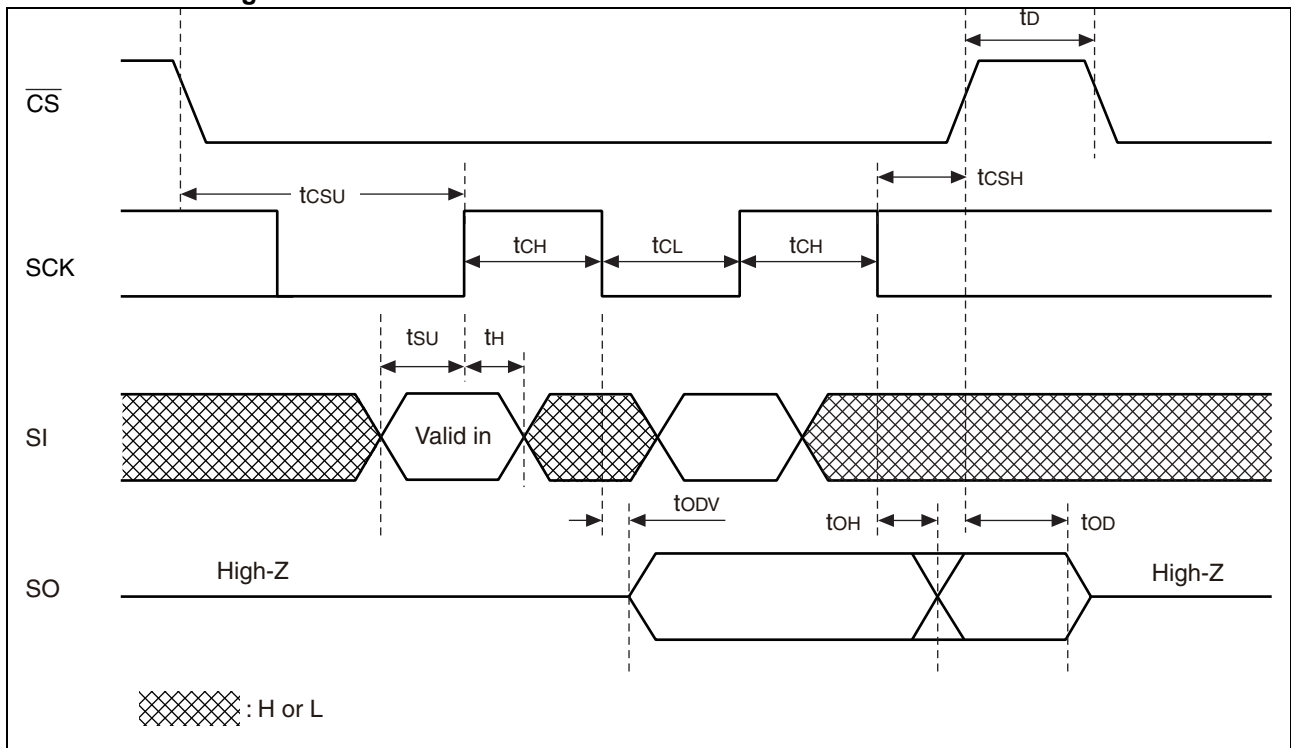

■ POWER ON/OFF SEQUENCE

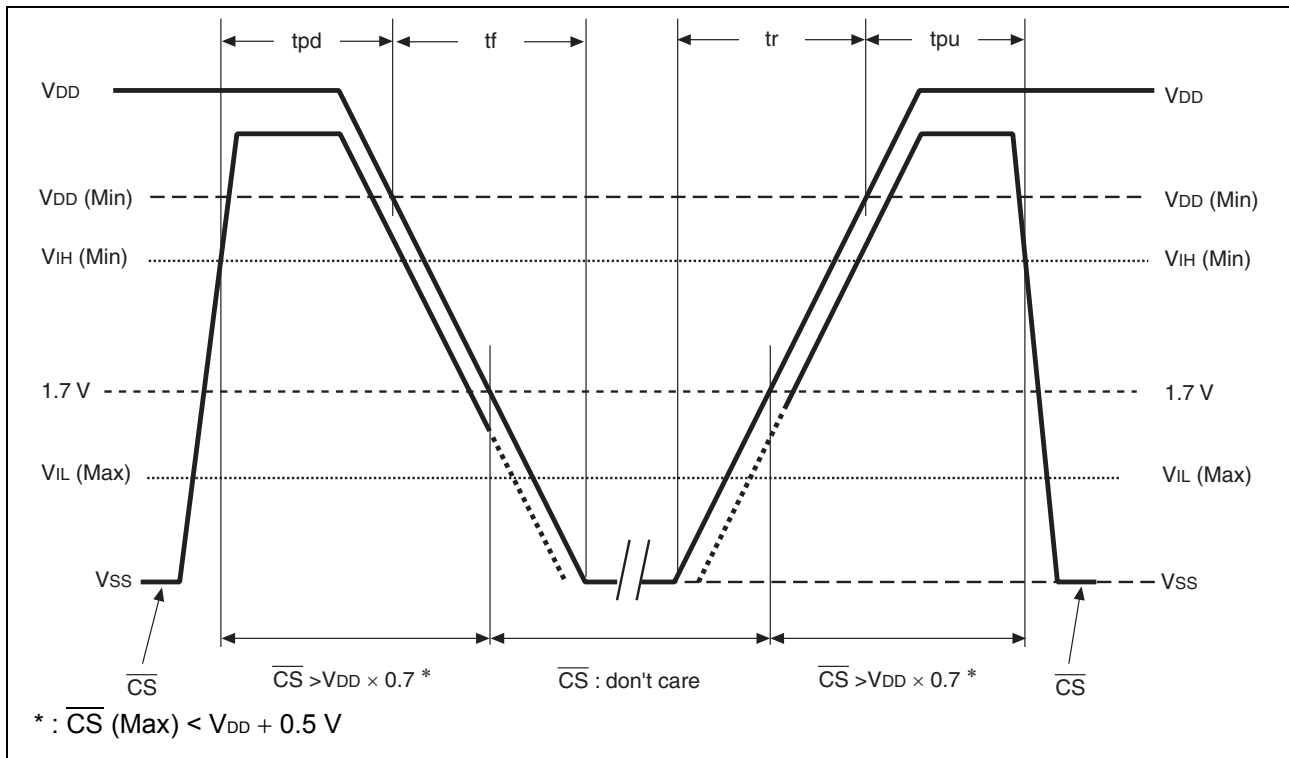

In case relative short V_{DD} pulse whose peak level is beyond 1.7 is applied, please set V_{DD} falling time, t_f , longer than 0.4ms/V. (When V_{DD} rises beyond 1.7V, and falls just after, if this term is very short the device may loose its function.)

Parameter	Symbol	Value		Unit	Condition V_{DD}
		Min	Max		
\overline{CS} level hold time at power OFF	tpd	400	—	ns	1.8V to 2.7V
		0	—		2.7V to 3.6V
\overline{CS} level hold time at power ON	tpu	450	—	μs	—
Power supply rising time	tr	0.05	—	ms/V	—
Power supply falling time	tf	0.1	—	ms/V	—

If the device does not operate within the specified conditions of read cycle, write cycle or power on/off sequence, memory data can not be guaranteed.

MB85RS2MTY

■ FRAM CHARACTERISTICS

Parameter	Value		Unit	Remarks
	Min	Max		
Read/Write Endurance*1	10 ¹³	—	Times/byte	Operation Ambient Temperature T _A = + 125 °C
Data Retention*2	0.85 or more*3	—	Years	Operation Ambient Temperature T _A = + 125 °C
	2.75	—		Operation Ambient Temperature T _A = + 105 °C
	10	—		Operation Ambient Temperature T _A = + 85 °C

*1 : Total number of reading and writing defines the minimum value of endurance, as an FRAM memory operates with destructive readout mechanism.

*2: Minimum values define retention time of the first reading/writing data right after shipment, and these values are calculated by qualification results.

*3: Under evaluation for more than 0.85years(+125 °C).

■ NOTE ON USE

We recommend programming of the device after reflow except for special sector region and serial number region. Data written before reflow cannot be guaranteed.

■ ESD AND LATCH-UP

(8-pin plastic SOP 150mi)

Test	DUT	Value
ESD HBM (Human Body Model) JESD22-A114 compliant	MB85RS2MTYPNF-G-AWE2 MB85RS2MTYPNF-G-AWERE2	≥ 2000 V
ESD CDM (Charged Device Model) JESD22-C101		≥ 1500 V
Latch-Up (I-test) JESD78 compliant		≥ 125mA
Latch-Up (V _{supply} overvoltage test) JESD78 compliant		≥ 5.4V

(8-pin plastic DFN 5mm × 6mm)

Test	DUT	Value
ESD HBM (Human Body Model) JESD22-A114 compliant	MB85RS2MTYPN-G-AWEWE1	$\geq 2000 \text{ V} $
ESD CDM (Charged Device Model) JESD22-C101		$\geq 750 \text{ V} $
Latch-Up (I-test) JESD78 compliant		$\geq 125\text{mA} $
Latch-Up (V_{supply} overvoltage test) JESD78 compliant		$\geq 5.4\text{V}$

■ REFLOW CONDITIONS AND FLOOR LIFE

[JEDEC MSL] : Moisture Sensitivity Level 3 (ISP/JEDEC J-STD-020D)

■ Current status on Contained Restricted Substances

This product complies with the regulations of REACH Regulations, EU RoHS Directive and China RoHS.

MB85RS2MTY

■ ORDERING INFORMATION

Part number	Package	Shipping form	Minimum shipping quantity
MB85RS2MTYPNF-G-AWE2	8-pin plastic SOP	Tube	— *
MB85RS2MTYPNF-G-AWERE2	8-pin plastic SOP	Embossed Carrier tape	1500
MB85RS2MTYPN-G-AWEWE1	8-pin plastic DFN	Embossed Carrier tape	1500

* : Please contact our sales office about minimum shipping quantity.

■ PACKAGE DIMENSION

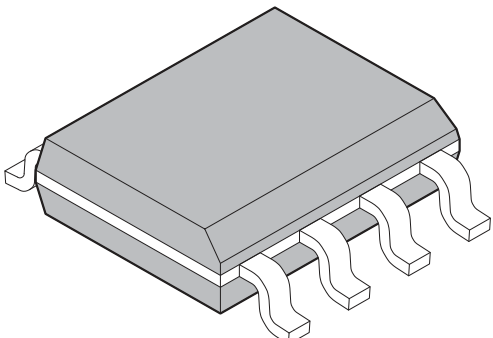
<p style="text-align: center;">8-pin plastic SOP</p> 	Lead pitch	1.27 mm	
	Package width package length	3.9 mm 4.9 mm	
	Lead shape	Gullwing	
	Sealing method	Plastic mold	
	Mounting height	1.75 mm MAX	

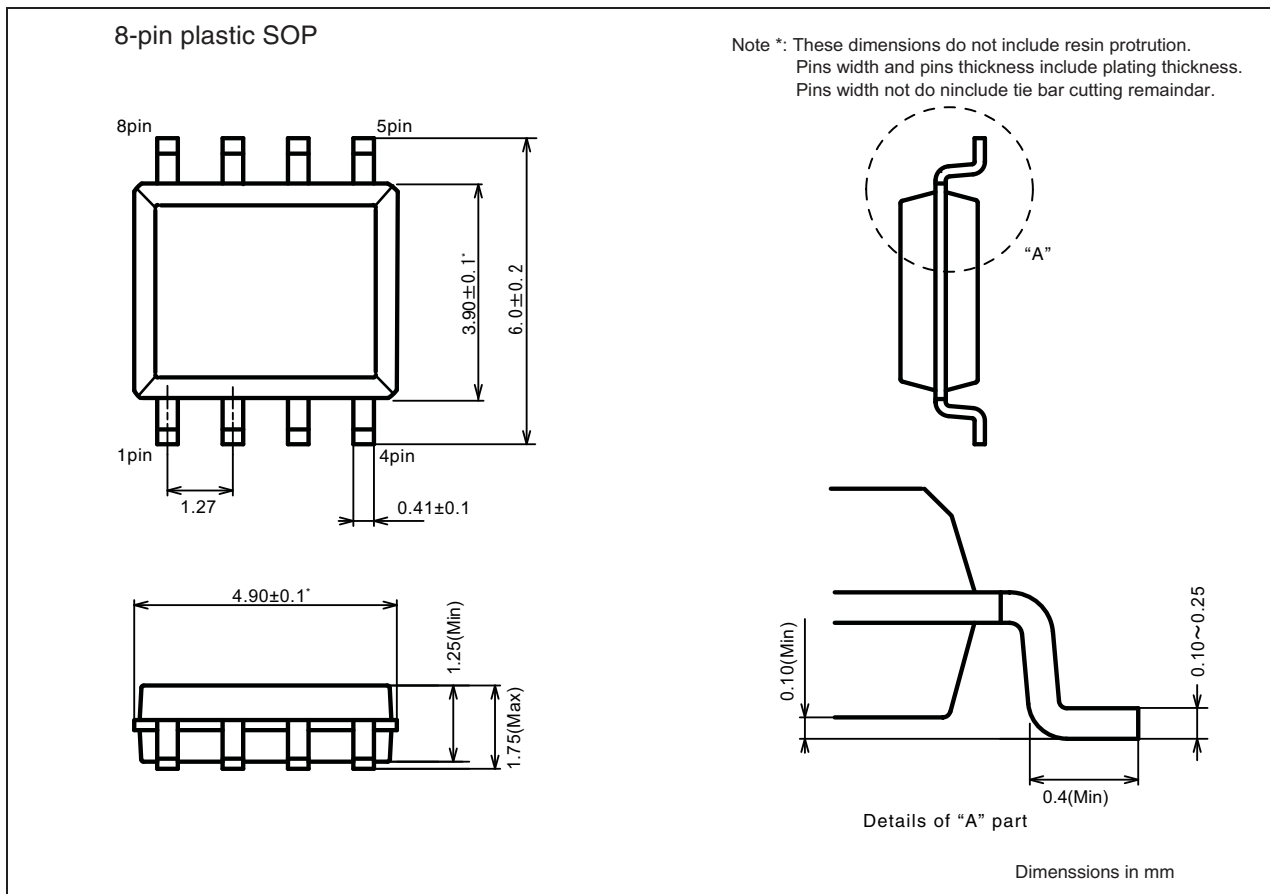

MB85RS2MTY

(Continued)

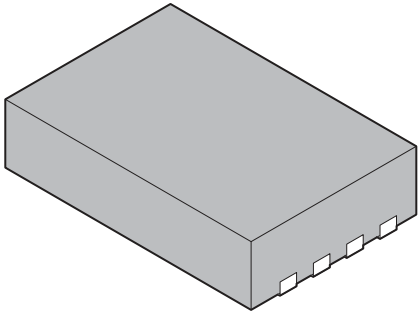
<p>8-pin plastic DFN</p> 	Lead pitch	1.27 mm
	Package width package length	5.0 mm 6.0 mm
	Sealing method	Plastic mold
	Mounting height	0.9 mm MAX

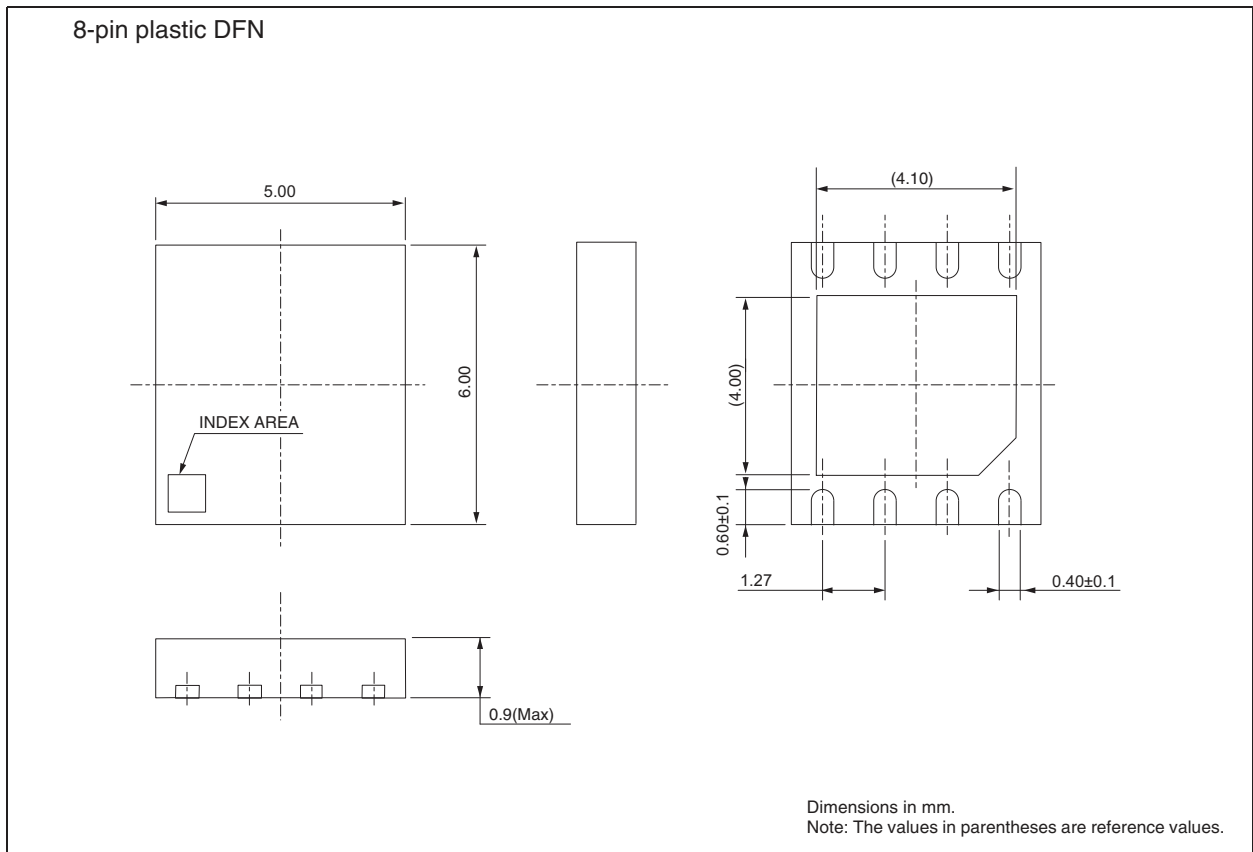

■ MARKING (Example)

[MB85RS2MTYPNF-G-AWE2]
[MB85RS2MTYPNF-G-AWERE2]

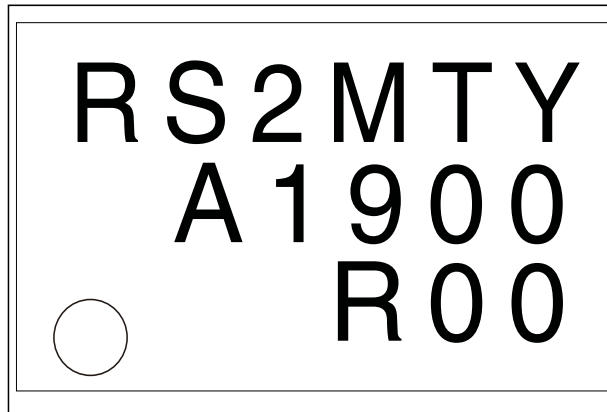

[8-pin plastic SOP 150mil]

RS2MTY: Product name
11900: 1(CS code) + 1900(Year and Week code)
R00: Trace code

[MB85RS2MTYPN-G-AWEWE1]

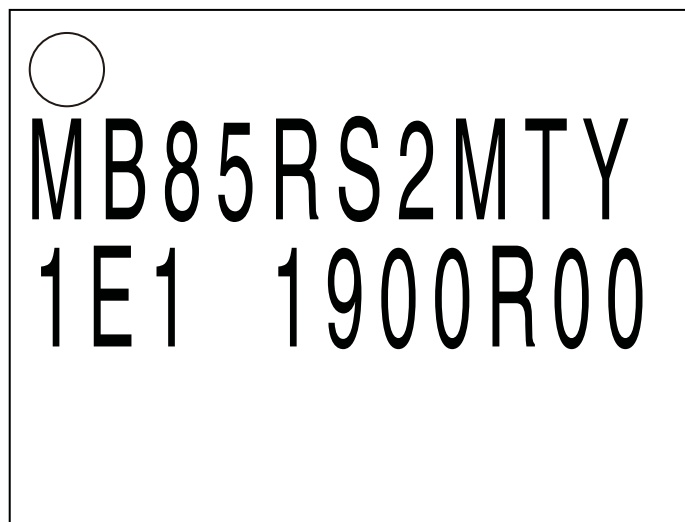

[8-pin plastic DFN 5mm × 6mm]

MB85RS2MTY: Product name
1E1: 1(CS code) + E1(Environmental code)
1900R00: 1900(Year and Week code) + R00(Trace code)

MB85RS2MTY

■ PACKING INFORMATION

1. Tube

1.1 Tube Dimensions

- Tube/stopper shape (example)

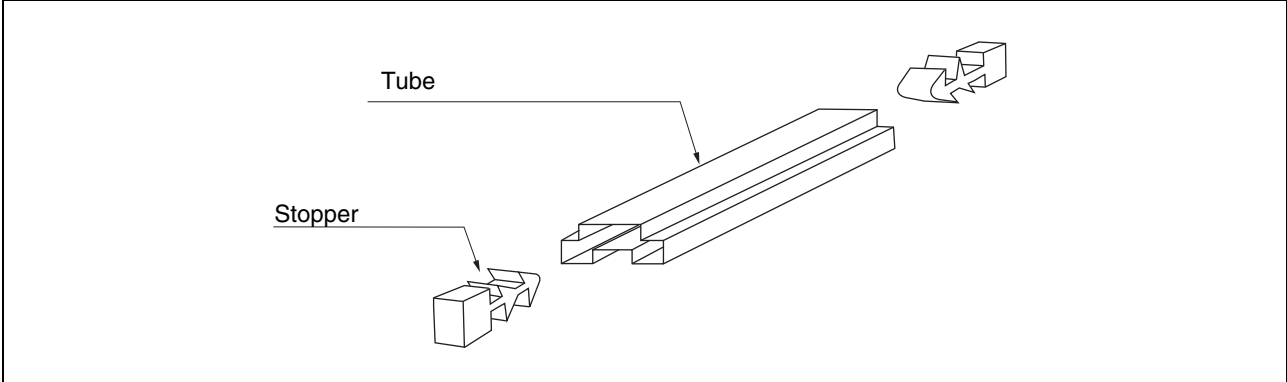

- Tube cross-sections and Maximum quantity

Maximum quantity		
pcs/tube(509mm)	pcs/inner box	pcs/outer box
85	4,250	25,500

No heat resistance.
Package should not be baked by using tube.

(Dimensions in mm)

- Direction of index in tube

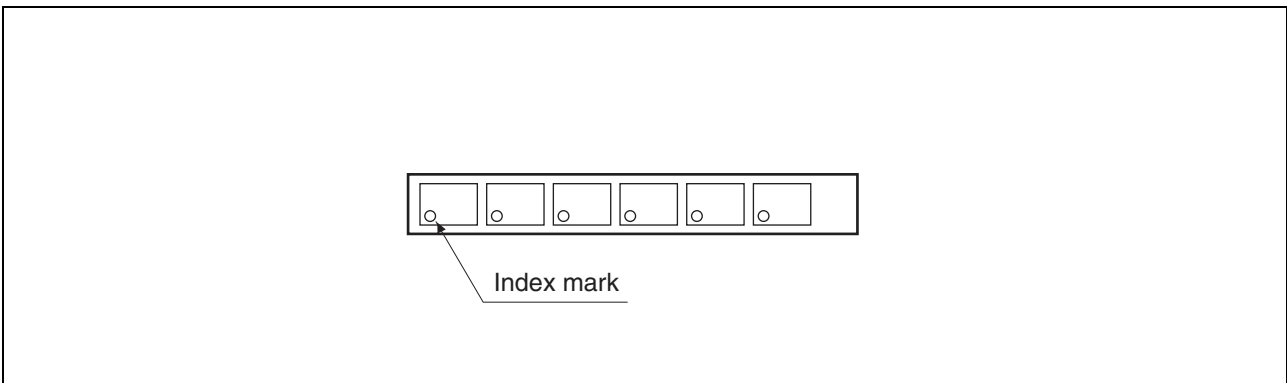

1.2 Product label indicators (example)

Label I: Label on Inner box/Moisture Barrier Bag/ (It sticks it on the reel for the emboss taping)
 [C-3 Label (50mm × 100mm) Supplemental Label (20mm × 100mm)]

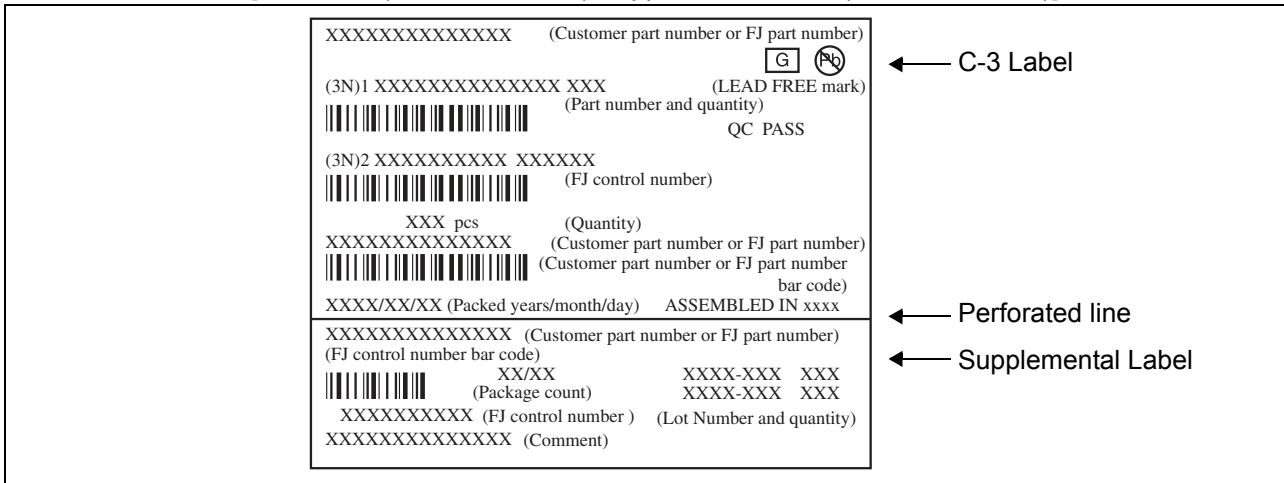

MB85RS2MTY

1.3 Dimensions for Containers

(1) Dimensions for inner box

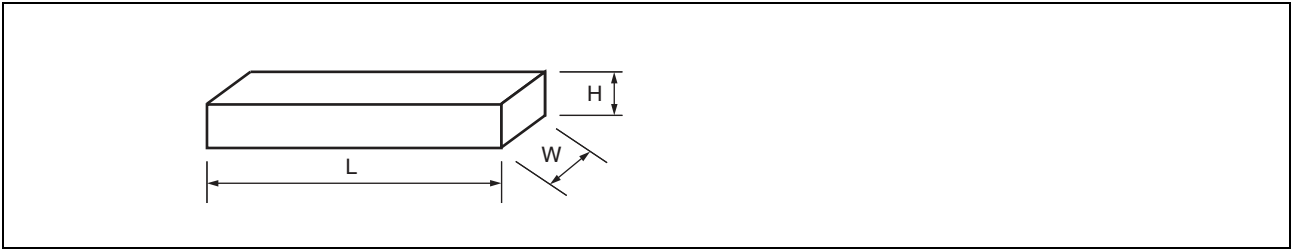

L	W	H
549	125	81

(Dimensions in mm)

(2) Dimensions for outer box

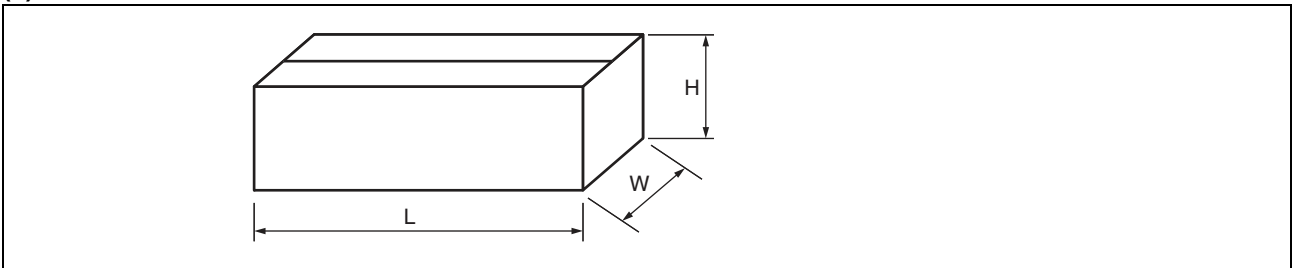

L	W	H
567	272	269

(Dimensions in mm)

2. Emboss Tape

2.1 Tape Dimensions (not drawn to scale)(8-pin plastic SOP 150mil)

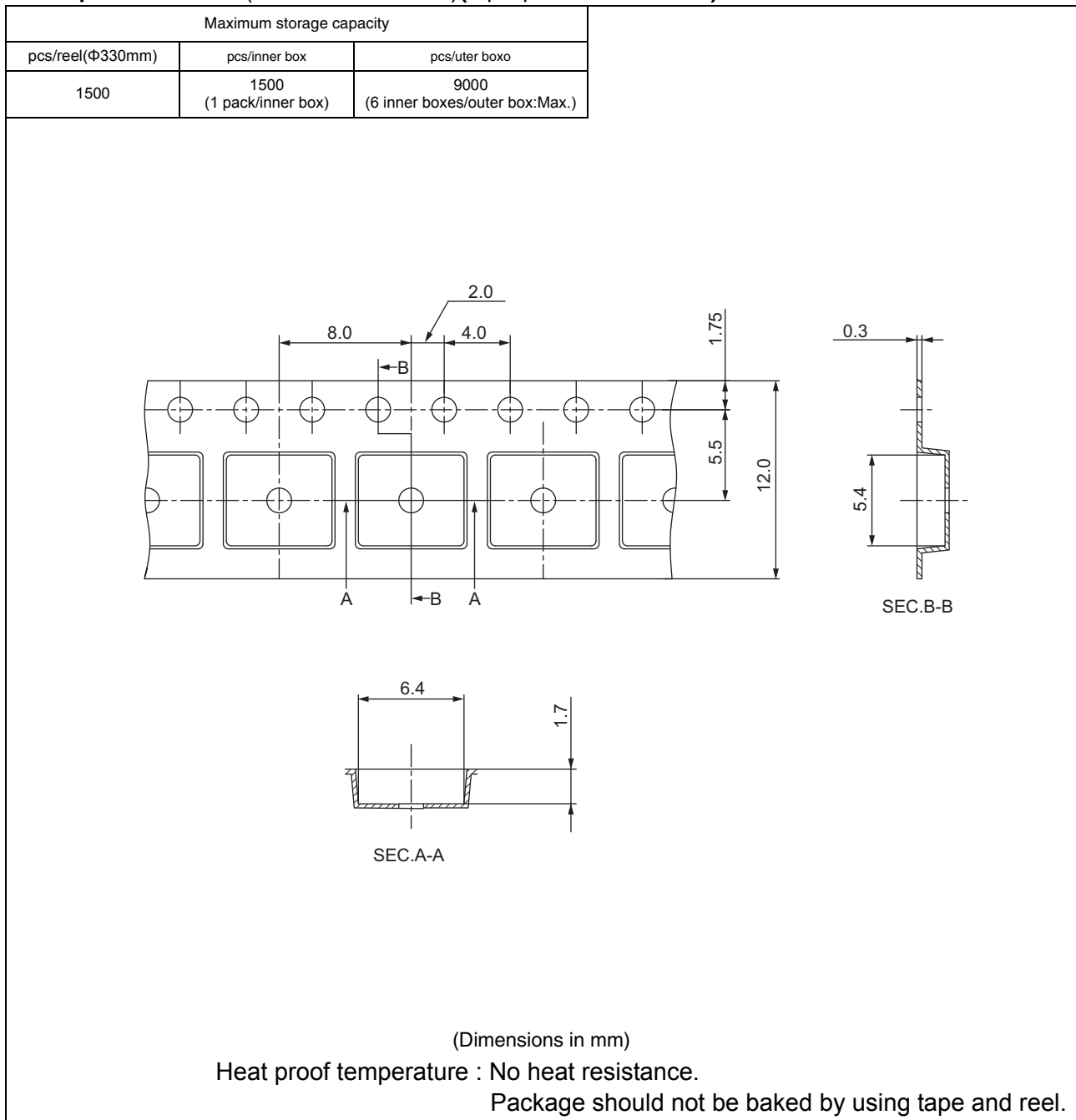

MB85RS2MTY

2.2 Tape Dimensions (not drawn to scale)(8-pin plastic DFN 5mm × 6mm)

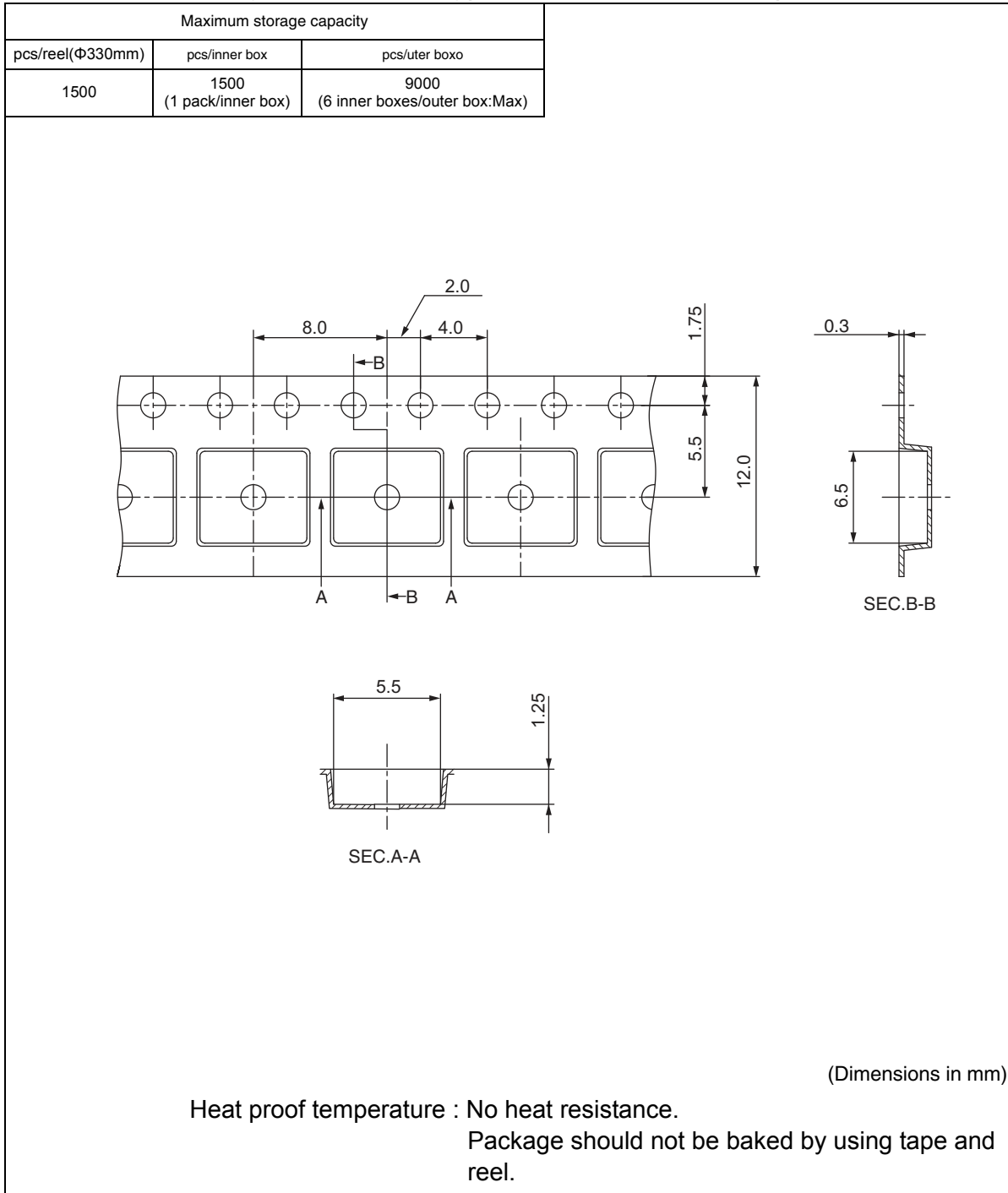

2.3 IC orientation

8-pin plastic SOP 150mil

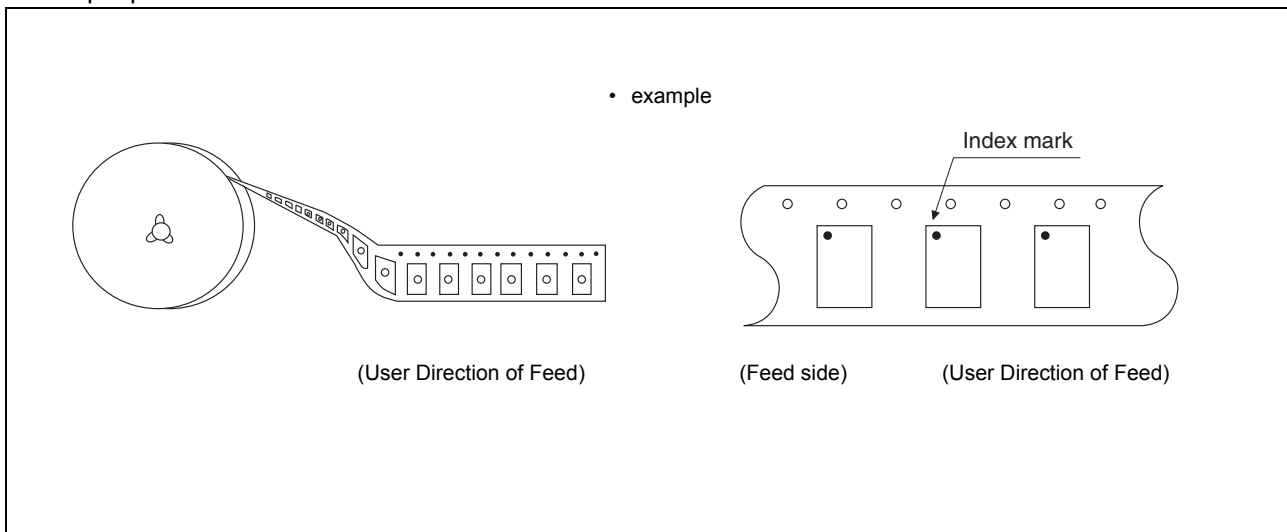

8-pin plastic DFN 5mm × 6mm

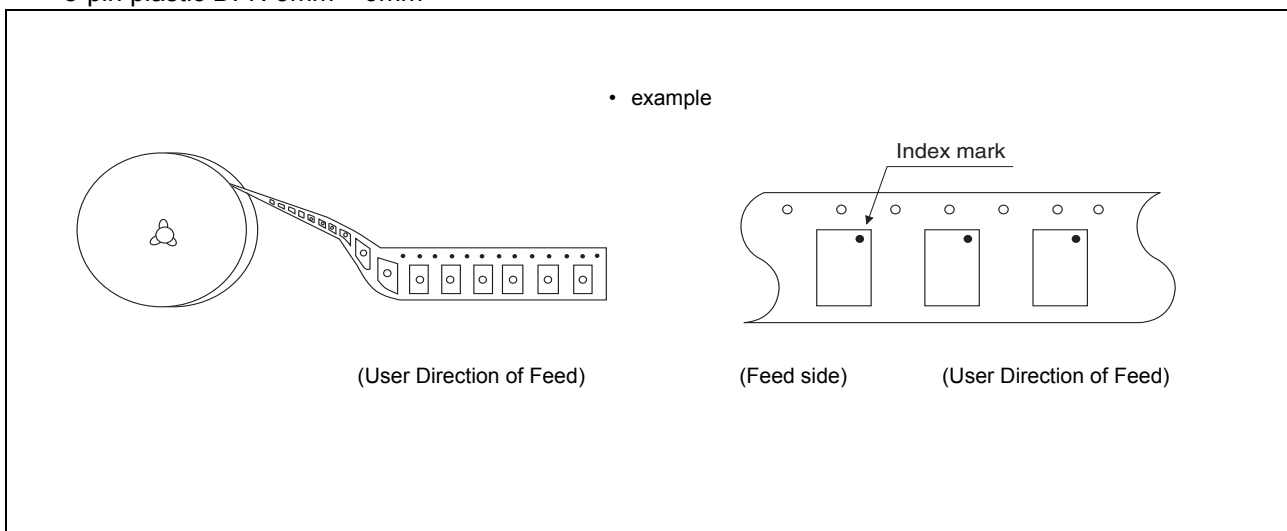

MB85RS2MTY

2.4 Reel dimensions

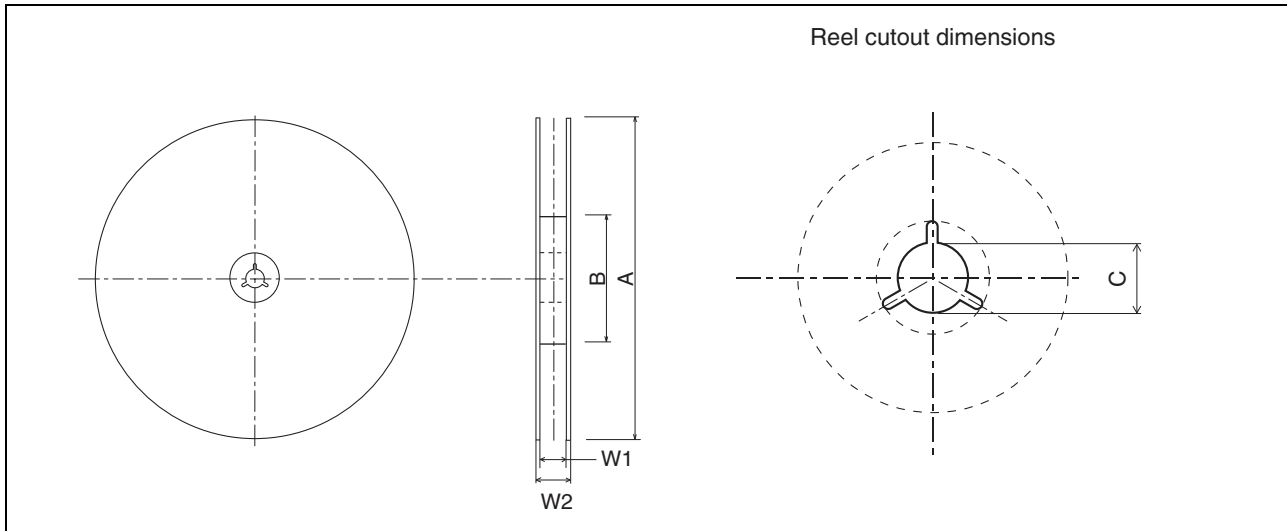



Dimensions in mm

A	B	C	W1	W2
300	100	13	13.5	17.5

2.5 Product label indicators (example)

Label I: Label on Inner box/Moisture Barrier Bag/ (It sticks it on the reel for the emboss tapping)
 [C-3 Label (50mm × 100mm) Supplemental Label (20mm × 100mm)]

XXXXXXXXXXXXXXXXX (Customer part number or FJ part number)	 	← C-3 Label
(3N)1 XXXXXXXXXXXXXXXXXX XXX (LEAD FREE mark) XXXXXXXXXXXXXXXXX (Part number and quantity)	QC PASS	
(3N)2 XXXXXXXXXXXXXXXXXX XXXXXX (FJ control number)		
XXX pcs (Quantity)		
XXXXXXXXXXXXXXXXX (Customer part number or FJ part number)		
XXXXXXXXXXXXXXXXX (Customer part number or FJ part number bar code)		← Perforated line
XXXX/XX/XX (Packed years/month/day) ASSEMBLED IN xxx		
XXXXXXXXXXXXXXXXX (Customer part number or FJ part number)		← Supplemental Label
XXXXXXXXXXXXXXXXX (FJ control number bar code)		
XX/XX (Package count)	XXXX-XXX XXX	
XXXXXXXXXXXX (FJ control number)	XXXX-XXX XXX	
XXXXXXXXXXXX (Lot Number and quantity)		
XXXXXXXXXXXXXXXXX (Comment)		

Label II: Moisture Barrier Bag (It sticks it on the Aluminum laminated bag)
 [MSL Label (100mm × 70mm)]

<p>MOISTURE-SENSITIVE DEVICES</p> <p>注意</p> <ol style="list-style-type: none"> ドライパック包装の保管期限は、24 ヶ月 (25°C/80%RH未満) です。 本製品の耐熱温度は、<u>260°C</u> です。 袋開封後は、下記a) b)条件下で、ご使用ください。 <ol style="list-style-type: none"> <u>168</u> 時間以内 (30°C/60%RH以下) J-STD-033条件 以下の条件の場合は、実装前にベークしてください。 <ol style="list-style-type: none"> 23±5°Cの環境下でインジケータカードの10%を超えた場合 3a、3bの条件に合致しない場合 ベーク必要な場合はIPC/JEDEC J-STD-033 参照してください。 <p>CAUTION</p> <ol style="list-style-type: none"> Calculated shelf life in sealed bag: 24 months at <25°C / 80% RH Peak package body temperature: <u>260°C</u> After bag is opened, devices that will be subjected to reflow solder or other high temperature process must <ol style="list-style-type: none"> Mounted within: <u>168</u> hours of factory conditions ≤30°C/60%RH Stored per J-STD-033 Devices require bake, before mounting, if: <ol style="list-style-type: none"> Humidity Indicator Card is > 10% when read at 23±5°C 3a or 3b not met. If baking is required, refer to IPC/JEDEC J-STD-033 for bake procedure. 	<p>LEVEL</p> <p>3</p> 	← MSL label
<p>包装日：品名ラベルをご確認下さい Bag Seal Date: See adjacent bar code label</p>	 * F 0 0 0 1 *	
<p>Note: Level and body temperature defined by IPC/JEDEC J-STD-020</p>		

MB85RS2MTY

2.6 Dimensions for Containers

(1) Dimensions for inner box

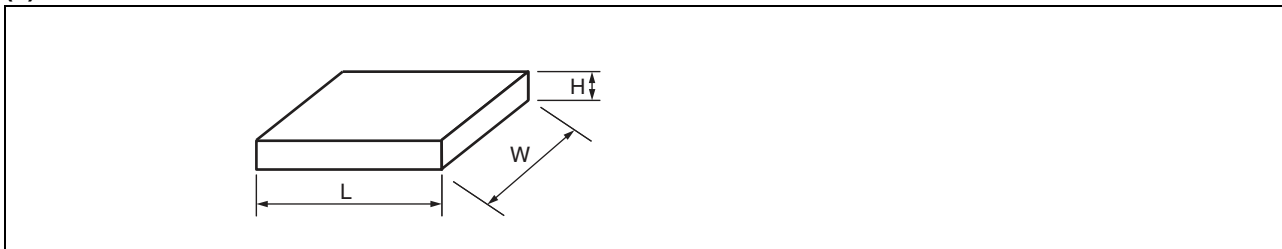

Tape width	L	W	H
12	350	335	35

(Dimensions in mm)

(2) Dimensions for outer box

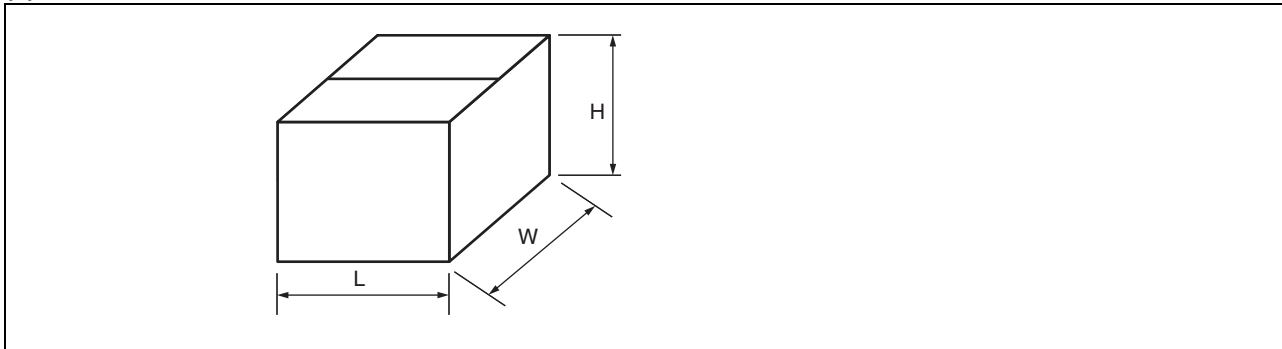

L	W	H
384	368	225

(Dimensions in mm)

FUJITSU SEMICONDUCTOR MEMORY SOLUTION LIMITED

Shin-Yokohama TECH Building, 3-9-1 Shin-Yokohama,
Kohoku-ku, Yokohama, Kanagawa 222-0033, Japan
<https://www.fujitsu.com/jp/fsm/en/>

All Rights Reserved.

FUJITSU SEMICONDUCTOR LIMITED, its subsidiaries and affiliates (collectively, "FUJITSU SEMICONDUCTOR") reserves the right to make changes to the information contained in this document without notice. Please contact your FUJITSU SEMICONDUCTOR sales representatives before order of FUJITSU SEMICONDUCTOR device.

Information contained in this document, such as descriptions of function and application circuit examples is presented solely for reference to examples of operations and uses of FUJITSU SEMICONDUCTOR device. FUJITSU SEMICONDUCTOR disclaims any and all warranties of any kind, whether express or implied, related to such information, including, without limitation, quality, accuracy, performance, proper operation of the device or non-infringement. If you develop equipment or product incorporating the FUJITSU SEMICONDUCTOR device based on such information, you must assume any responsibility or liability arising out of or in connection with such information or any use thereof. FUJITSU SEMICONDUCTOR assumes no responsibility or liability for any damages whatsoever arising out of or in connection with such information or any use thereof.

Nothing contained in this document shall be construed as granting or conferring any right under any patents, copyrights, or any other intellectual property rights of FUJITSU SEMICONDUCTOR or any third party by license or otherwise, express or implied.

FUJITSU SEMICONDUCTOR assumes no responsibility or liability for any infringement of any intellectual property rights or other rights of third parties resulting from or in connection with the information contained herein or use thereof.

The products described in this document are designed, developed and manufactured as contemplated for general use including without limitation, ordinary industrial use, general office use, personal use, and household use, but are not designed, developed and manufactured as contemplated (1) for use accompanying fatal risks or dangers that, unless extremely high levels of safety is secured, could lead directly to death, personal injury, severe physical damage or other loss (including, without limitation, use in nuclear facility, aircraft flight control system, air traffic control system, mass transport control system, medical life support system and military application), or (2) for use requiring extremely high level of reliability (including, without limitation, submersible repeater and artificial satellite). FUJITSU SEMICONDUCTOR shall not be liable for you and/or any third party for any claims or damages arising out of or in connection with above-mentioned uses of the products.

Any semiconductor devices fail or malfunction with some probability. You are responsible for providing adequate designs and safeguards against injury, damage or loss from such failures or malfunctions, by incorporating safety design measures into your facility, equipments and products such as redundancy, fire protection, and prevention of overcurrent levels and other abnormal operating conditions.

The products and technical information described in this document are subject to the Foreign Exchange and Foreign Trade Control Law of Japan, and may be subject to export or import laws or regulations in U.S. or other countries. You are responsible for ensuring compliance with such laws and regulations relating to export or re-export of the products and technical information described herein. All company names, brand names and trademarks herein are property of their respective owners.