



User Manual

PCM-9376

**AMD G-Series T16R 3.5" SBC,
DDR3 SODIMM, PC/104, 48-bit
LVDS, VGA, 18-bit TTL, 2GbE,
Mini PCIe, mSATA, LPC,
iManager**

ADVANTECH

Enabling an Intelligent Planet

Copyright

The documentation and the software included with this product are copyrighted 2014 by Advantech Co., Ltd. All rights are reserved. Advantech Co., Ltd. reserves the right to make improvements in the products described in this manual at any time without notice.

No part of this manual may be reproduced, copied, translated or transmitted in any form or by any means without the prior written permission of Advantech Co., Ltd. Information provided in this manual is intended to be accurate and reliable. However, Advantech Co., Ltd. assumes no responsibility for its use, nor for any infringements of the rights of third parties, which may result from its use.

Acknowledgements

AMI is a trademark of AMI Software International, Inc.

Intel® is a trademark of Intel® Technologies, Inc.

IBM, PC/AT, PS/2 and VGA are trademarks of International Business Machines Corporation.

Intel and Atom® are trademarks of Intel Corporation.

Microsoft Windows® is a registered trademark of Microsoft Corp.

RTL is a trademark of Realtek Semi-Conductor Co., Ltd.

ESS is a trademark of ESS Technology, Inc.

UMC is a trademark of United Microelectronics Corporation.

SMI is a trademark of Silicon Motion, Inc.

Creative is a trademark of Creative Technology LTD.

All other product names or trademarks are properties of their respective owners.

Product Warranty (2 years)

Advantech warrants to you, the original purchaser, that each of its products will be free from defects in materials and workmanship for two years from the date of purchase.

This warranty does not apply to any products which have been repaired or altered by persons other than repair personnel authorized by Advantech, or which have been subject to misuse, abuse, accident or improper installation. Advantech assumes no liability under the terms of this warranty as a consequence of such events.

Because of Advantech's high quality-control standards and rigorous testing, most of our customers never need to use our repair service. If an Advantech product is defective, it will be repaired or replaced at no charge during the warranty period. For out-of-warranty repairs, you will be billed according to the cost of replacement materials, service time and freight. Please consult your dealer for more details.

If you think you have a defective product, follow these steps:

1. Collect all the information about the problem encountered. (For example, CPU speed, Advantech products used, other hardware and software used, etc.) Note anything abnormal and list any onscreen messages you get when the problem occurs.
2. Call your dealer and describe the problem. Please have your manual, product, and any helpful information readily available.
3. If your product is diagnosed as defective, obtain an RMA (return merchandise authorization) number from your dealer. This allows us to process your return more quickly.
4. Carefully pack the defective product, a fully-completed Repair and Replacement Order Card and a photocopy proof of purchase date (such as your sales receipt) in a shippable container. A product returned without proof of the purchase date is not eligible for warranty service.
5. Write the RMA number visibly on the outside of the package and ship it prepaid to your dealer.

Technical Support and Assistance

1. Visit the Advantech web site at <http://support.advantech.com> where you can find the latest information about the product.
2. Contact your distributor, sales representative, or Advantech's customer service center for technical support if you need additional assistance. Please have the following information ready before you call:
 - Product name and serial number
 - Description of your peripheral attachments
 - Description of your software (operating system, version, application software, etc.)
 - A complete description of the problem
 - The exact wording of any error messages

Packing List

Before installation, please ensure the following items have been shipped:

Item Part Number

- 1 PCM-9376 SBC
- 1 Startup manual
- 1 Pack of mini jumper
- Cables

Part Number	Description
1700019414	COM2 cable 2*5P-2.0/D-SUB, 30cm
1701200220	COM3/4 cable 2*10P-2.0/D-SUB*2, 22cm
1700017863	LAN2 cable 2*5P-2.0/RJ45, 15cm
1700019071	USB cable 2*5P-2.0/USB*2 w/o bracket, 12cm
1700008941	SATA cable 7P/7P w/ lock, 32cm
1700018785	5V/12V SATA Power cable 4P-2.5/SATA 15P, 35cm
1703100152	Audio cable 2*5P-2.0/Jack*3, 20cm
1700060202	PS/2 cable M-DIN 6P/M-DIN 6P*2, 20cm

- Thermal solution:

Part Number	Description
1960060631T001	Heatsink 134 x 6.9 x 19.5 mm

Ordering Information

Model P/N	Memory	LVDS	TTL	Operating Temp
PCM-9376E-M0A1E	SODIMM	48-bit	-	0 ~ 60° C
PCM-9376F-M0A1E	SODIMM	-	18-bit	0 ~ 60° C
PCM-9376EZ-M0A1E	SODIMM	48-bit	-	-20 ~ 80° C
PCM-9376EZ2-M0A1E	SODIMM	48-bit	-	-40 ~ 85° C

Optional Accessories

P/N	Description
1703200201	ATX Power cable, 20 cm
1700018259	5V SATA Power cable 2P-2.0/SATA 15P, 20 cm
TBC	Heat spreader
PCA-COM232-00A1E	4 RS-232 LPC extension module, 31.5 x 48 mm
PCA-COM485-00A1E	4 RS-422/485 LPC extension module, 31.5 x 48 mm
PCA-TPM-00A1E	LPC extension TPM module, 31.5 x 48 mm

Certification and Safety Instructions

This device complies with the requirements in part 15 of the FCC rules: Operation is subject to the following two conditions:

1. This device may not cause harmful interference, and
2. This device must accept any interference received, including interference that may cause undesired operation

This equipment has been tested and found to comply with the limits for a Class A digital device, pursuant to Part 15 of the FCC Rules. These limits are designed to provide reasonable protection against harmful interference when the equipment is operated in a commercial environment. This equipment generates, uses, and can radiate radio frequency energy and, if not installed and used in accordance with the instruction manual, may cause harmful interference to radio communications. Operation of this device in a residential area is likely to cause harmful interference in which case the user will be required to correct the interference at his/her own expense. The user is advised that any equipment changes or modifications not expressly approved by the party responsible for compliance would void the compliance to FCC regulations and therefore, the user's authority to operate the equipment.

Caution! *There is a danger of a new battery exploding if it is incorrectly installed. Do not attempt to recharge, force open, or heat the battery. Replace the battery only with the same or equivalent type recommended by the manufacturer. Discard used batteries according to the manufacturer's instructions.*



Contents

Chapter 1	General Introduction	1
1.1	Introduction	2
1.2	Specifications	2
1.2.1	Functional Specifications	2
1.2.2	Mechanical Specifications	4
1.2.3	Electrical Specifications	4
1.3	Environmental Specifications	4
1.4	Block Diagram	4
	Figure 1.1 Block Diagram	4
Chapter 2	H/W Installation.....	7
2.1	Jumpers	8
2.1.1	Jumper Description	8
2.1.2	Jumper List	8
	Table 2.1: Jumper List	8
2.1.3	Jumper Settings	9
2.2	Connectors	10
2.2.1	Connector List.....	10
	Table 2.2: Connector List	10
2.2.2	Connector Settings	10
2.3	Mechanical	13
2.3.1	Jumper and Connector Locations	13
	Figure 2.1 Jumper and Connector Layout (Top Side)	13
	Figure 2.2 Jumper and Connector Layout (Bottom Side)	13
	Figure 2.3 Coastline Layout.....	14
2.3.2	Board Dimensions.....	14
	Figure 2.4 Board Dimension Layout (Top Side)	14
	Figure 2.5 Board Dimension Layout (Bottom Side)	14
	Figure 2.6 Board Dimension Layout (Coastline).....	15
Chapter 3	BIOS Settings.....	17
3.1	Introduction	18
	Figure 3.1 Setup Program Initial Screen.....	18
3.2	Entering Setup	19
3.3	Main Setup	19
3.3.1	System Time / System Date	19
3.4	Advanced BIOS Features Setup	20
3.4.1	PCI Subsystem Settings Configuration	21
3.4.2	ACPI Settings Configuration	22
3.4.3	S5 RTC Wake Settings	23
3.4.4	Trusted Computing	24
3.4.5	CPU Configuration	25
3.4.6	IDE Configuration.....	26
3.4.7	USB Configuration	27
3.4.8	Embedded Controller Configuration.....	28
3.4.9	Super I/O Configuration	29
3.4.10	IT8888 Configuration	30
3.5	Chipset Configuration.....	31
3.5.1	North Bridge Configuration	32
3.5.2	North Bridge LVDS Config Select.....	33
3.5.3	South Bridge	34

3.6	Boot Settings.....	35
3.7	Security Configuration.....	36
3.8	Save & Exit	37

Appendix A Pin Assignments 39

A.1	Jumper Setting.....	40
	Table A.1: Jumper List.....	40
A.2	Connectors.....	40
	Table A.2: Connector List	40

Appendix B System Assignment..... 59

B.1	System I/O Ports.....	60
	Table B.1: System I/O Ports	60
B.2	1st MB Memory Map.....	61
	Table B.2: 1st MB Memory Map	61
B.3	Interrupt Assignments	61
	Table B.3: Interrupt Assignments	61

Appendix C Watchdog Timer Programming 63

C.1	EC Watchdog Timer Sample Code.....	64
-----	------------------------------------	----

Chapter 1

General Introduction

This chapter gives background information on the PCM-9376.

Sections include:

- Introduction
- Product Features
- Specifications

1.1 Introduction

AMD G-Series T16R single core 615 MHz processor. The PCM-9376 can support DDR3 SODIMM up to 4 GB or 1 GB SDRAM on-board, PC/104, Mini PCIe and LPC (Low Pin Count) expansion, VGA, 48-bit LVDS, 18-bit TTL, 2 GbE, 2 SATAII, mSATA, 2 RS-232/422/485, 2 RS-232, 4 USB2.0, SMBus, I²C, 8-bit GPIO, PS/2. 5V AT/ATX supported.

1.2 Specifications

1.2.1 Functional Specifications

APU: AMD G-Series T16R

- Single core 615 MHz
- Supports sleep states including S0, S3, S4 and S5 (but USB ports are not supported S3)
- AMD64 64-bit ISA

System Memory Support

- SODIMM: Up to DDRIII 1066 MHz
- SDRAM on-board: 1 GB DDRIII 800MHz (Supported by T-P/N)

Graphic/Display

- **Discrete Class Graphics:** AMD Radeon™ HD 6250
- **GPU Core Frequency:** 276MHz
- 384MB Video RAM shared with system memory
- **2D Acceleration:** Highly-optimized 128-bit engine
- **3D Acceleration:**
 - Full DirectX® 11 support, including full speed 32-bit floating point per component operations
 - Shader Model 5
 - OpenCL™ 1.1 support
 - OpenGL 4.0 support
- **Motion Video Acceleration:**
 - Dedicated hardware (UVD 3) for H.264, VC-1 and MPEG2 decode
 - HD HQV and SD HQV support
- Support Extend and Clone mode under dual display
- Display interfaces: VGA, LVDS and TTL (Dual display supported for any two combination)
 - VGA: analog RGB display output up to resolution 1920x1200 at 85Hz
 - LVDS: 48-bit LVDS up to 1920x1200 at 60Hz (PCM-9376E)
 - TTL: 18-bit TTL up to 1024x600 at 60Hz (PCM-9376F)

Gigabit Ethernet

- **Controller:** Realtek RTL8111E-VL-CG
- 10/100/1000 Mb/s Ethernet, supporting wake on LAN
- Support Jumbo Frame to 9K bytes
- Supports IEEE 802.3, IEEE 802.3u, IEEE 802.ab

Peripheral Interface

- **PC/104 expansion:** Fully ISA supported. If user needs booting/power from PC/104, supported by T-P/N)
- **LPC connector:**
 - Controller: ITE 8760E
 - LPC module: PCA-COM232-00A1E (4 RS-232 ports), PCA-COM485-00A1E (4 RS-422/485 ports), and PCA-TPM-00A1E.
 - Not support 5 Vsb
- 2 Serial-ATA ports, up to 3.0Gb/s (300 MB/s)
- 1 full-size mSATA slot, with USB interface (PCIe interface supported by T-P/N)
- 1 half-size Mini PCIe slot, with PCIe and USB interface
- 4 USB 2.0 compliant ports
- 2 RS-232 from COM3/4, 2 RS-232/422/485 from COM1/2 (ESD protection: air gap ± 15 kV, contact ± 8 kV), support RS-485 auto flow control
- SMBus or I²C (auto detection by iManager)
- Support standard PC/AT keyboard and PS/2 mouse
- 8-bit programmable GPIO (General Purpose Input/Output) with 5V tolerance
- 1 Reset button
- **Watchdog timer:** 255 levels timer interval, programmable by software, multi-level WDT (set by iManager)
- **Audio:** Realtek ALC892, High Definition Audio, Line-in, Line-out, Mic-in

BIOS

- AMI 32 Mbit SPI Flash ROM

OS Support

PCM-9376 supports Win7, WinXP, WinCE 6.0, WEC7, WES7, XPE and Linux Ubuntu 12.04.

For further information about OS support, please visit Advantech website: www.advantech.com or contact with technical support center.

iManager

- **Power Sequence:** Control by iManager
- **Power Saving:**
 - Deep sleep mode
 - Backlight control
 - Brightness control
- **Hardware Monitor:**
 - Battery voltage
 - Read CPU temperature
 - 5 V, 12 V, Vcore
- **Multi-control Interface:** GPIO, SMBus or I²C
- **Watchdog Timer:** Output system reset, programmable counter from 1-255 min/sec (set by iManager)
- **Board Information:**
 - Running hour
 - Booting record
- **Security data area:** 64 bytes on EEPROM for customer saving sensitive data

1.2.2 Mechanical Specifications

- **Dimensions:** 146 x 102 mm (5.7" x 4")
- **Height:**
 - Total: 23.9 mm
 - Top side: 15.5 mm (PCB top to heatsink)
 - Bottom side: 6.8 mm (PCB bottom to Mini PCIe slot)
- **Reference Weight:** 500 g (including whole package)

1.2.3 Electrical Specifications

- **Power supply type:** AT / ATX
- **Power management:** ACPI
- **Power requirement:** +5 V \pm 5% (+12 V optional for PC/104 add-on module and LCD inverter)
 - AT: +5 V \pm 5%
 - ATX: +5 V \pm 5%, +5 Vsb
- **RTC battery:**
 - Typical voltage: 3.0 V
 - Normal discharge capacity: 210 mAh

1.3 Environmental Specifications

- **Operating temperature:** 0 ~ 60° C (32 ~ 140° F)
- **Operating humidity:** 40° C @ 95% RH Non-condensing
- **Storage temperature:** -40 ~ 85° C (-40 ~ 185° F)
- **Storage humidity:** 60° C @ 95% RH Non-condensing

1.4 Block Diagram

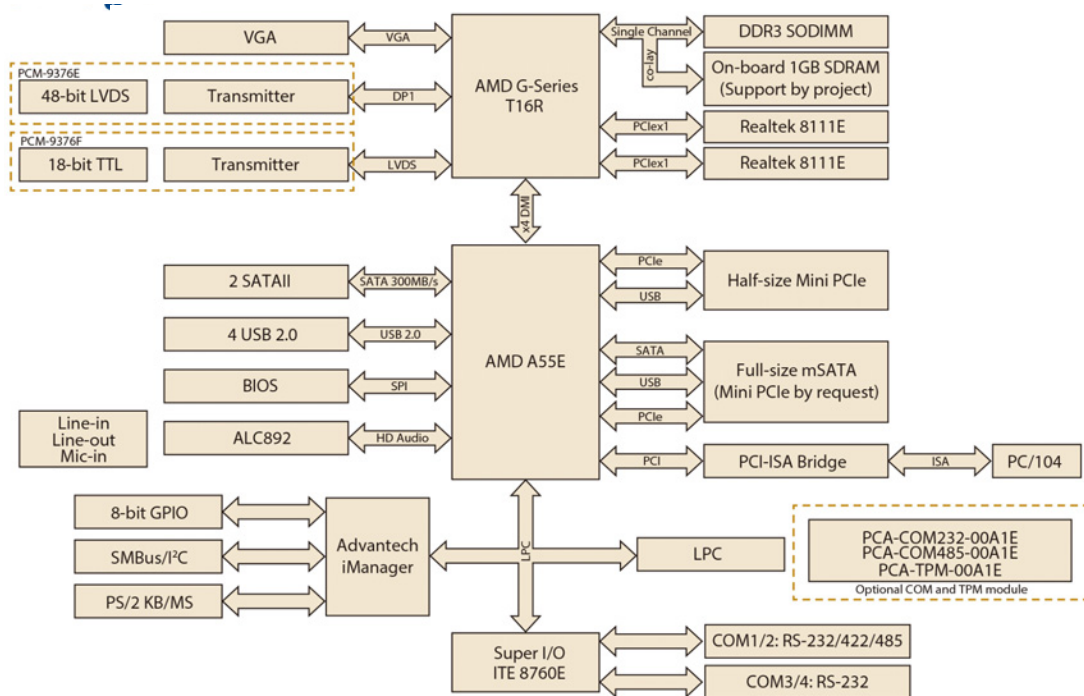

Figure 1.1 Block Diagram

Chapter 2

H/W Installation

This chapter explains the setup procedures of the PCM-9376 hardware, including instructions on setting jumpers and connecting peripherals, as well as switches, indicators and mechanical drawings. Be sure to read all safety precautions before you begin the installation procedure.

2.1 Jumpers

2.1.1 Jumper Description

Cards can be configured by setting jumpers. A jumper is a metal bridge used to close an electric circuit. It consists of two metal pins and a small metal clip (often protected by a plastic cover) that slides over the pins to connect them. To close a jumper, you connect the pins with the clip. To open a jumper, you remove the clip. Sometimes a jumper will have three pins, labeled 1, 2 and 3. In this case you would connect either pins 1 and 2, or 2 and 3.

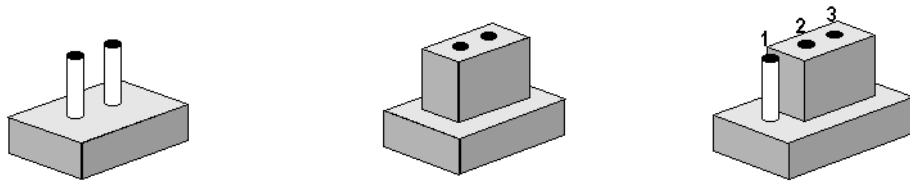

The jumper settings are schematically depicted in this manual as follows.



A pair of needle-nose pliers may be helpful when working with jumpers. If you have any doubts about the best hardware configuration for your application, contact your local distributor or sales representative before you make any changes.

Generally, you simply need a standard cable to make most connections.

Warning! To avoid damaging the computer, always turn off the power supply before setting jumpers.



2.1.2 Jumper List

Table 2.1: Jumper List

J1	AT/ATX power supply
J2	LCD Power
J3	Clear CMOS

2.1.3 Jumper Settings

J1	AT/ATX power supply
Part Number	1653002101
Footprint	HD_2x1P_79_D
Description	PIN HEADER 2*1P 180D(M)SQUARE 2.0mm DIP W/O Pb
Setting	Function
NC	ATX
(1-2)*	AT
*: default	

J2	LCD Power
Part Number	1653003201
Footprint	HD_3x2P_79_D
Description	PIN HEADER 3x2P 2.0mm 180D(M) SMD 21N22050
Setting	Function
(1-3)*	+3.3 V
(3-5)	+5 V
(3-4)	+12 V
*: default	

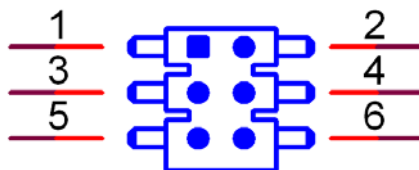

J3	Clear CMOS
Part Number	1653003101
Footprint	HD_3x1P_79_D
Description	PIN HEADER 3x1P 2.0mm 180D(M) DIP 2000-13 WS
Setting	Function
(1-2)*	* Normal
(2-3)	Clear COMS
*: default	

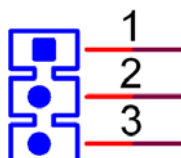

2.2 Connectors

2.2.1 Connector List

Table 2.2: Connector List	
CN2	PC/104 -5/-12V power input
CN5	SATA
CN6	2 x Internal USB
CN7	2 x Internal USB
CN8	Internal COM3/4: RS-232
CN9	Internal COM2: RS-232/422/485
CN10	GPIO
CN11	Audio
CN12	Power input
CN13	SATA
CN14	ATX standby power input
CN15	SMBus / I ² C
CN16	PC/104
CN17	TTL
CN18	Inverter power
CN19	SATA power (5V/12V)
CN20	SATA power (5V)
CN21	Internal GbE
CN22	LVDS
CN23	External GbE
CN24	PS/2
CN25	Power Switch
CN26	External COM1: RS-232/422/485
CN27	VGA
CN28	Half-size Mini-PCIe
CN29	LPC
CN30	Full-size mSATA
CN31	DDR3 SODIMM

2.2.2 Connector Settings

2.2.2.1 RTC Battery Connector (BH1)

Removing battery will clear CMOS.

2.2.2.2 PC/104 -5/-12 V Power Input (CN2)

Supplies main power +5 V to PCM-9376 via 6 x 2-pin connector, and to devices that require +12 V. AT power cable is included in standard packing, but ATX power cable (P/N: 1703200201) is an optional accessory requiring additional order.

2.2.2.3 SATA (CN5/13)

PCM-9376 features two high performance Serial ATA interface (up to 300 MB/s) via standard SATA 7-pin connectors.

2.2.2.4 2 x Internal USB (CN6/7)

PCM-9376 provides four USB (Universal Serial Bus) 2.0 ports Plug and Play via 5 x 2-pin header connectors which provide 1 A power for each port. The USB interface complies with high speed USB specification Rev. 2.0 which supports 480 Mbps transfer rate, and are fuse protected.

Note! Due to 5 V power connector type's limitation, USB ports don't support ACPI and S3 wake-up.



2.2.2.5 Serial Ports (CN8/9/26)

PCM-9376 provides four serial ports: two RS-232 ports (COM3/4) and two RS-232/422/485 (COM1/2). It provides connections for serial devices or communication network.

- COM1: RS-232/422/485 (CN26)
Connector: standard 9-pin D-SUB at coastline, selecting by BIOS settings.
- COM2: RS-232/422/485 (CN9)
Connector: 5x2-pin box header, selecting by BIOS settings.
- COM3/4: RS-232 (CN8)
Connector: 10 x 2-pin box header

2.2.2.6 GPIO (CN10)

PCM-9376 supports 8-bit GPIO (5 V tolerance) through this 5x2-pin box header connector, controlled by iManager.

The 8 digital inputs and outputs can be programmed to read or control devices, with each input or output defined.

2.2.2.7 Audio (CN11)

High Definition audio with Realtek ALC892 codec via 5x2-pin box header connector, supporting line-in/ line-out/ mic-in output.

2.2.2.8 Power Input (CN12)

Supplies main power +5 V to PCM-9376 via 1x4-pin connector, and to devices that require +12 V.

AT power cable is included in standard packing, but ATX power cable (P/N: 1703200201) is an optional accessory requiring additional order.

2.2.2.9 ATX Standby Power Input (CN14)

The 3-pin wafer box connector provides PS on, can be used by ATX power cable (P/N: 1703200201)

2.2.2.10 SMBus / I²C (CN15)

PCM-9376 provides 4-pin wafer connector with 5 V@ 0.3 A power for customer connecting to SMBus or I²C protocol embedded device (auto detection by iManager). Advantech also provides SMBus API allowing developer to interface with an embedded system environment and transfer serial messages using the SMBus protocols, allowing multiple simultaneous device control.

2.2.2.11 PC/104 (CN16)

Standard 104-pin PC/104 short pin connector which provides 1 A power for 8/16-bit ISA. If user needs to boot up from PC/104 or with long pin PC/104, that can be supported by T-P/N.

2.2.2.12 TTL (CN17)

The TTL interface is a 20 x 2-pin board-to-board connector which provides 1A power for 18-bit TTL panel.

2.2.2.13 Inverter Power (CN18)

LCD inverter is connected to this 5-pin box wafer connector to provide +5 V @ 1 A / +12 V @ 0.5 A power.

2.2.2.14 SATA Power: 5/12 V (CN19)

4-pin wafer box connector is provided 5V@1A / 12V@0.5A power, corresponding cable P/N is 1700018785.

2.2.2.15 SATA Power: 5 V (CN20)

Another 5V SATA power is provided 1 A via 2-pin wafer box, optional cable (P/N: 1700018259) can be ordered additionally.

2.2.2.16 GbE (CN21/23)

- **Connector:** GbE1 at coastline, GbE2 is 5x2-pin box header
- **Controller:** Realtek 8111E-VL-CG

2.2.2.17 LVDS (CN22)

The LVDS interface is a 20 x 2-pin board-to-board connector for 48-bit LVDS panel up to 1920 x 1200 at 60 Hz which provides 3.3/5/12V with 1A power.

2.2.2.18 PS/2 (CN24)

PCM-9376 provides a standard mini din 6-pin connector that supports both keyboard and PS/2 interface mouse.

2.2.2.19 ATX Power Button (CN25)

2-pin box wafer connector for power switch.

2.2.2.20 VGA (CN27)

The VGA interface is a standard 15-pin D-SUB connector as coastline for conventional CRT display.

Resolution: 1920 x 1200 at 85Hz

2.2.2.21 Half-size Mini-PCle (CN28)

Half-size Mini-PCle is with PCIe and USB signal interface which provides 3.3 V @ 0.75 A / 3.3 Vsb @ 0.25 A / 1.5 V @ 0.375 A.

2.2.2.22 LPC (CN29)

Advantech provides three LPC modules to choose: PCA-COM232-00A1E, PCACOM485-00A1E and PCA-TPM-00A1E (standard BIOS can support already).

If using other LPC module, BIOS modification is needed.

Connector: 7x2-pin female header

2.2.2.23 Full-size mSATA (CN30)

Full-size mSATA slot is with SATA and USB interface which provides 3.3 V @ 0.75 A / 1.5 V @ 0.375 A, can support PCIe interface by T-P/N.

2.2.2.24 DDR3 SODIMM (CN31)

One 204-pin DDR3 SODIMM socket supports DDRIII 1066 MHz up to 4 GB.

2.2.2.25 Reset Button

Momentarily pressing the button will activate a reset.

2.3 Mechanical

2.3.1 Jumper and Connector Locations

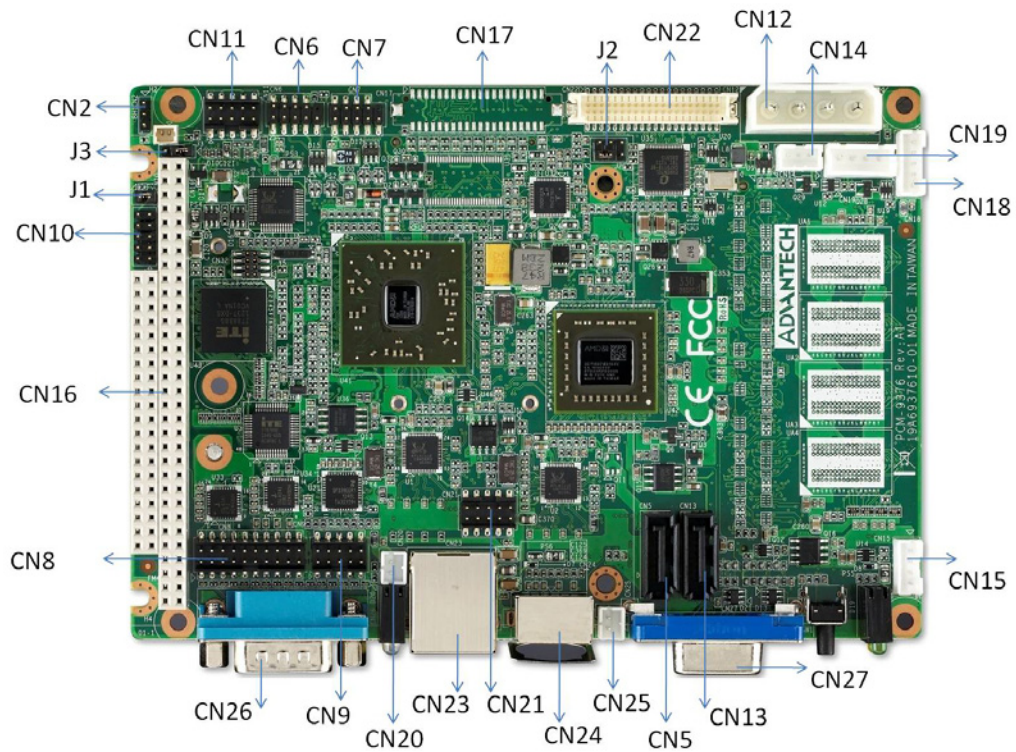

Figure 2.1 Jumper and Connector Layout (Top Side)

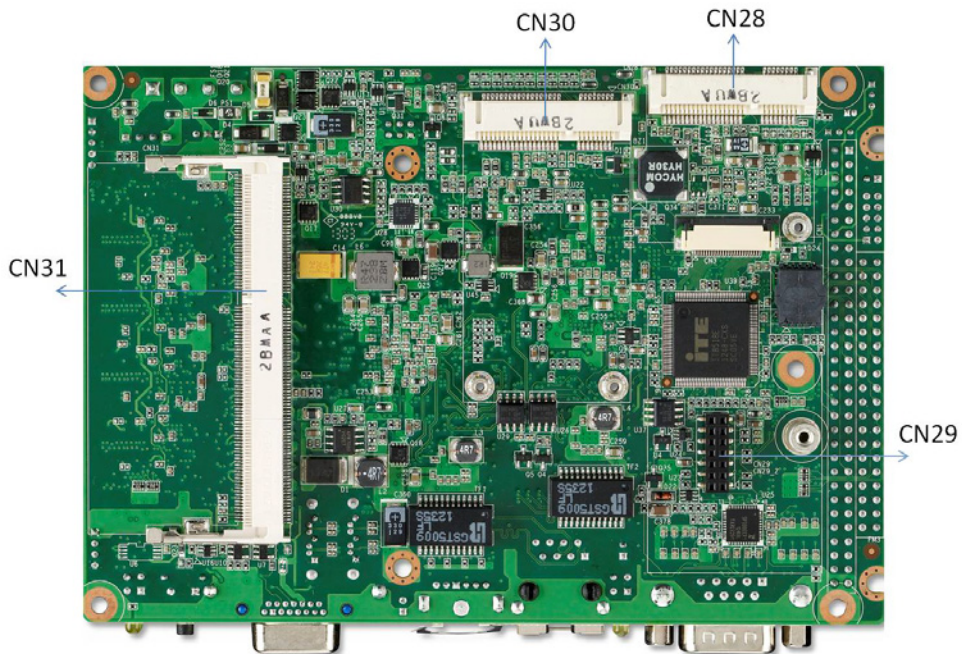

Figure 2.2 Jumper and Connector Layout (Bottom Side)

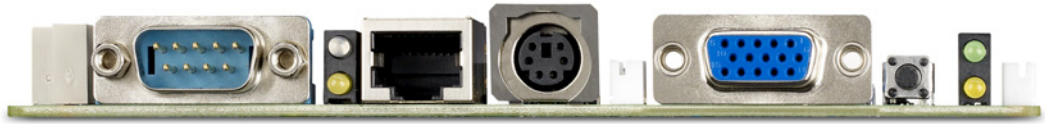

Figure 2.3 Coastline Layout

2.3.2 Board Dimensions

2.3.2.1 CPU Board Drawing

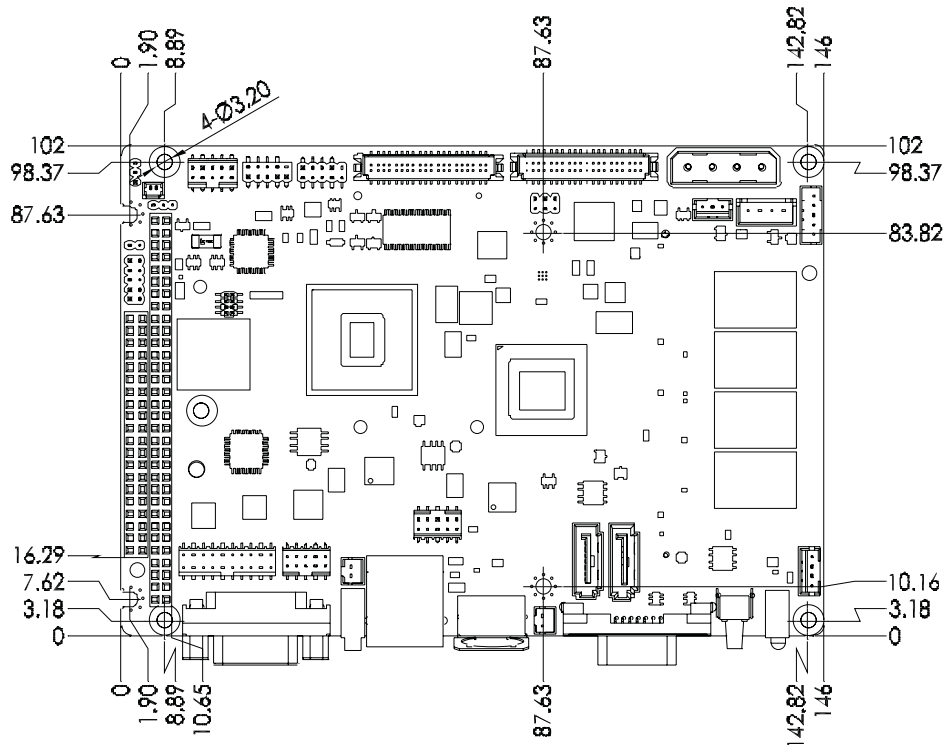

Figure 2.4 Board Dimension Layout (Top Side)

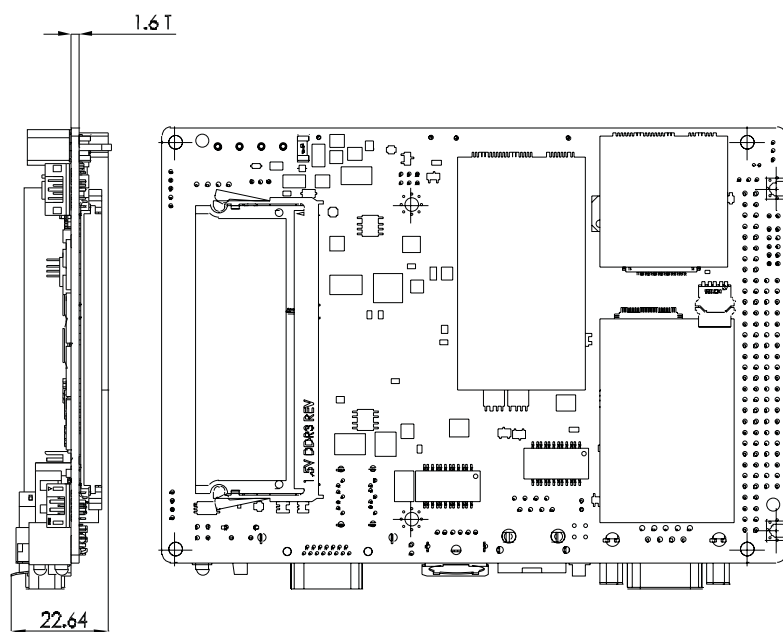

Figure 2.5 Board Dimension Layout (Bottom Side)

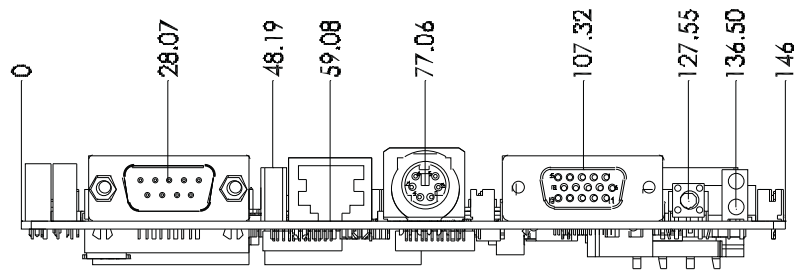

Figure 2.6 Board Dimension Layout (Coastline)

Chapter 3

BIOS Settings

3.1 Introduction

AMIBIOS has been integrated into many motherboards for over a decade. With the AMIBIOS Setup program, you can modify BIOS settings and control the various system features. This chapter describes the basic navigation of the PCM-9376 BIOS setup screens.



Figure 3.1 Setup Program Initial Screen

AMI's BIOS ROM has a built-in Setup program that allows users to modify the basic system configuration. This information is stored in battery-backed CMOS so it retains the Setup information when the power is turned off.

3.2 Entering Setup

Turn on the computer and check for the "patch" code. If there is a number assigned to the patch code, it means that the BIOS supports your CPU. If there is no number assigned to the patch code, please contact an Advantech application engineer to obtain an up-to-date patch code file. This will ensure that your CPU's system status is valid. After ensuring that you have a number assigned to the patch code, press and you will immediately be allowed to enter Setup.

3.3 Main Setup

When you first enter the BIOS Setup Utility, you will enter the Main setup screen. You can always return to the Main setup screen by selecting the Main tab. There are two Main Setup options. They are described in this section. The Main BIOS Setup screen is shown below.



The Main BIOS setup screen has two main frames. The left frame displays all the options that can be configured. Grayed-out options cannot be configured; options in blue can. The right frame displays the key legend.

Above the key legend is an area reserved for a text message. When an option is selected in the left frame, it is highlighted in white. Often a text message will accompany it.

3.3.1 System Time / System Date

Use this option to change the system time and date. Highlight System Time or System Date using the <Arrow> keys. Enter new values through the keyboard. Press the <Tab> key or the <Arrow> keys to move between fields. The date must be entered in MM/DD/YY format. The time must be entered in HH:MM:SS format.

3.4 Advanced BIOS Features Setup

Select the Advanced tab from the PCM-9376 setup screen to enter the Advanced BIOS Setup screen. You can select any of the items in the left frame of the screen, such as CPU Configuration, to go to the sub menu for that item. You can display an Advanced BIOS Setup option by highlighting it using the <Arrow> keys. All Advanced BIOS Setup options are described in this section. The Advanced BIOS Setup screens is shown below. The sub menus are described on the following pages.

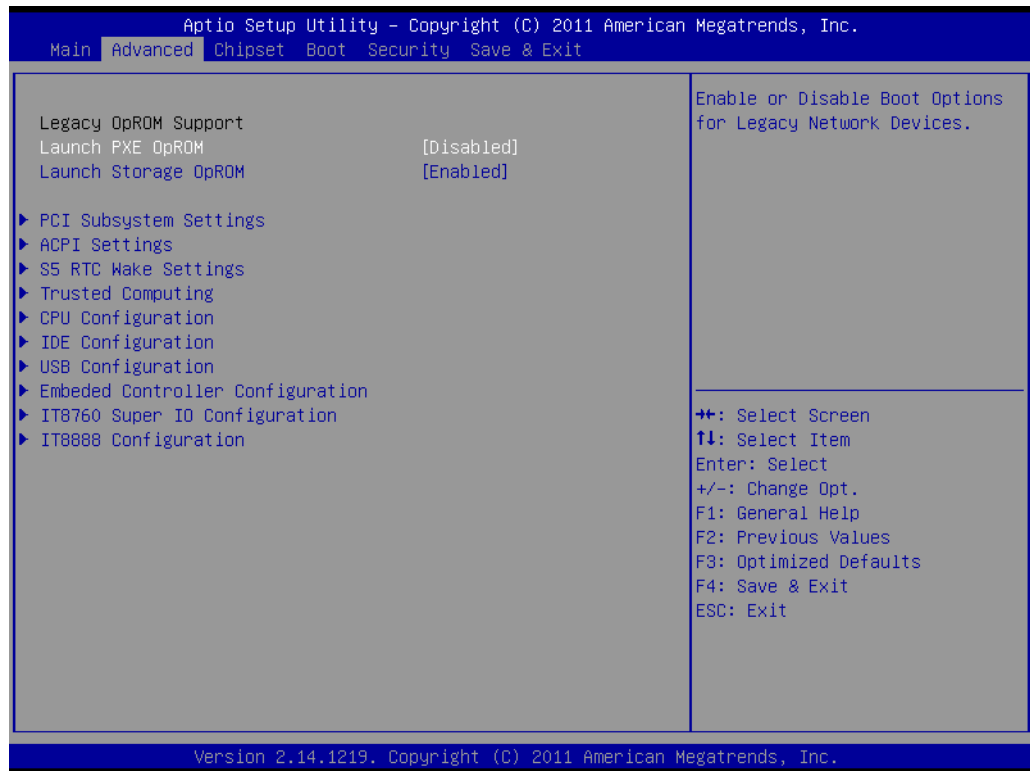

- **Launch PXE OpROM**
Enable or disable boot option for legacy network devices.
- **Launch Storage OpROM**
Enable or disable boot option for legacy mass storage with option ROM.

3.4.1 PCI Subsystem Settings Configuration

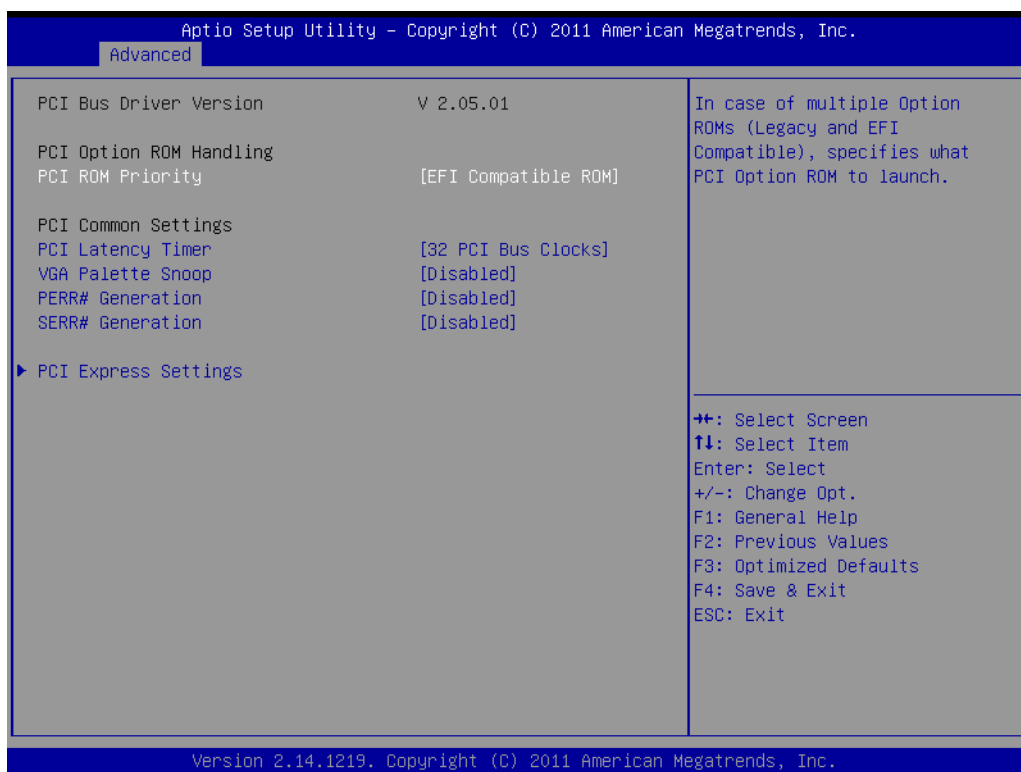

- **PCI ROM Priority**
This item allows you to select the EFI ROM and Legacy ROM priority.
- **PCI Latency Timer**
This item allows you to select the 32/64/96/128/160/192/224/248 PCI bus clocks.
- **VGA Palette Snoop**
Enabled or disable VGA palette registers snooping.
- **PERR# Generation**
Enabled or disable PCI device to generation PERR#.
- **SERR# Generation**
Enabled or disable PCI device to generation SERR#.
- **PCI Express Settings**
Change PCI express device detail settings.

3.4.2 ACPI Settings Configuration

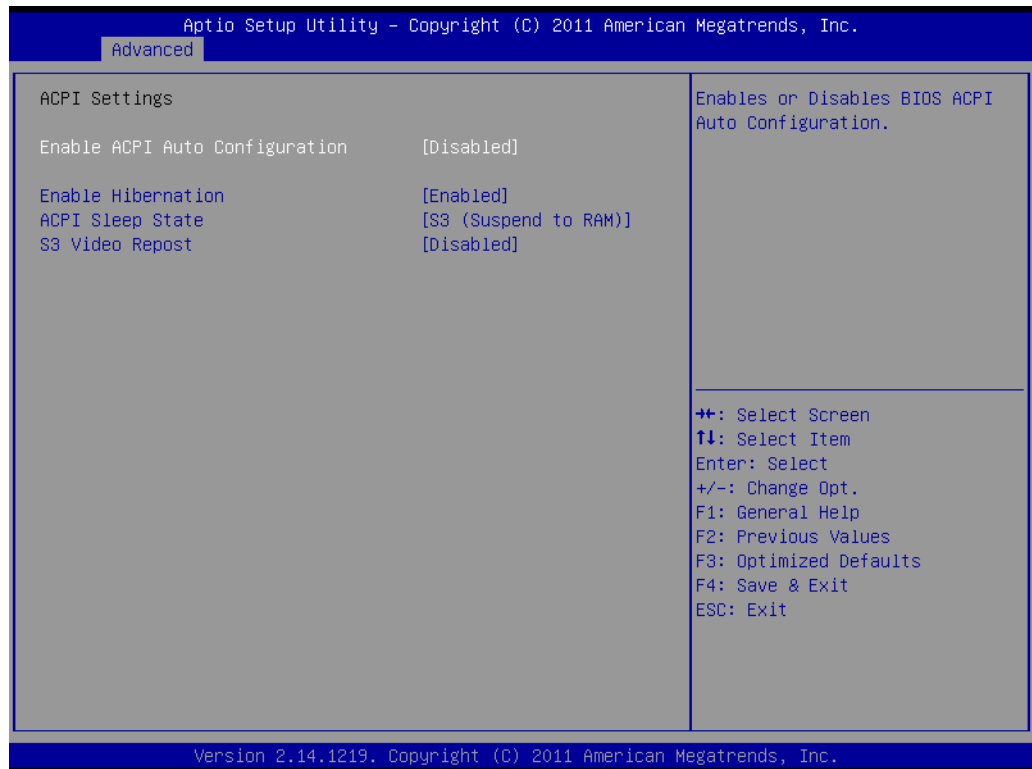

- **Enable ACPI Auto Configuration**
Enable or disable BIOS ACPI auto configuration.
- **Enable Hibernation**
Enable or disable hibernation function if OS support.
- **ACPI Sleep State**
Select the ACPI states used for system suspend.
- **S3 Video Repost**
Enable or disable video repost.

3.4.3 S5 RTC Wake Settings



- **Wake system with Fixed Time**
Enable or disable system wake on alarm event by user define.
- **Wake system with Dynamic Time**
Enable or disable system wake on alarm event from 1minutes to 5 minutes.

3.4.4 Trusted Computing



- **TPM support**
Enable or disable TPM support for security.

3.4.5 CPU Configuration

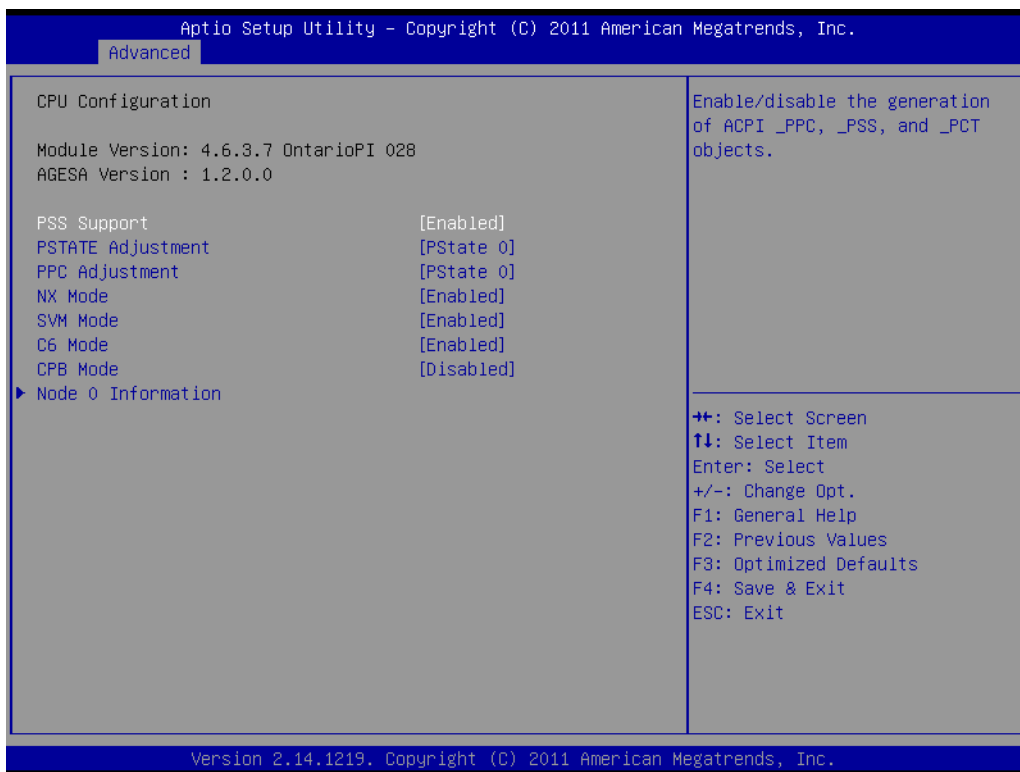

- **PPS Support**
This item allows you to enable or disable the ACPI _PPC, _PSS, and _PCT objects.
- **PSTATE Adjustment**
This item allows you to provide P-state level.
- **PPC Adjustment**
This item allows you to provide _PPC object.
- **NX Mode**
This item allows you to enable or disable the No-execute page protection function.
- **SVM Mode**
This item allows you to enable or disable the CPU virtualized.
- **C6 Mode**
This item allows you to auto or disable C6 function.
- **CPB Mode**
This item allows you to auto or disable CPB.
- **Node 0 Information**
View details of memory information related to node 0.

3.4.6 IDE Configuration

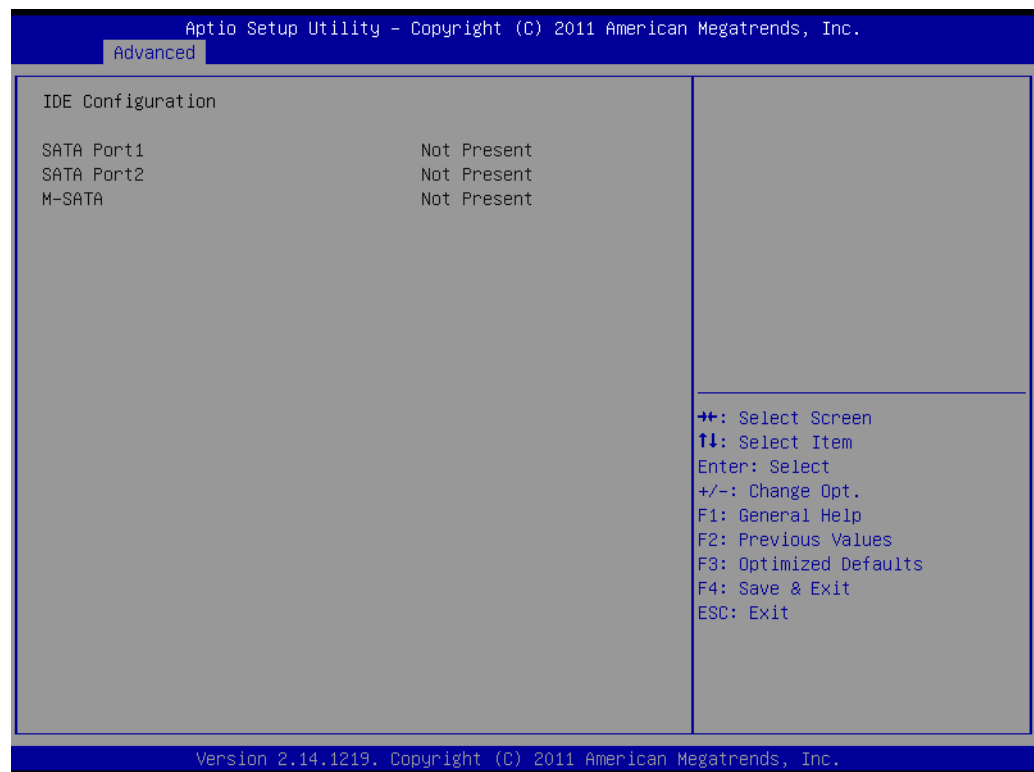

- **IDE Configuration**
Display SATA Port1 / SATA Port2 / M-SATA information.

3.4.7 USB Configuration

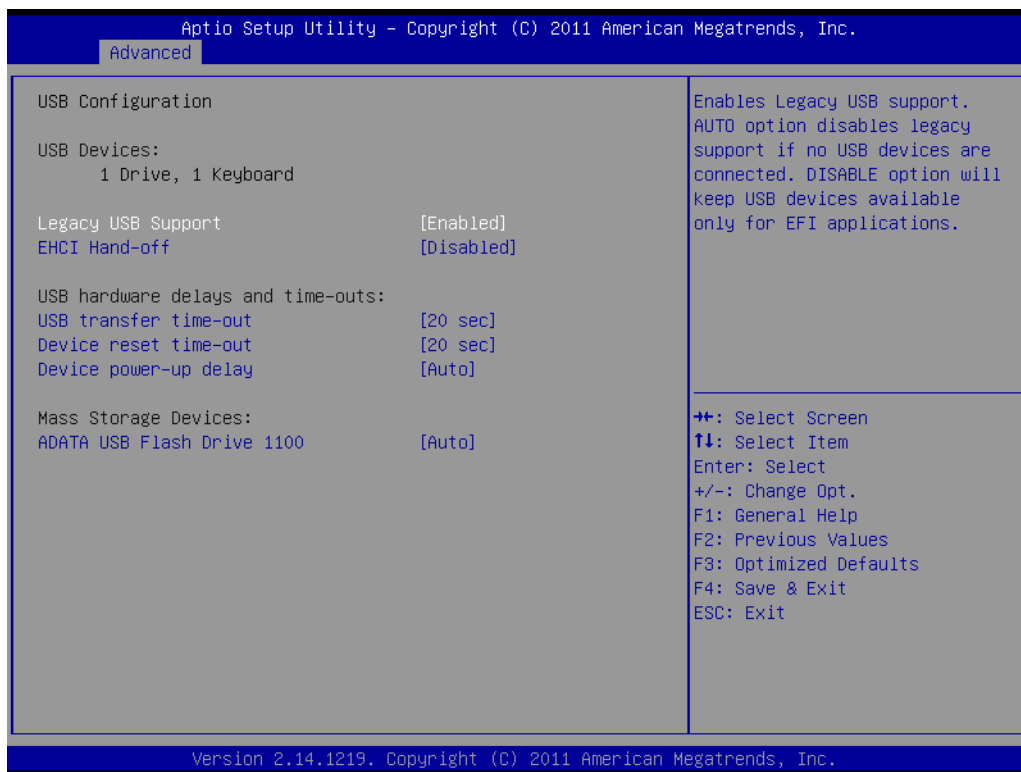

- **Legacy USB Support**
Enables support for legacy USB. Auto option disables legacy support if no USB devices are connected.
- **EHCI Hand-Off**
This is a workaround for OS without EHCI hand-off support. The EHCI ownership change should claim by EHCI driver.
- **USB transfer time-out**
Time-out value for control, Bulk, and interrupt transfers.
- **Device reset time-out**
USB mass storage device start unit command time-out.
- **Device power-up delay**
Maximum time the device will take before it properly report itself to the host controller.

3.4.8 Embedded Controller Configuration

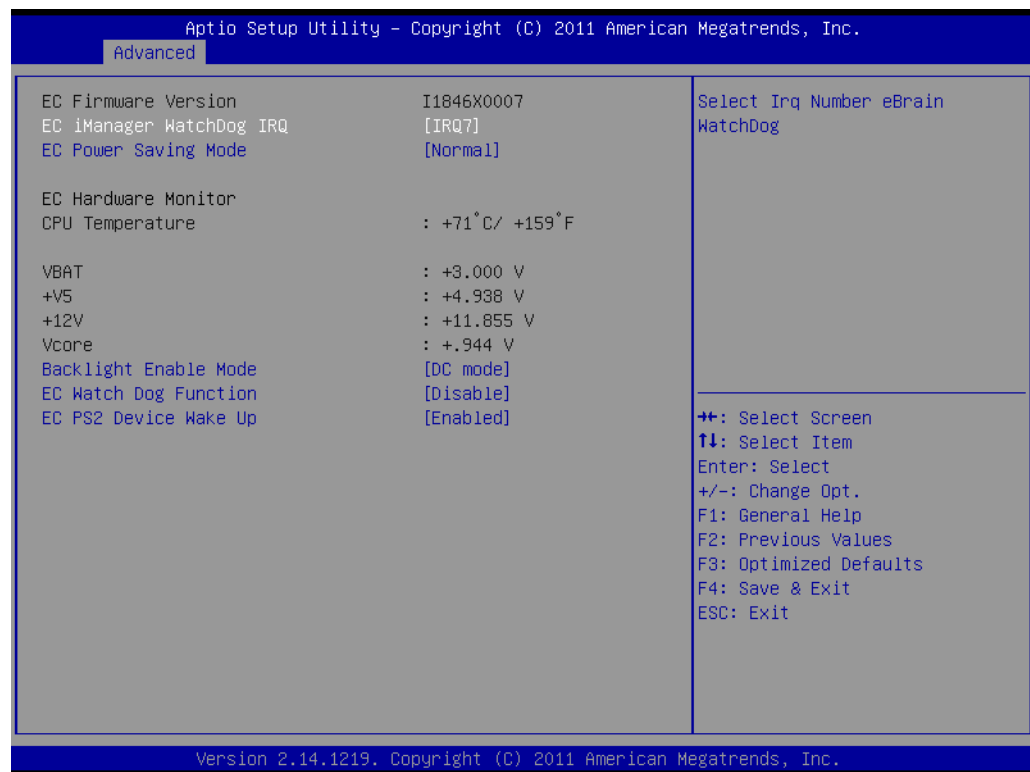

- **EC iManager WatchDog IRQ**
This item allows you to select EC of WDT IRQ.
- **EC Power Saving Mode**
This item allows you to select EC power saving mode.
- **EC Hardware Monitor**
Display board of CPU temp / voltage / battery information.
- **Backlight Enable Mode**
This item allows you to select backlight mode.
- **EC Watch Dog Function**
This item allows you to select EC of WDT timer.
- **EC PS2 Device Wake Up**
This item allows you to enable or disable EC of PS2 device wake up function.

3.4.9 Super I/O Configuration



- **Serial Port1 / Port2 / Port3 / Port4 address**
This item allows you to select serial port1 ~ port4 of base addresses.
- **Serial Port1 / Port2 / Port3 / Port4 IRQ**
This item allows you to select serial port1 ~ port4 of IRQ.

3.4.10 IT8888 Configuration

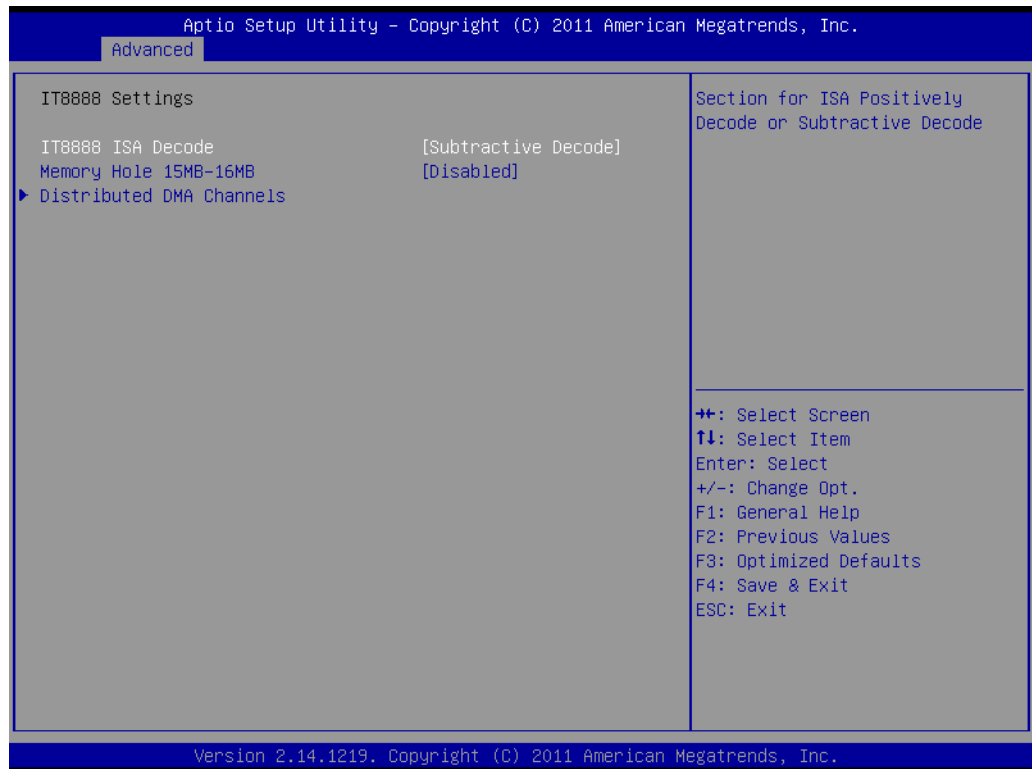

- **IT8888 ISA Decode**
This item allows you to select subtractive decode or positively decode.
- **Memory Hole 15MB-16MB**
This item allows you to enable or disable memory hole.
- **Distributed DMA Channels**
This item allows you to enable or disable DMA channels.

3.5 Chipset Configuration

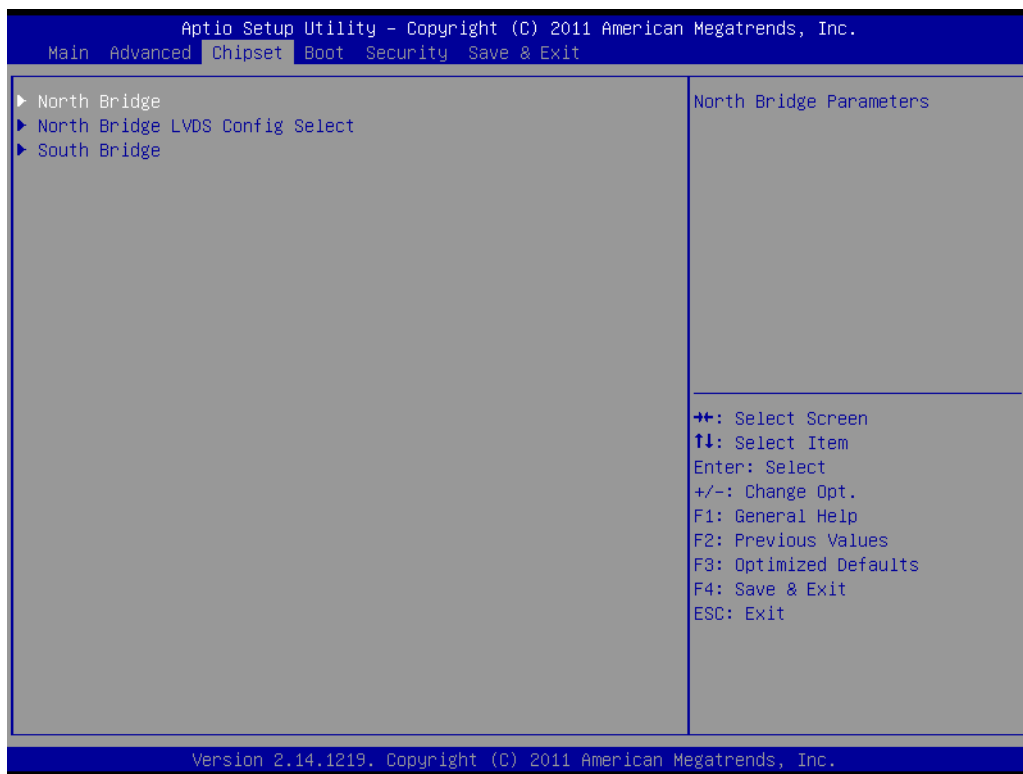

- **North Bridge**
Detail for North Bridge items.
- **North Bridge LVDS Config Select**
Detail for display items.
- **South Bridge**
Detail for South Bridge items.

3.5.1 North Bridge Configuration



- **GFX Configuration**
Detail of LAN1/LAN2/Mini PCIe, and PSPP Policy items.
- **Memory Configuration**
Detail of Integrated Graphics, Bank Interleaving items.

3.5.2 North Bridge LVDS Config Select

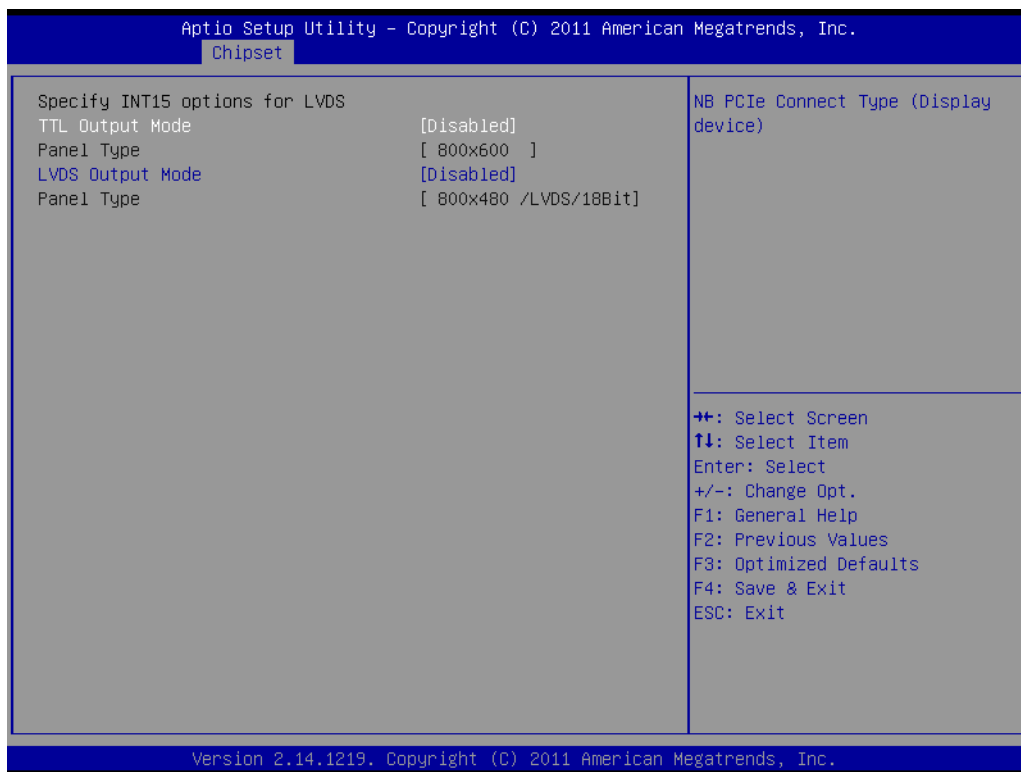

- **TTL Output Mode**
This item allows you to enable or disable TTL panel function.
- **LVDS Output Select**
This item allows you to select LVDS panel type of resolution.

3.5.3 South Bridge

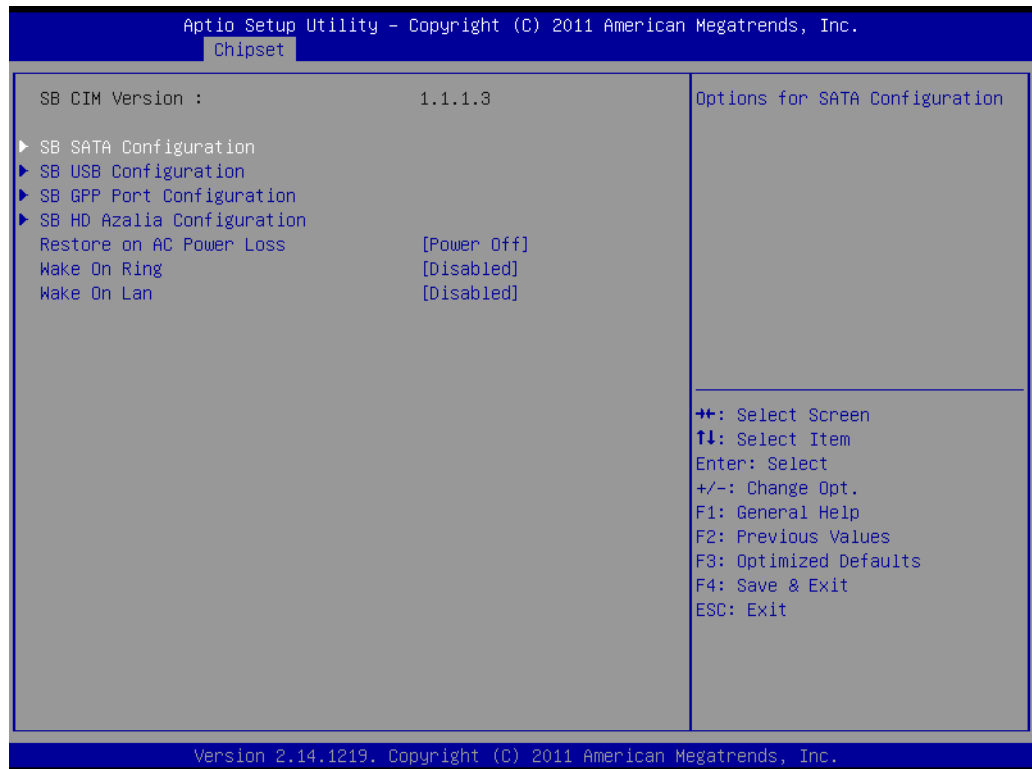

- **SB SATA Configuration**
Options for SATA configuration.
- **SB USB Configuration**
Options for SB USB configuration.
- **SB GPP Port Configuration**
Options for SB GPP port configuration.
- **SB HD Azalia Configuration**
Options for SB HD Azalia.
- **Restore on AC Power Loss**
This item allows you to select system restore states if AC power loss.
- **Wake On Ring / Wake On Lan**
This item allows you to enable or disable wake on LAN or Ring function.

3.6 Boot Settings



- **Setup Prompt Timeout**
This item allows you to change number of seconds to wait for setup activation key.
- **Bootup NumLock State**
Select the Power-on state for Numlock.
- **Quiet Boot**
If this option is set to Disabled, the BIOS displays normal POST messages. If Enabled, an OEM Logo is shown instead of POST messages.
- **GateA20 Active**
This item allows you to select Upon request or Always.
- **Option ROM Messages**
Set display mode for option ROM.
- **Interrupt 19 Capture**
This item allows option ROMs to trap interrupt 19.
- **CSM Support**
This item allows you to enable or disable CSM support.
- **Boot Option**
Sets the system boot order.

3.7 Security Configuration

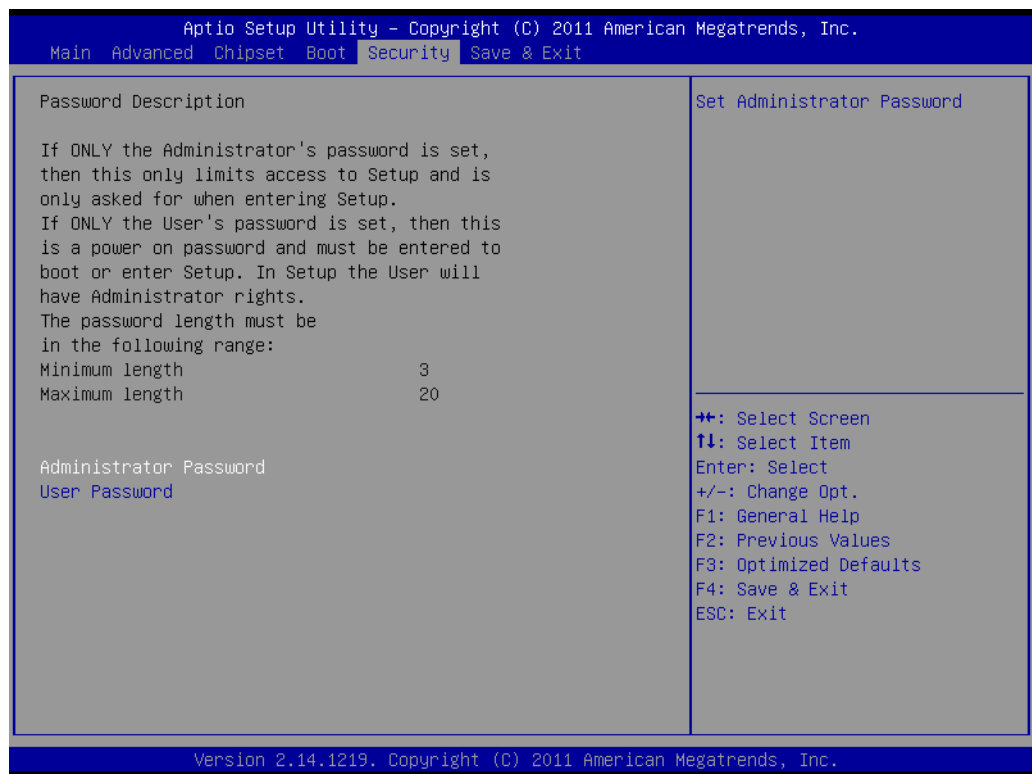

Select Security Setup from the PCM-9376 Setup main BIOS setup menu. All Security Setup options, such as password protection and virus protection are described in this section. To access the sub menu for the following items, select the item and press <Enter>:

- **Change Supervisor / User Password**

3.8 Save & Exit

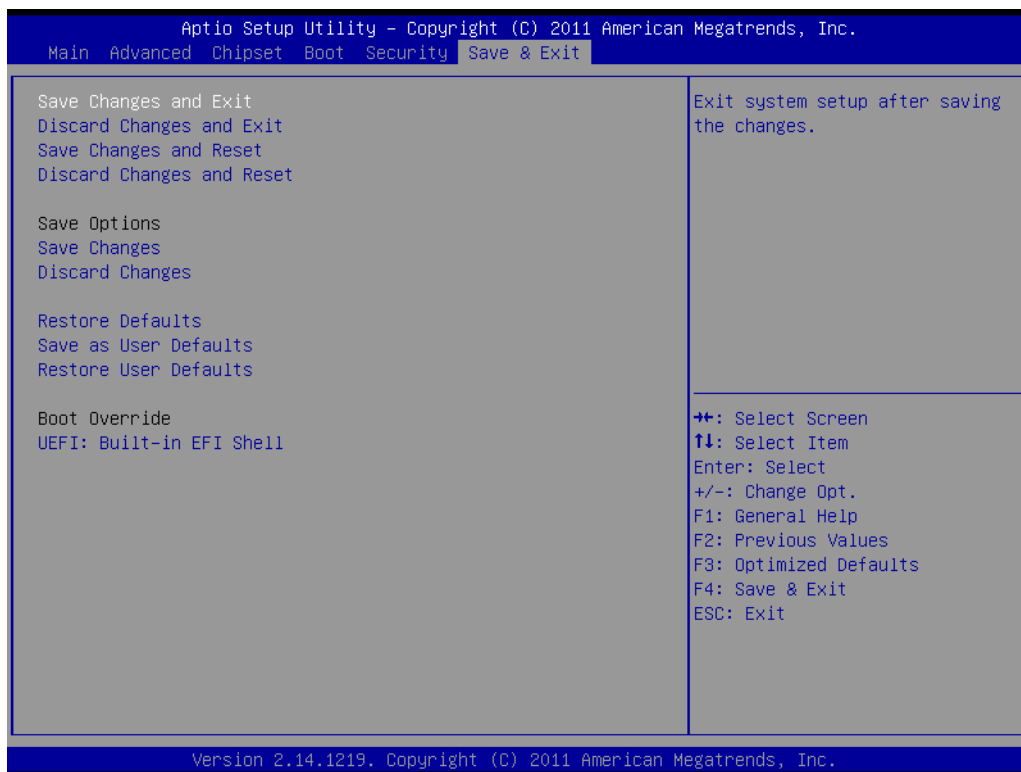

- **Save Changes and Exit**
This item allows you to exit system setup after saving the changes.
- **Discard Changes and Exit**
This item allows you to exit system setup without saving any changes.
- **Save Changes and Reset**
This item allows you to reset the system after saving the changes.
- **Discard Changes and Reset**
This item allows you to rest system setup without saving any changes.
- **Save Changes**
This item allows you to save changes done so far to any of the options.
- **Discard Changes**
This item allows you to discard changes done so far to any of the options.
- **Restore Defaults**
This item allows you to restore/load default values for all the options.
- **Save as User Defaults**
This item allows you to save the changes done so far as user defaults.
- **Restore User Defaults**
This item allows you to restore the user defaults to all the options.
- **Boot Override**
Boot device select can override your boot priority.

Appendix **A**

Pin Assignments

A.1 Jumper Setting

Table A.1: Jumper List

Location	Function
J1	AT/ATX power supply
J2	LCD power
J3	Clear CMOS

A.2 Connectors

Table A.2: Connector List

Location	Function
CN2	PC/104 -5/-12V power input
CN5	SATA
CN6	2 x Internal USB
CN7	2 x Internal USB
CN8	Internal COM3/4: RS-232
CN9	Internal COM2: RS-232/422/485
CN10	GPIO
CN11	Audio
CN12	Power input
CN13	SATA
CN14	ATX standby power input
CN15	SMBus / I ² C
CN16	PC/104
CN17	TTL
CN18	Inverter power
CN19	SATA power (5V/12V)
CN20	SATA power (5V)
CN21	Internal GbE
CN22	LVDS
CN23	External GbE
CN24	PS/2
CN25	Power Switch
CN26	External COM1: RS-232/422/485
CN27	VGA
CN28	Half-size Mini-PCIe
CN29	LPC
CN30	Full-size mSATA
CN31	DDR3 SODIMM

J1	AT/ATX power function Setting
Part Number	1653002101
Footprint	HD_2x1P_79_D
Description	PIN HEADER 2*1P 180D(M)SQUARE 2.0mm DIP W/O Pb
Setting	Function
NC	ATX
(1-2)*	AT

J2	LCD Power
Part Number	1653003201
Footprint	HD_3x2P_79_D
Description	PIN HEADER 3x2P 2.0mm 180D(M) DIP 21N22050
Setting	Function
(1-3)*	+3.3V
(3-5)	+5V
(3-4)	+12V

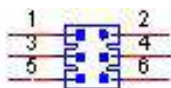

J3	Clear CMOS
Part Number	1653003101
Footprint	HD_3x1P_79_D
Description	PIN HEADER 3x1P 2.0mm 180D(M) DIP 2000-13 WS
Setting	Function
(1-2)*	Normal
(2-3)	Clear COMS

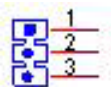

CN2	ISA -5V & -12V Input
Part Number	1653003101
Footprint	HD_3x1P_79_D
Description	PIN HEADER 3x1P 2.0mm 180D(M) DIP 2000-13 WS
Pin	Pin Name
1	-5V
2	GND
3	-12V

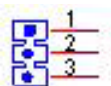

CN5	SATA
Part Number	1654004659
Footprint	SATA_7P_WATM-07DBN4A3B8UW_D
Description	Serial ATA 7P 1.27mm 180D(M) DIP WATM-07DBN4A3B8
Pin	Pin Name
1	GND
2	TX+
3	TX-
4	GND
5	RX-
6	RX+
7	GND

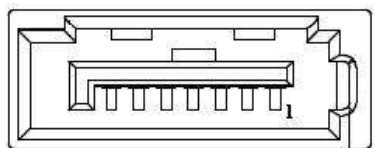

CN6	Internal USB
Part Number	1653005260
Footprint	HD_5x2P_79_N10
Description	PIN HEADER 2x5P 2.0mm 180D(M) SMD 21N22050
Pin	Pin Name
1	+5V
2	+5V
3	A_D-
4	B_D-
5	A_D+
6	B_D+
7	GND
8	GND
9	GND

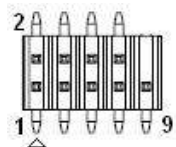

CN7	Internal USB
Part Number	1653005260
Footprint	HD_5x2P_79_N10
Description	PIN HEADER 2x5P 2.0mm 180D(M) SMD 21N22050
Pin	Pin Name
1	+5V

2	+5V
3	A_D-
4	B_D-
5	A_D+
6	B_D+
7	GND
8	GND
9	GND

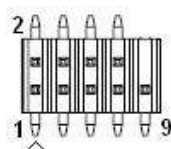

CN8	COM3/COM4
Part Number	1653004793
Footprint	HD_10x2P_79_23N685B-20M10
Description	BOX HEADER 10x2P 2.0mm 180D(M)SMD 23N685B-20M10B
Pin	Pin Name
1	DCD3#
2	DSR3#
3	RXD3
4	RTS3#
5	TXD3
6	CTS3#
7	DTR3#
8	RI3#
9	GND
10	GND
11	DCD4#
12	DSR4#
13	RXD4
14	RTS4#
15	TXD4
16	CTS4#
17	DTR4#
18	RI4#
19	GND
20	GND

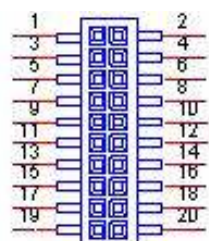

CN9	COM2
Part Number	1653004099
Footprint	HD_5x2P_79_23N685B-10M10
Description	BOX HEADER 5x2P 2.00mm 180D(M) SMD 23N685B-10M10
Pin	Pin Name
1	DCD1#
2	DSR1#
3	RXD1
4	RTS1#
5	TXD1
6	CTS1#
7	DTR1#
8	RI1#
9	GND
10	GND

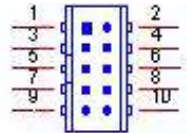

CN10	GPIO
Part Number	1653005201
Footprint	HD_5x2P_79_D
Description	PIN HEADER 5*2P 180D(M) SQUARE 2.0mm
Pin	Pin Name
1	+5V
2	GPIO4
3	GPIO0
4	GPIO5
5	GPIO1
6	GPIO6
7	GPIO2
8	GPIO7
9	GPIO3
10	GND

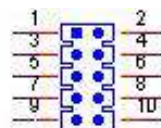

CN11	Audio
Part Number	1653004099
Footprint	HD_5x2P_79_23N685B-10M10
Description	BOX HEADER 5x2P 2.00mm 180D(M) SMD 23N685B-10M10
Pin	Pin Name
1	LOUTR
2	LINR
3	GND
4	GND
5	LOUTL
6	LINL
7	GND
8	GND
9	MIC1R
10	MIC1L

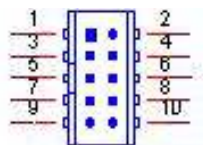

CN12	AT Power Input
Part Number	1655204030
Footprint	WF_4P_200_R1_D
Description	WAFER 4P 5.08mm 180D(M) DIP 626M-04
Pin	Pin Name
1	+12V
2	GND
3	GND
4	+5V

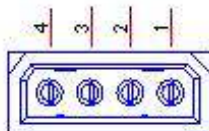

CN13	SATA
Part Number	1654004659
Footprint	SATA_7P_WATM-07DBN4A3B8UW_D
Description	Serial ATA 7P 1.27mm 180D(M) DIP WATM-07DBN4A3B8
Pin	Pin Name
1	GND
2	TX+
3	TX-
4	GND

5	RX-
6	RX+
7	GND

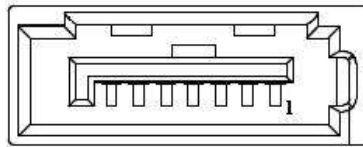

CN14	Standby Power Input
Part Number	1655303020
Footprint	WHL3V-2M
Description	WAFER BOX 3P 2.0mm 180D(M) DIP 2001-WS-3
Pin	Pin Name
1	+5VSB
2	GND
3	PSON#



CN15	SMBus
Part Number	1655304020
Footprint	WF_4P_79_BOX_R1_D
Description	WAFER BOX 2.0mm 4P 180D(M) W/LOCK A2001WV2-4P
Pin	Pin Name
1	GND
2	SMB_DAT
3	SMB_CLK
4	+5V

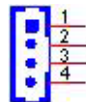

CN16	PC/104
Part Number	165312022A 165313222A
Footprint	PC104
Description	PCB SKT 20x2P 2.54mm 180D(F) DIP 962-40202-03 PCB SKT 32x2P 2.54mm 180D(F) DIP 962-40322-03
Pin	Pin Name
A1	IOCHCK
A2	SD7
A3	SD6

A4	SD5
A5	SD4
A6	SD3
A7	SD2
A8	SD1
A9	SD0
A10	IOCHRDY
A11	AEN
A12	SA19
A13	SA18
A14	SA17
A15	SA16
A16	SA15
A17	SA14
A18	SA13
A19	SA12
A20	SA11
A21	SA10
A22	SA9
A23	SA8
A24	SA7
A25	SA6
A26	SA5
A27	SA4
A28	SA3
A29	SA2
A30	SA1
A31	SA0
A32	GND
B1	GND
B2	RSTDRV
B3	+5V
B4	IRQ9
B5	-5V
B6	DRQ2
B7	-12V
B8	0WS#
B9	+12V
B10	GND
B11	SMEMW#
B12	SMEMR#
B13	IOW#
B14	IOR#
B15	DACK3#
B16	DRQ3
B17	DACK1#
B18	DRQ1
B19	REFRESH#

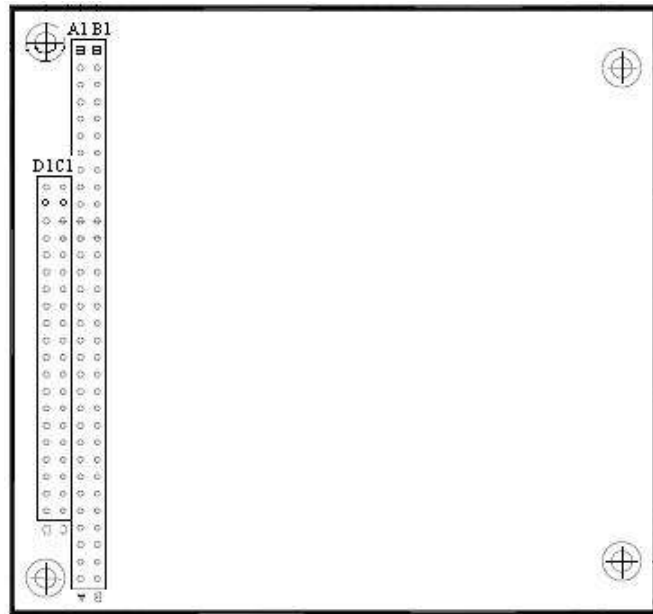

CN17	TTL Panel
Part Number	1653920200
Footprint	SPH20X2
Description	B/B Conn. 40P 1.25mm 90D SMD DF13-40DP-1.25V(91)
Pin	Pin Name
1	+5V
2	+5V
3	GND
4	GND
5	+3.3V
6	+3.3V
7	NC
8	GND
9	PD0
10	PD1
11	PD2
12	PD3
13	PD4
14	PD5
15	PD6
16	PD7
17	PD8
18	PD9
19	PD10
20	PD11
21	PD12
22	PD13
23	PD14
24	PD15

25	PD16
26	PD17
27	PD18
28	PD19
29	PD20
30	PD21
31	PD22
32	PD23
33	GND
34	GND
35	SHFCLK
36	FLM (V-SYNC)
37	M/DE
38	LP (H-SYNC)
39	NC
40	ENVEE



CN18	Inverter Power Output
Part Number	1655000453
Footprint	WHL5V-2M-24W1140
Description	WAFER BOX 2.0mm 5P 180D(M) DIP WO/Pb JIH VEI
Pin	Pin Name
1	+12V
2	GND
3	ENABKL
4	VBR
5	+5V

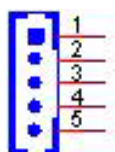

CN19	SATA Power
Part Number	1655001154
Footprint	WF_4P_98_BOX_R1_D
Description	WAFER BOX 4P 2.50mm 180D(M) DIP 24W1170-04S10-01
Pin	Pin Name
1	+5V
2	GND
3	GND
4	+12V

CN20	SATA Power
Part Number	1655302020
Footprint	WF_2P_79_BOX_R1_D
Description	WAFER BOX 2P 2.0mm 180D(M) DIP A2001WV2-2P
Pin	Pin Name
1	+5V
2	GND

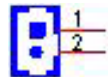

CN21	LAN2
Part Number	1653004099
Footprint	HD_5x2P_79_23N685B-10M10
Description	BOX HEADER 5x2P 2.00mm 180D(M) SMD 23N685B-10M10
Pin	Pin Name
1	GND
2	GND
3	BI_DD+(GHz)
4	BI_DD-(GHz)
5	BI_DC+(GHz)
6	BI_DC-(GHz)
7	RX+(10/100),BI_DB+(GHz)
8	RX-(10/100),BI_DB-(GHz)
9	TX+(10/100),BI_DA+(GHz)
10	TX-(10/100),BI_DA-(GHz)

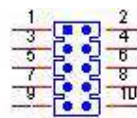

CN22	48 bits LVDS Panel
Part Number	1653920200
Footprint	SPH20X2
Description	B/B Conn. 40P 1.25mm 90D SMD DF13-40DP-1.25V(91)
Pin	Pin Name
1	+5V or +3.3V or +12V
2	+5V or +3.3V or +12V
3	GND
4	GND
5	+5V or +3.3V or +12V
6	+5V or +3.3V or +12V
7	LVDS0_D0-
8	LVDS1_D0-
9	LVDS0_D0+
10	LVDS1_D0+
11	GND
12	GND
13	LVDS0_D1-
14	LVDS1_D1-
15	LVDS0_D1+
16	LVDS1_D1+
17	GND
18	GND
19	LVDS0_D2-
20	LVDS1_D2-
21	LVDS0_D2+
22	LVDS1_D2+
23	GND
24	GND
25	LVDS0_CLK-
26	LVDS1_CLK-
27	LVDS0_CLK+
28	LVDS1_CLK+
29	GND
30	GND
31	NC
32	NC
33	GND
34	GND
35	LVDS0_D3-
36	LVDS1_D3-
37	LVDS0_D3+
38	LVDS1_D3+
39	NC
40	NC



CN23	LAN2
Part Number	1652508203
Footprint	RJ45-RJM5
Description	PHONE JACK RJ45 8P8C 90D SHIELDED 9743-10811-SE
Pin	Pin Name
1	BI_DA+(GHz)
2	BI_DA-(GHz)
3	BI_DB+(GHz)
4	BI_DC+(GHz)
5	BI_DC-(GHz)
6	BI_DB-(GHz)
7	BI_DD+(GHz)
8	BI_DD-(GHz)

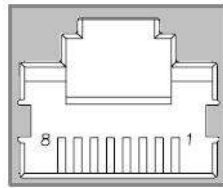

CN24	PS2
Part Number	1654003199
Footprint	CONTEK_MQN3261F1G400
Description	MINI DIN 6P 90D(F) DIP MQN3261F1G400
Pin	Pin Name
1	KBDAT
2	MSDAT
3	GND
4	+5V
5	KBCLK
6	MSCLK

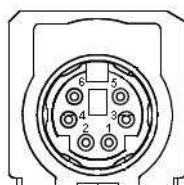

CN25	Power Switch
Part Number	1655302020
Footprint	WF_2P_79_BOX_R1_D
Description	WAFER BOX 2P 2.0mm 180D(M) DIP A2001WV2-2P
Pin	Pin Name
1	PSIN
2	GND

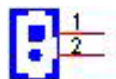

CN26	COM1
Part Number	1654409108
Footprint	SUYIN_070205MR009S202BA
Description	D-SUB Conn. 9P 5mm 90D(M) 070205MR009S202BA
Pin	Pin Name
1	DCD#
2	RXD
3	TXD
4	DTR#
5	GND
6	DSR#
7	RTS#
8	CTS#
9	RI#

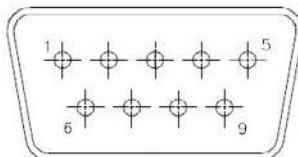

CN27	VGA
Part Number	1654009560
Footprint	DSUB_15P_1760015-046-R
Description	
Pin	Pin Name
1	RED
2	GREEN

3	BLUE
4	NC
5	GND
6	GND
7	GND
8	GND
9	NC
10	GND
11	NC
12	DDAT
13	HSYNC
14	VSYNC
15	DCLK

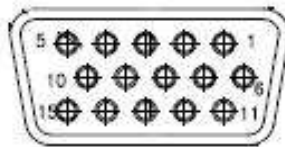

CN28	Mini PCIE
Part Number	1654002538
Footprint	MINIPCIE_HALF_PCM-9376
Description	
Pin	Pin Name
1	WAKE#
2	+3.3VSB
3	NC
4	GND
5	NC
6	+1.5V
7	NC
8	UIM_PWR
9	GND
10	UIM_DATA
11	REFCLK-
12	UIM_CLK
13	REFCLK+
14	UIM_RESET
15	GND
16	UIM_VPP
17	NC
18	GND
19	NC
20	W_DISABLE#
21	GND
22	PERST#
23	PERn0

24	+3.3VSB
25	PERp0
26	GND
27	GND
28	+1.5V
29	GND
30	SMB_CLK
31	PETn0
32	SMB_DAT
33	PETp0
34	GND
35	GND
36	USB D-
37	GND
38	USB D+
39	+3.3VSB
40	GND
41	+3.3VSB
42	NC
43	SEL
44	NC
45	NC
46	NC
47	NC
48	+1.5V
49	NC
50	GND
51	NC
52	+3.3VSB

CN29	LPC
Part Number	00A00000830
Footprint	LPC_BOARD_PCE-5026_SMD
Description	
Pin	Pin Name
1	CLK
2	AD1
3	RESET#
4	AD0
5	FRAME#
6	+3.3V
7	AD3
8	GND
9	AD2
10	NC
11	LPC_SERIRQ
12	PWROK

13	+5V
14	+5V

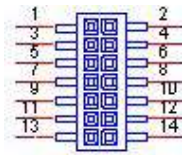

CN30	mSATA
Part Number	1654002538
Footprint	MINIPCIE_HALF_PICO_ITX
Description	
Pin	Pin Name
1	WAKE#
2	+3.3VSB
3	NC
4	GND
5	NC
6	+1.5V
7	NC
8	UIM_PWR
9	GND
10	UIM_DATA
11	REFCLK-
12	UIM_CLK
13	REFCLK+
14	UIM_RESET
15	GND
16	UIM_VPP
17	NC
18	GND
19	NC
20	W_DISABLE#
21	GND
22	PERST#
23	PERn0
24	+3.3VSB
25	PERp0
26	GND
27	GND
28	+1.5V
29	GND
30	SMB_CLK
31	PETn0
32	SMB_DAT
33	PETp0
34	GND

35	GND
36	USB D-
37	GND
38	USB D+
39	+3.3VSB
40	GND
41	+3.3VSB
42	NC
43	SEL
44	NC
45	NC
46	NC
47	NC
48	+1.5V
49	NC
50	GND
51	NC
52	+3.3VSB
<hr/>	
CN31	SODIMDDR3RVS_204
Part Number	1651002082
Footprint	DDR3_204P_AS0A626-N2

Appendix **B**

System Assignment

B.1 System I/O Ports

Table B.1: System I/O Ports

Addr. Range (Hex)	Device
000-02F	DMA Controller
020-02D	Interrupt Controller
040-04F	System resource
050-052	Timer/Counter
060-06F	8042 (keyboard controller)
070-07F	Real-time clock, non-maskable interrupt (NMI) mask
080-09F	DMA page register
0A0-0FF	System resource
0C0-0DF	DMA controller
0F0-0FF	System resource
170-177	IDE Controller
1F0-1F7	IDE Controller
290-29F	EC resource
2E8-2EF	Serial port 4
2F8-2FF	Serial port 2
3C0-3DF	System resource
3E8-3EF	Serial port 3
3F8-3FF	Serial port 1
400-4FF	System resource
800-8FF	System resource
B00-B3F	System resource
C00-CFF	System resource

B.2 1st MB Memory Map

Table B.2: 1st MB Memory Map

Addr. Range (Hex)	Device
F0000h - FFFFFh	System ROM
D0000h – E7FFFh	Unused (reserved for Ethernet ROM)
C0000h – CFFFFh	Expansion ROM (for VGA BIOS)
B8000h - BFFFFh	CGA/EGA/VGA text
A0000h - B7FFFh	EGA/VGA graphics
00000h - 9FFFFh	Base memory

B.3 Interrupt Assignments

Table B.3: Interrupt Assignments

Interrupt#	Interrupt source
IRQ0	Interval timer
IRQ1	Keyboard
IRQ2	Interrupt from controller 2 (cascade)
IRQ3	COM2
IRQ4	COM1
IRQ5	COM3
IRQ6	Available
IRQ7	Available
IRQ8	RTC
IRQ9	Reserved
IRQ10	Available
IRQ11	COM4
IRQ12	Reserved
IRQ13	Math Coprocessor
IRQ14	Primary IDE
IRQ15	Secondary IDE

Appendix **C**

Watchdog Timer Programming

C.1 EC Watchdog Timer Sample Code

```
EC_Command_Port = 0x29Ah
EC_Data_Port = 0x299h
Write EC HW ram = 0x89
Watchdog event flag = 0x57
Watchdog reset delay time = 0x5E (high byte), 0x5F (low byte)
Reset event = 0x04
Start WDT function = 0x28
Stop WDT function = 0x29
Reset WDT function = 0x2A
=====
.model small
.486p
.stack 256
.data
.code
org 100h
.STARTup

mov dx, EC_Command_Port
mov al,89h           ; Write EC HW ram.
out dx,al

mov dx, EC_Data_Port
mov al, 5Fh         ; Watchdog reset delay time low byte (5Eh
is high byte) index, Timebase: 100ms
out dx,al

mov dx, EC_Data_Port
mov al, 30h         ;Set 3 seconds delay time.
out dx,al

mov dx, EC_Command_Port
mov al,89h           ; Write EC HW ram.
out dx,al

mov dx, EC_Data_Port
mov al, 57h         ; Watchdog event flag.
out dx,al

mov dx, EC_Data_Port
mov al, 04h         ; Reset event.
out dx,al

mov dx, EC_Command_Port
```



```
mov al,28h           ; start WDT function.  
out dx,al  
  
.exit  
END
```

ADVANTECH

Enabling an Intelligent Planet

www.advantech.com

Please verify specifications before quoting. This guide is intended for reference purpOS only.

All product specifications are subject to change without notice.

No part of this publication may be reproduced in any form or by any means, electronic, photocopying, recording or otherwise, without prior written permission of the publisher.

All brand and product names are trademarks or registered trademarks of their respective companies.

© Advantech Co., Ltd. 2014