

REV.	DATE	ECR NO.	DESCRIPTION
NC	04/13/09	XXXXXX	INITIAL RELEASE

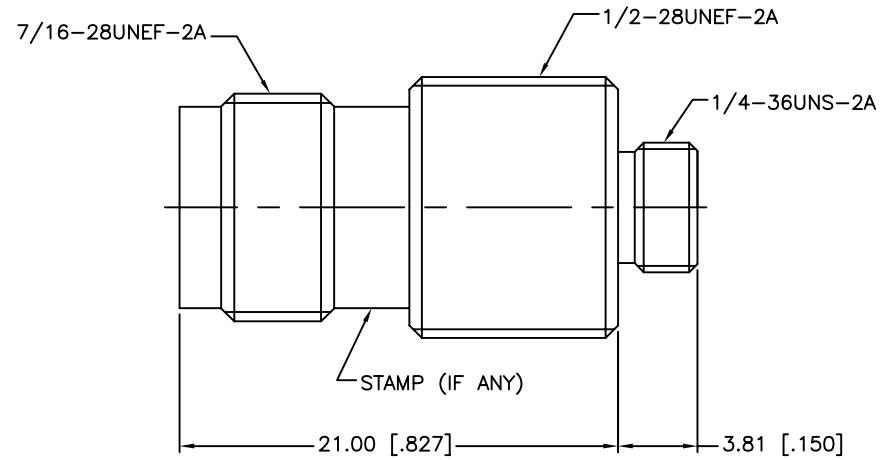
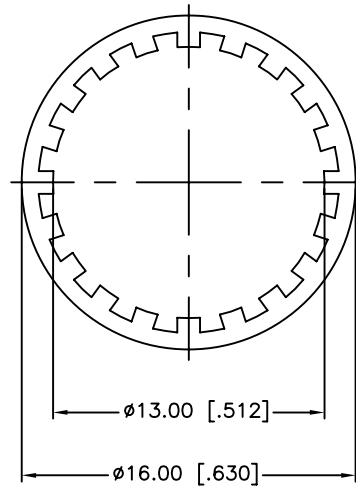
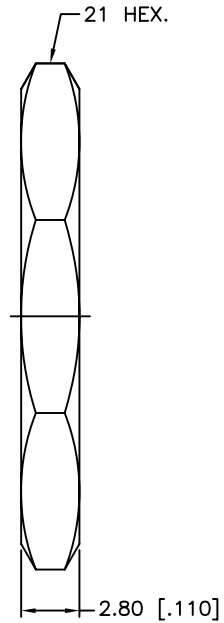

1. MAX. PANEL THICKNESS=6mm

7	HEX NUT	BRASS	NICKEL	1
6	LOCK WASHER	BRASS	NICKEL	1
5	LOCK RING	BRASS	NICKEL	1
4	CONTACT PIN	BER. COPPER	GOLD	1
3	INSULATOR	PTFE	NATURAL	1
2	INSULATOR	PTFE	NATURAL	1
1	BODY	BRASS	NICKEL	1
DESCRIPTION	MATERIAL	FINISH	QTY	

UNLESS OTHERWISE SPECIFIED DIMENSIONS ARE IN MILLIMETERS. DIMENSIONS IN [] ARE IN INCHES AND FOR CUSTOMER REFERENCE ONLY.

UNLESS OTHERWISE SPECIFIED TOLERANCES FOR MILLIMETERS ARE:
0.5 - 8mm \pm 0.20mm
8 - 30mm \pm 0.40mm
30 - 120mm \pm 0.50mm

UNLESS OTHERWISE SPECIFIED TOLERANCES FOR INCHES ARE:
.020 - .315 = \pm 0.007"
.315 - 1.180 = \pm 0.015"
1.180 - 4.724 = \pm 0.020"

DO NOT SCALE DRAWING

APPROVALS	DATE
DRAWN M.ZHANG	04/13/09
CHECKED	
ISSUED	
SHEET 1 OF 1	
CAD FILE C:/CONNEX/242211.DWG	

Amphenol Connex			
PART DESCRIPTION TNC BULKHEAD JACK TO MCX JACK ADAPTOR			
PART NO. 242211			
DWG. NO.	242211.DWG	REV. NC	SIZE A SCALE NA