

# AT-42000

## Up to 6 GHz Medium Power Silicon Bipolar Transistor Chip



### Data Sheet

#### Description

Avago's AT-42000 is a general purpose NPN bipolar transistor chip that offers excellent high frequency performance. The 4 micron emitter-to-emitter pitch enables this transistor to be used in many different functions. The 20 emitter finger interdigitated geometry yields a medium sized transistor with impedances that are easy to match for low noise and medium power applications.

This device is designed for use in low noise, wideband amplifier, mixer and oscillator applications in the VHF, UHF, and microwave frequencies. An optimum noise match near  $50\Omega$  up to 1 GHz, makes this device easy to use as a low noise amplifier.

The AT-42000 bipolar transistor is fabricated using Avago's 10 GHz ft Self-Aligned-Transistor (SAT) process. The die is nitride passivated for surface protection. Excellent device uniformity, performance and reliability are produced by the use of ionimplantation, self-alignment techniques, and gold metalization in the fabrication of this device.

The recommended assembly procedure is gold-eutectic die attach at 400°C and either wedge or ball bonding using 0.7 mil gold wire. See APPLICATIONS section, "Chip Use".

#### Features

- High Output Power:  
21.0 dBm Typical P1 dB at 2.0 GHz  
20.5 dBm Typical P1 dB at 4.0 GHz
- High Gain at 1 dB  
Compression:  
15.0 dB Typical G1 dB at 2.0 GHz  
10.0 dB Typical G1 dB at 4.0 GHz
- Low Noise Figure: 1.9 dB  
Typical NFO at 2.0 GHz
- High Gain-Bandwidth  
Product: 9.0 GHz Typical ft

#### Chip Outline

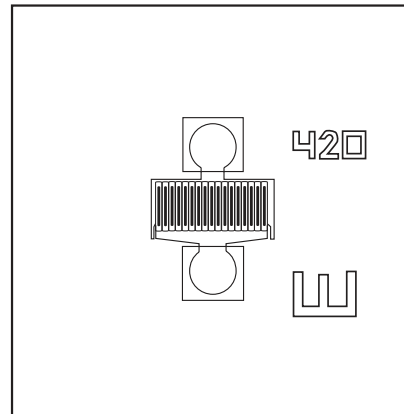

**CAUTION:** It is advised that normal static precautions be taken in handling and assembly of this component to prevent damage and/or degradation which may be induced by ESD.

## AT-42000 Absolute Maximum Ratings

| Symbol           | Parameter                          | Units | Absolute Maximum <sup>[1]</sup> |
|------------------|------------------------------------|-------|---------------------------------|
| V <sub>EBO</sub> | Emitter-Base Voltage               | V     | 1.5                             |
| V <sub>CB0</sub> | Collector-Base Voltage             | V     | 20                              |
| V <sub>CEO</sub> | Collector-Emitter Voltage          | V     | 12                              |
| I <sub>C</sub>   | Collector Current                  | mA    | 80                              |
| P <sub>T</sub>   | Power Dissipation <sup>[2,3]</sup> | mW    | 600                             |
| T <sub>j</sub>   | Junction Temperature               | °C    | 200                             |
| T <sub>STG</sub> | Storage Temperature                | °C    | -65 to 200                      |

Thermal Resistance<sup>e[2,4]</sup>:  
 $\theta_{jc} = 70^{\circ}\text{C/W}$

### Notes:

1. Permanent damage may occur if any of these limits are exceeded.
2. T<sub>Mounting Surface</sub> = 25°C.
3. Derate at 14.3 mW/°C for T<sub>Mounting Surface</sub> > 158°C.
4. The small spot size of this technique results in a higher, though more accurate determination of  $\theta_{jc}$  than do alternate methods. See MEASUREMENTS section "Thermal Resistance" for more information.

## Part Number Ordering Information

| Part Number  | Devices Per Tray |
|--------------|------------------|
| AT-42000-GP4 | 100              |

## Electrical Specifications, T<sub>A</sub> = 25 °C

| Symbol                          | Parameters and Test Conditions <sup>[1]</sup>   | Units                      | Min. | Typ.         | Max. |
|---------------------------------|---|----------------------------|------|--------------|------|
| S <sub>21E</sub>   <sup>2</sup> | Insertion Power Gain; V <sub>CE</sub> = 8 V, I <sub>C</sub> = 35 mA                   | f = 2.0 GHz<br>f = 4.0 GHz |      | 11.5<br>5.5  |      |
| P <sub>1 dB</sub>               | Power Output @ 1 dB Gain Compression<br>V <sub>CE</sub> = 8 V, I <sub>C</sub> = 35 mA | f = 2.0 GHz<br>f = 4.0 GHz |      | 21.0<br>20.5 |      |
| G <sub>1 dB</sub>               | 1 dB Compressed Gain; V <sub>CE</sub> = 8 V, I <sub>C</sub> = 35 mA                   | f = 2.0 GHz<br>f = 4.0 GHz |      | 15.0<br>10.0 |      |
| NF <sub>O</sub>                 | Optimum Noise Figure: V <sub>CE</sub> = 8 V, I <sub>C</sub> = 10 mA                   | f = 2.0 GHz<br>f = 4.0 GHz |      | 1.9<br>3.0   |      |
| G <sub>A</sub>                  | Gain @ NF <sub>O</sub> ; V <sub>CE</sub> = 8 V, I <sub>C</sub> = 10 mA                | f = 2.0 GHz<br>f = 4.0 GHz |      | 14.0<br>10.5 |      |
| f <sub>T</sub>                  | Gain Bandwidth Product: V <sub>CE</sub> = 8 V, I <sub>C</sub> = 35 mA                 |                            |      | 9.0          |      |
| h <sub>FE</sub>                 | Forward Current Transfer Ratio; V <sub>CE</sub> = 8 V, I <sub>C</sub> = 35 mA         |                            | 30   | 150          | 270  |
| I <sub>CB0</sub>                | Collector Cutoff Current; V <sub>CB</sub> = 8 V                                       |                            |      |              | 0.2  |
| I <sub>EBO</sub>                | Emitter Cutoff Current; V <sub>EB</sub> = 1 V   |                            |      |              | 2.0  |
| C <sub>CB</sub>                 | Collector Base Capacitance <sup>[2]</sup> : V <sub>CB</sub> = 8 V, f = 1 MHz          |                            |      | 0.23         |      |

### Notes:

1. RF performance is determined by packaging and testing 10 devices per wafer.
2. For this test, the emitter is grounded.

**AT-42000 Typical Performance,  $T_A = 25\text{ }^\circ\text{C}$**

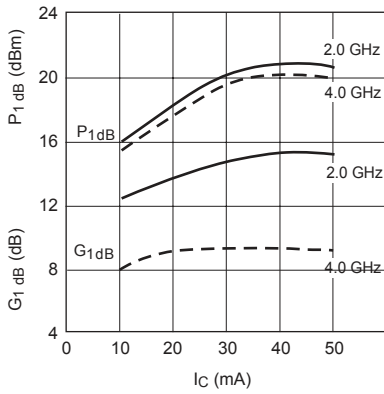

**Figure 1. Output Power and 1 dB Compressed Gain vs. Collector Current and Frequency.  $V_{CE} = 8\text{ V}$ .**

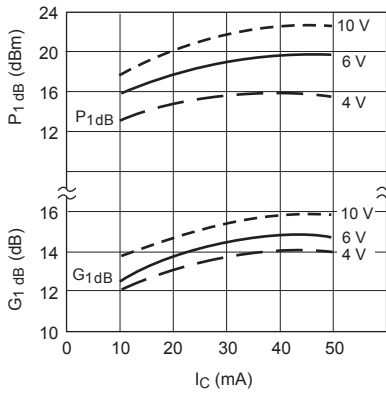

**Figure 2. Output Power and 1 dB Compressed Gain vs. Collector Current and Voltage.  $f = 2.0\text{ GHz}$ .**

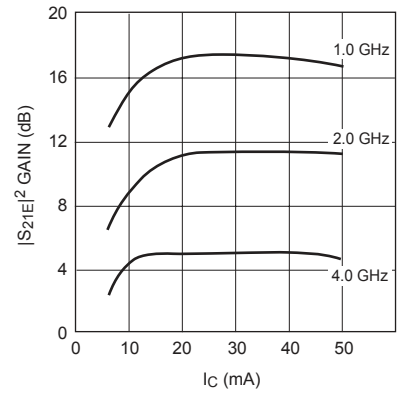

**Figure 3. Insertion Power Gain vs. Collector Current and Frequency.  $V_{CE} = 8\text{ V}$ .**

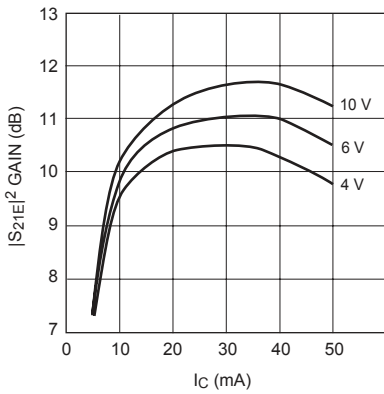

**Figure 4. Insertion Power Gain vs. Collector Current and Voltage.  $f = 2.0\text{ GHz}$ .**

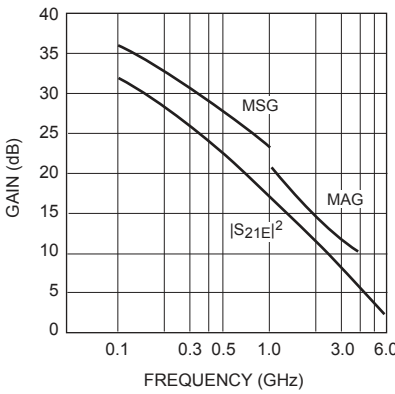

**Figure 5. Insertion Power Gain, Maximum Available Gain and Maximum Stable Gain vs. Frequency.  $V_{CE} = 8\text{ V}$ ,  $I_C = 35\text{ mA}$ .**

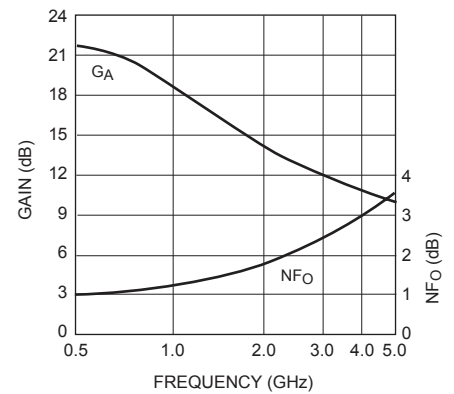

**Figure 6. Noise Figure and Associated Gain vs. Frequency.  $V_{CE} = 8\text{ V}$ ,  $I_C = 10\text{ mA}$ .**

### AT-42000 Typical Scattering Parameters,

Common Emitter,  $Z_O = 50\Omega$ ,  $T_A = 25^\circ\text{C}$ ,  $V_{CE} = 8\text{ V}$ ,  $I_C = 10\text{ mA}$

| Freq.<br>GHz | $S_{11}$ |      | dB   | $S_{21}$ |      | dB    | $S_{12}$ |      | $S_{22}$ |      |
|--------------|----------|------|------|----------|------|-------|----------|------|----------|------|
|              | Mag.     | Ang. |      | Mag.     | Ang. |       | Mag.     | Ang. | Mag.     | Ang. |
| 0.1          | .70      | -50  | 28.0 | 25.19    | 155  | -37.7 | .013     | 71   | .92      | -14  |
| 0.5          | .67      | -136 | 20.9 | 11.04    | 108  | -30.5 | .030     | 43   | .57      | -27  |
| 1.0          | .66      | -166 | 15.7 | 6.08     | 90   | -28.9 | .036     | 47   | .50      | -24  |
| 1.5          | .66      | -173 | 12.1 | 4.02     | 86   | -28.2 | .039     | 52   | .48      | -23  |
| 2.0          | .66      | 179  | 9.8  | 3.09     | 82   | -27.5 | .042     | 57   | .47      | -23  |
| 2.5          | .67      | 170  | 7.8  | 2.46     | 74   | -26.0 | .050     | 66   | .47      | -23  |
| 3.0          | .67      | 165  | 6.3  | 2.08     | 68   | -24.7 | .058     | 72   | .47      | -26  |
| 3.5          | .70      | 157  | 5.1  | 1.80     | 61   | -23.4 | .068     | 77   | .47      | -28  |
| 4.0          | .70      | 151  | 3.9  | 1.56     | 57   | -21.8 | .081     | 82   | .48      | -30  |
| 4.5          | .71      | 145  | 2.9  | 1.40     | 51   | -20.7 | .092     | 86   | .50      | -34  |
| 5.0          | .73      | 138  | 1.9  | 1.24     | 41   | -19.3 | .109     | 87   | .51      | -38  |
| 5.5          | .74      | 132  | 1.2  | 1.15     | 36   | -17.2 | .138     | 88   | .51      | -50  |
| 6.0          | .76      | 129  | 0.2  | 1.02     | 32   | -16.3 | .154     | 87   | .53      | -56  |

### AT-42000 Typical Scattering Parameters,

Common Emitter,  $Z_O = 50\Omega$ ,  $T_A = 25^\circ\text{C}$ ,  $V_{CE} = 8\text{ V}$ ,  $I_C = 35\text{ mA}$

| Freq.<br>GHz | $S_{11}$ |      | dB   | $S_{21}$ |      | dB    | $S_{12}$ |      | $S_{22}$ |      |
|--------------|----------|------|------|----------|------|-------|----------|------|----------|------|
|              | Mag.     | Ang. |      | Mag.     | Ang. |       | Mag.     | Ang. | Mag.     | Ang. |
| 0.1          | .49      | -96  | 33.0 | 44.61    | 143  | -40.9 | .009     | 65   | .79      | -24  |
| 0.5          | .62      | -163 | 22.8 | 13.87    | 98   | -34.4 | .019     | 58   | .42      | -26  |
| 1.0          | .63      | 179  | 17.2 | 7.25     | 86   | -30.5 | .030     | 70   | .38      | -22  |
| 1.5          | .63      | 171  | 13.5 | 4.74     | 78   | -27.7 | .041     | 76   | .38      | -23  |
| 2.0          | .65      | 163  | 11.2 | 3.62     | 72   | -25.4 | .054     | 79   | .38      | -25  |
| 2.5          | .65      | 159  | 9.3  | 2.90     | 67   | -23.6 | .066     | 82   | .38      | -27  |
| 3.0          | .68      | 154  | 7.8  | 2.44     | 60   | -22.1 | .079     | 82   | .38      | -29  |
| 3.5          | .67      | 148  | 6.5  | 2.12     | 57   | -20.6 | .093     | 84   | .39      | -32  |
| 4.0          | .69      | 144  | 5.3  | 1.83     | 51   | -19.7 | .104     | 86   | .40      | -34  |
| 4.5          | .70      | 139  | 4.4  | 1.65     | 47   | -18.3 | .121     | 86   | .41      | -40  |
| 5.0          | .70      | 137  | 3.3  | 1.46     | 43   | -17.5 | .133     | 85   | .42      | -44  |
| 5.5          | .72      | 131  | 2.7  | 1.36     | 38   | -16.5 | .149     | 86   | .41      | -48  |
| 6.0          | .74      | 128  | 1.7  | 1.22     | 34   | -15.7 | .164     | 85   | .44      | -55  |

A model for this device is available in the DEVICE MODELS section.

### AT-42000 Noise Parameters:

$V_{CE} = 8\text{ V}$ ,  $I_C = 10\text{ mA}$

| Freq.<br>GHz | NF <sub>O</sub><br>dB | G <sub>opt</sub> |      | R <sub>N</sub> /50 |
|--------------|-----------------------|------------------|------|--------------------|
|              |                       | Mag              | Ang  |                    |
| 0.1          | 1.0                   | .04              | 13   | 0.13               |
| 0.5          | 1.1                   | .05              | 69   | 0.13               |
| 1.0          | 1.5                   | .09              | 127  | 0.12               |
| 2.0          | 1.9                   | .23              | 171  | 0.11               |
| 4.0          | 3.0                   | .47              | -154 | 0.14               |

## AT-42000 Chip Dimensions

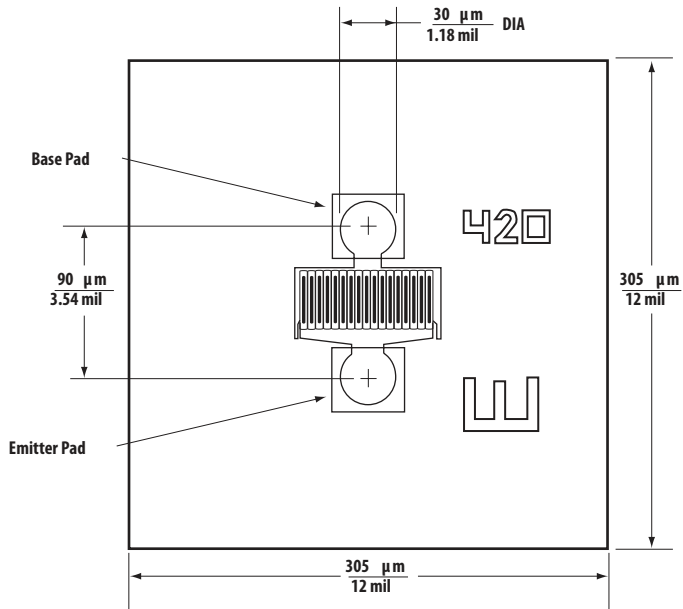

Note: Die thickness is 5 to 6 mil.

For product information and a complete list of distributors, please go to our web site: [www.avagotech.com](http://www.avagotech.com)

Avago, Avago Technologies, and the A logo are trademarks of Avago Technologies, Limited in the United States and other countries. Data subject to change. Copyright © 2008 Avago Technologies Limited. All rights reserved. Obsoletes 5965-8909E AV02-1002EN - January 16, 2008

**Avago**  
TECHNOLOGIES