

# RFM15N05/15N06 RFP15N05/15N06

N-Channel Enhancement Mode  
Power Field Effect Transistors

May 1992

### Features

- 15A, 50V and 60V
- $r_{DS(on)} = 0.14\Omega$
- SOA is Power-Dissipation Limited
- Nanosecond Switching Speeds
- Linear Transfer Characteristics
- High Input Impedance
- Majority Carrier Device
- Temperature Compensated SPICE Model Provided

### Description

The RFM15N05 and RFM15N06 and the RFP15N05 and RFP15N06 are n-channel enhancement-mode silicon-gate power field-effect transistors designed for applications such as switching regulators, switching converters, motor drivers, relay drivers, and drivers for high-power bipolar switching transistors requiring high speed and low gate-drive power. These types can be operated directly from integrated circuits.

The RFM series types are supplied in the JEDEC TO-204AA steel package and the RFP series types in the TO-220AB plastic package.

### Packages

TO-204AA  
BOTTOM VIEW

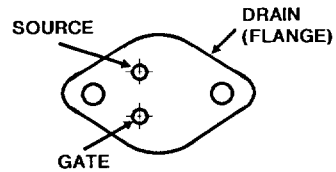

TO-220AB  
TOP VIEW

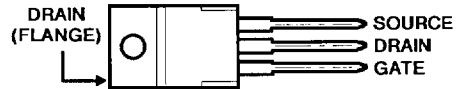

### Terminal Diagram

N-CHANNEL ENHANCEMENT MODE

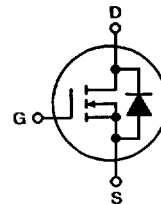

### Absolute Maximum Ratings ( $T_C = 25^\circ\text{C}$ ), Unless Otherwise Specified

	RFM15N05	RFM15N06	RFP15N05	RFP15N06	UNITS	
Drain-Source Voltage .....	$V_{DSS}$	50	60	50	60	V
Drain-Gate Voltage ( $R_{GS} = 1\text{m}\Omega$ ) .....	$V_{DGR}$	50	60	50	60	V
Continuous Drain Current						
RMS Continuous .....	$I_D$	15	15	15	15	A
Pulsed Drain Current .....	$I_{DM}$	40	40	40	40	A
Gate-Source Voltage .....	$V_{GS}$	$\pm 20$	$\pm 20$	$\pm 20$	$\pm 20$	V
Maximum Power Dissipation						
$T_C = +25^\circ\text{C}$ .....	$P_D$	90	90	90	90	W
Above $T_C = +25^\circ\text{C}$ , Derate Linearly .....		0.48	0.48	0.48	0.48	W/ $^\circ\text{C}$
Operating and Storage Junction .....	$T_J, T_{STG}$	-55 to +150	-55 to +150	-55 to +150	-55 to +150	$^\circ\text{C}$
Temperature Range						

**RFM15N05, RFM15N06, RFP15N05, RFP15N06**

**ELECTRICAL CHARACTERISTICS, At Case Temperature ( $T_c$ )=25°C unless otherwise specified**

CHARACTERISTIC	SYMBOL	TEST CONDITIONS	LIMITS				UNITS
			RFM15N05 RFP15N05		RFM15N06 RFP15N06		
			Min.	Max.	Min.	Max.	
Drain-Source Breakdown Voltage	$V_{DSS}$	$I_D=1\text{ mA}$ $V_{GS}=0$	50	—	60	—	V
Gate-Threshold Voltage	$V_{GS(th)}$	$V_{GS}=V_{DS}$ $I_D=1\text{ mA}$	2	4	2	4	V
Zero-Gate Voltage Drain Current	$I_{DSS}$	$V_{DS}=40\text{ V}$	—	1	—	—	$\mu\text{A}$
		$V_{DS}=50\text{ V}$	—	—	—	1	
		$T_C=125^\circ\text{ C}$ $V_{DS}=40\text{ V}$ $V_{DS}=50\text{ V}$	—	50	—	—	
Gate-Source Leakage Current	$I_{GSS}$	$V_{GS}=\pm 20\text{ V}$ $V_{DS}=0$	—	100	—	100	nA
Drain-Source On Voltage	$V_{DS(on)}^a$	$I_D=7.5\text{ A}$ $V_{GS}=10\text{ V}$	—	1.05	—	1.05	V
		$I_D=15\text{ A}$ $V_{GS}=10\text{ V}$	—	2.5	—	2.5	
Static Drain-Source On Resistance	$r_{DS(on)}^a$	$I_D=7.5\text{ A}$ $V_{GS}=10\text{ V}$	—	0.14	—	0.14	$\Omega$
Forward Transconductance	$g_{fs}^a$	$V_{DS}=10\text{ V}$ $I_D=7.5\text{ A}$	2	—	2	—	mho
Input Capacitance	$C_{iss}$	$V_{DS}=25\text{ V}$ $V_{GS}=0\text{ V}$ $f=1\text{ MHz}$	—	850	—	850	$\mu\text{F}$
Output Capacitance	$C_{oss}$		—	450	—	450	
Reverse-Transfer Capacitance	$C_{rss}$		—	180	—	180	
Turn-On Delay Time	$t_d(on)$	$V_{DD}=30\text{ V}$ $I_D=7.5\text{ A}$ $R_{\theta en}=R_{\theta s}=50\ \Omega$ $V_{GS}=10\text{ V}$	16(typ)	40	16(typ)	40	ns
Rise Time	$t_r$		100(typ)	175	100(typ)	175	
Turn-Off Delay Time	$t_d(off)$		72(typ)	175	72(typ)	175	
Fall Time	$t_f$		66(typ)	140	66(typ)	140	
Thermal Resistance Junction-to-Case	$R_{\theta jc}$		RFM15N05, RFM15N06	—	1.67	—	
		RFP15N05, RFP15N06	—	1.67	—	1.67	

<sup>a</sup>Pulsed: Pulse duration=300  $\mu\text{s}$  max., duty cycle 2%

**4**  
**N-CHANNEL  
POWER MOSFETS**

**SOURCE-DRAIN DIODE RATINGS AND CHARACTERISTICS**

CHARACTERISTIC	SYMBOL	TEST CONDITIONS	LIMITS				UNITS
			RFM15N05 RFP15N05		RFM15N06 RFP15N06		
			MIN.	MAX.	MIN.	MAX.	
Diode Forward Voltage	$V_{SD}$	$I_{SD}=15\text{ A}$	—	1.4	—	1.4	V
Reverse Recovery Time	$t_{rr}$	$I_F=4\text{ A}$ $d_{IF}/d_t=100\text{ A}/\mu\text{s}$	100 (typ)		100(typ)		ns

\*Pulse Test: Width  $\leq 300\ \mu\text{s}$ , duty cycle  $\leq 2\%$ .

**RFM15N05, RFM15N06, RFP15N05, RFP15N06**

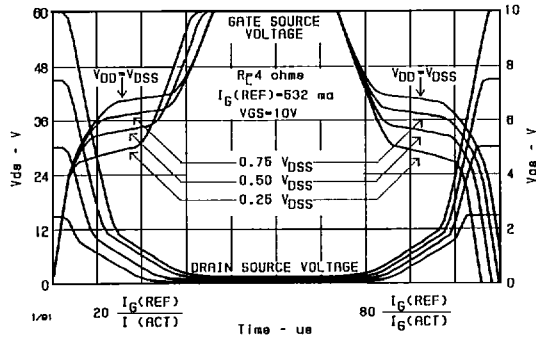

**FIGURE 1. NORMALIZED SWITCHING WAVEFORMS**

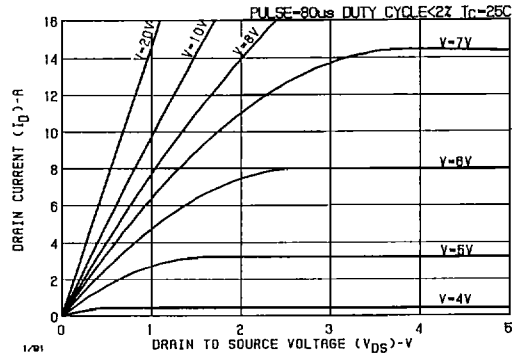

**FIGURE 2. TYPICAL SATURATION CHARACTERISTICS**

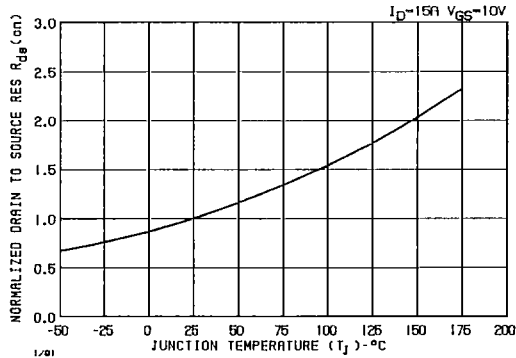

**FIGURE 3. NORMALIZED  $r_{DS(ON)}$  vs TEMPERATURE**

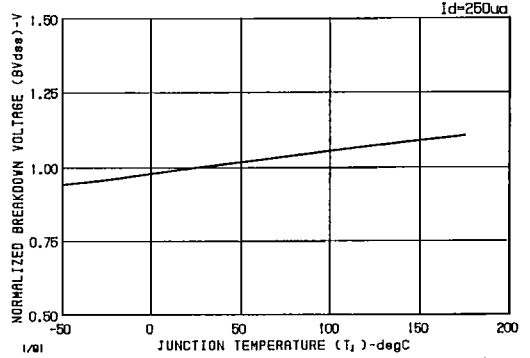

**FIGURE 4. BREAKDOWN VOLTAGE vs TEMPERATURE**

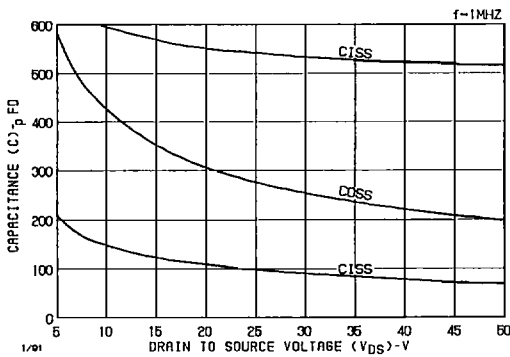

**FIGURE 5. CAPACITANCE vs DRAIN TO SOURCE VOLTAGE**

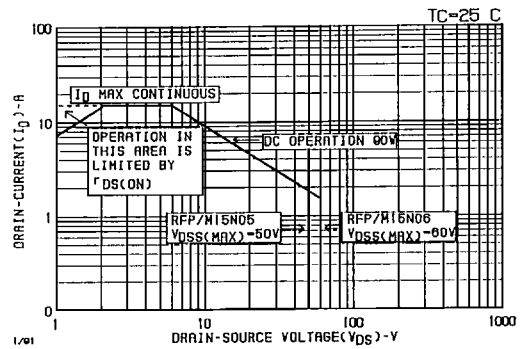

**FIGURE 6. MAXIMUM SAFE OPERATING AREA**

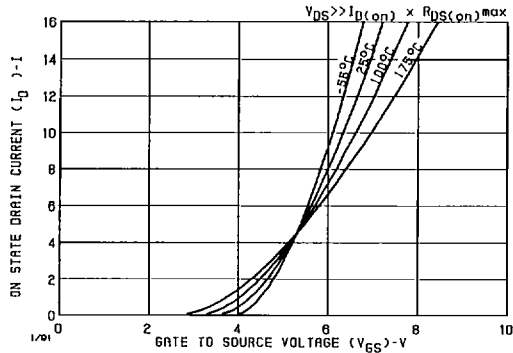

FIGURE 7. TYPICAL TRANSFER CHARACTERISTICS

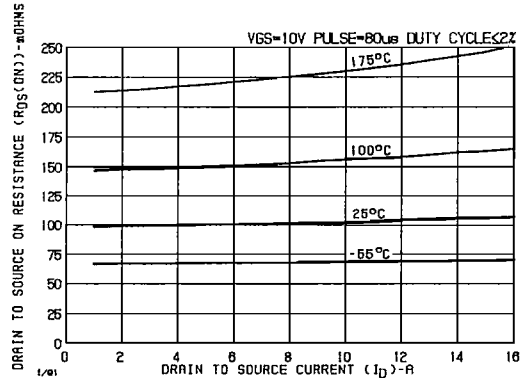

FIGURE 8.  $r_{DS(ON)}$  vs DRAIN CURRENT

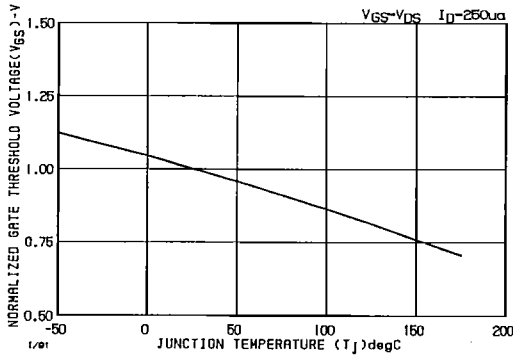

FIGURE 9. THRESHOLD VOLTAGE vs TEMPERATURE ( $T_J$ )

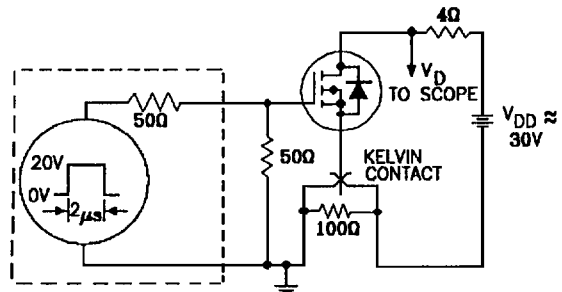
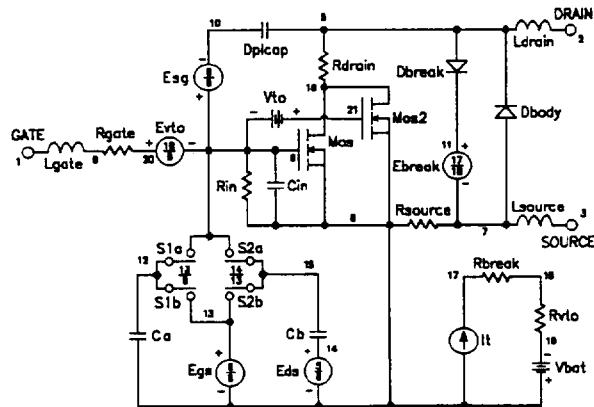

FIGURE 10. SWITCHING TIME TEST CIRCUIT

RFM15N05, RFM15N06, RFP15N05, RFP15N06

Spice Model (RFM15N06)

```
.SUBCKT RFM15N06 2 1 3; rev 01/07/91
*Nominal Temperature = 25°C
.MODEL MOSMOD NMOS (VTO=3.46 KP=3.09 IS=1e-30 N=10 TOS=1 L=lu W=lu)
Vto 21 6 .74
Rsource 8 7 RDSMOD 34.82e-3
Rdrain 5 16 RDSMOD 13.3e-3
.MODEL RDSMOD RES (TC1=6.5e-3 TC2=3.28e-5)
.MODEL RVTOMOD RES (TC1=-4.30e-3 TC2=-3.77e-6)
.MODEL RVTOMOD2 RES (TC1=0 TC2=0)
Ebreak 11 7 17 18 102.35
.MODEL RBKMOD RES (TC1=8.33e-1 TRS1=7.81e-4 TRS2=-9.28e-6)
.MODEL DBKMOD D (RS=3.83e-1 TRS1=7.81e-4 TRS2=-9.28e-6)
.MODEL DBDMOD D (IS=8.16e-13 RS=1.54e-2 TRS1=1.77e-3 TRS2=1.85e-5)
+CJO=9.16e-10 TT=7e-8
Cin 6 8 4.44e-10
Ca 12 8 9.14e-10
.MODEL S1AMOD VSWITCH (RON=1e-5 ROFF=0.1 VON=-3.66 VOFF=-1.66)
.MODEL S1BMOD VSWITCH (RON=1e-5 ROFF=0.1 VON=-1.66 VOFF=-3.66)
.MODEL DPLCAPMOD D (CJO=4.90e-10 IS=1e-30 N=10)
Cb 12 14 5.81e-10
.MODEL S2AMOD VSWITCH (RON=1e-5 ROFF=0.1 VON=3.07 VOFF=8.07)
.MODEL S2BMOD VSWITCH (RON=1e-5 ROFF=0.1 VON8.07 VOFF=3.07)
Rgate 9 20 20.43
Lgate 1 9 1.32e-8
Ldrain 2 5 1.0e-10
Lsource 3 7 1.68e-8
Dbody 7 5 DBDMOD
Dbreak 5 11 DBKMOD
Dplcap 10 5 DPLCAPMOD
Eds 14 8 5 8 1
Egs 13 8 6 8 1
Esg 6 10 6 8 1
Evt0 20 6 18 8 1
It 8 17 1
Mos 16 6 8 8 MOSMOD M=0.99
MOS2 16 21 8 8 MOSMOD M=0.01
Rbreak 17 18 RBKMOD 1
Rin 6 8 1e9
Rvto 18 19 RVTOMOD 1
S1a 6 12 13 8 S1AMOD
S1b 13 12 13 8 S1BMOD
S2a 6 15 14 13 S2AMOD
S2b 13 15 14 13 S2BMOD
Vbat 8 19 DC 1
.ENDS
```



Spice Model (RFM15N06)

```
.SUBCKT RFM15N06 2 1 3; rev 01/07/91
*Nominal Temperature = 25°C
.MODEL MOSMOD NMOS (VTO=3.46 KP=3.09 IS=1e-30 N=10 TOS=1 L=lu W=lu)
Vto 21 6 .74
Rsource 8 7 RDSMOD 34.82e-3
Rdrain 5 16 RDSMOD 13.3e-3
.MODEL RDSMOD RES (TC1=6.5e-3 TC2=3.28e-5)
.MODEL RVTOMOD RES (TC1=-4.30e-3 TC2=-3.77e-6)
.MODEL RVTOMOD2 RES (TC1=0 TC2=0)
Ebreak 11 7 17 18 102.35
.MODEL RBKMOD RES (TC1=8.33e-1 TRS1=7.81e-4 TRS2=-9.28e-6)
.MODEL DBKMOD D (RS=3.83e-1 TRS1=7.81e-4 TRS2=-9.28e-6)
.MODEL DBDMOD D (IS=8.16e-13 RS=1.54e-2 TRS1=1.77e-3 TRS2=1.85e-5 +CJO=9.16e-10 TT=7e-8)
Cin 6 8 4.44e-10
Ca 12 8 9.14e-10
.MODEL S1AMOD VSWITCH (RON=1e-5 ROFF=0.1 VON=-3.66 VOFF=-1.66)
.MODEL S1BMOD VSWITCH (RON=1e-5 ROFF=0.1 VON=-1.66 VOFF=-3.66)
.MODEL DPLCAPMOD D (CJO=4.90e-10 IS=1e-30 N=10)
Cb 12 14 5.81e-10
.MODEL S2AMOD VSWITCH (RON=1e-5 ROFF=0.1 VON=3.07 VOFF=8.07)
.MODEL S2BMOD VSWITCH (RON=1e-5 ROFF=0.1 VON=8.07 VOFF=3.07)
Rgate 9 20 20.43
Lgate 1 9 1.32e-8
Ldrain 2 5 1.0e-10
Lsource 3 7 1.68e-8
Dbody 7 5 DBDMOD
Dbreak 5 11 DBKMOD
Dplcap 10 5 DPLCAPMOD
Eds 14 8 5 8 1
Egs 13 8 6 8 1
Esg 6 10 6 8 1
Evt0 20 6 18 8 1
It 8 17 1
Mos 16 6 8 8 MOSMOD M=0.99
MOS2 16 21 8 8 MOSMOD M=0.01
Rbreak 17 18 RBKMOD 1
Rin 6 8 1e9
Rvto 18 19 RVTOMOD 1
S1a 6 12 13 8 S1AMOD
S1b 13 12 13 8 S1BMOD
S2a 6 15 14 13 S2AMOD
S2b 13 15 14 13 S2BMOD
Vbat 8 19 DC 1
.ENDS
```

