

NOTES:

1. MATERIALS:
HOUSING - LCP, 30% GLASS FILLED, 94-V0, BLACK.
TERMINALS - PHOSPHOR BRONZE.
METAL FORKLOCKS - PHOSPHOR BRONZE.
2. FINISH:
TERMINALS - .000030/0.00076 MINIMUM GOLD IN THE CONTACT AREA AND .000075/0.0019 MINIMUM TIN IN SOLDER TAIL AREA OVER .000050/0.0013 MINIMUM NICKEL OVERALL.
METAL FORKLOCKS - .00008/0.002 MINIMUM TIN OVERALL.
3. PRODUCT SPECIFICATION PS-71109-9999 APPLIES.
4. CARD SLOT ACCEPTS .062 +.007/-.005 P.C. BOARD.
5. THE RECOMMENDED PLATING SPECIFICATION FOR THE MATING PC BOARD IS .000030/0.0076 MINIMUM GOLD OVER .000075/0.0019 MINIMUM NICKEL.
6. MOLEX LOGO SHALL APPEAR ON BOTH SIDES OF HOUSING, AND LOCATED APPROXIMATELY AS SHOWN.
7. FOUR DIGIT DATE CODE (YR/WK) SHALL BE LOCATED APPROXIMATELY AS SHOWN.
8. THE PRIMARY SHIPPING CARTON WILL BE LABELED "COMPLIANT TO ROHS DIRECTIVE 2002/95/EC AND ELV ANNEX II OF DIRECTIVE 2000/53/EC". CARTONS WITHOUT THIS LABEL MAY CONTAIN PRODUCT WITH LEAD.

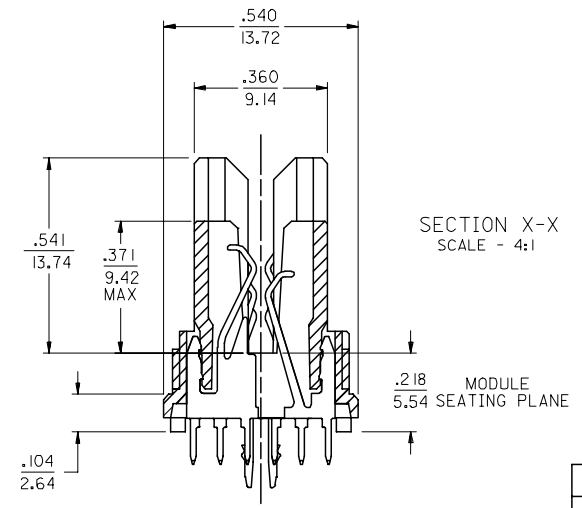
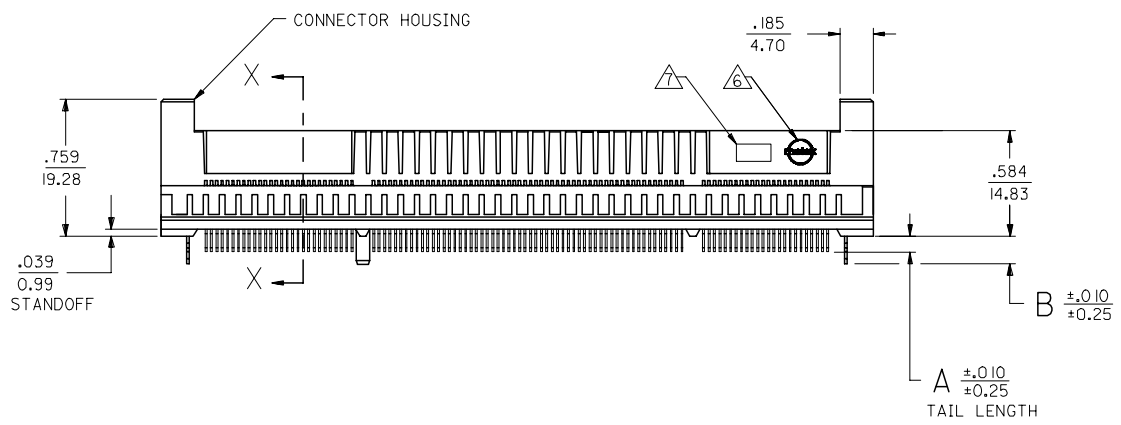
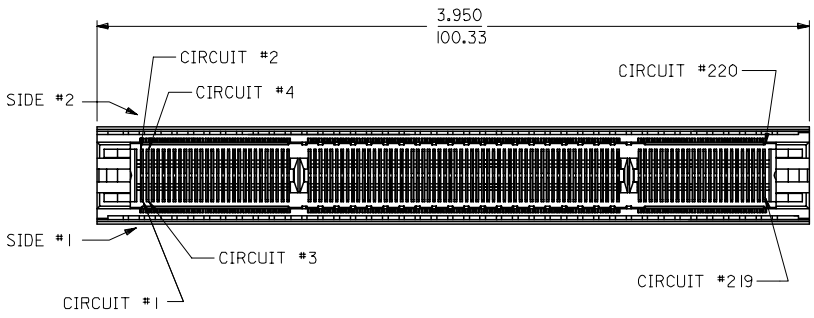

71109-5003	.140/3.56	.155/3.94
71109-5002	.115/2.92	.155/3.94
71109-5001	.090/2.29	.155/3.94
MAT'L NUMBER	A	B

MODIFY 71109-5003 EC NO: UCP2006-1372	2005/12/19	DRW:MS/BARRA
2006/01/05	CHKD:DMORGAN	2006/01/05
2006/01/06	APPR:SMILLER	2006/01/06
REV	DESCRIPTION	

QUALITY SYMBOLS	GENERAL TOLERANCES (UNLESS SPECIFIED)
▽=0	mm INCH
▽=0	4 PLACES ± --- ± ---
	3 PLACES ± --- ±.005
	2 PLACES ±.013 ± ---
	1 PLACE ± --- ± ---
	ANGULAR ±1/2°
	DRAFT WHERE APPLICABLE MUST REMAIN WITHIN DIMENSIONS

DRAWN BY	DATE	TITLE
NELSON	1997/06/20	SALES ASSEMBLY
CHECKED BY	DATE	220 CKT HISPEC CONNECTOR
NELSON	1997/06/20	W/ METAL FORKLOCKS
APPROVED BY	DATE	
FUNCK	1997/06/20	
MATERIAL NO.	DOCUMENT NO.	
SEE TABLE	SD-71109-502	

SCALE	DESIGN UNITS	THIRD ANGLE PROJECTION
2:1	INCH	
MOLEX INCORPORATED		
SHEET NO.	1 OF 2	

2	D
1	H
SHT	REV

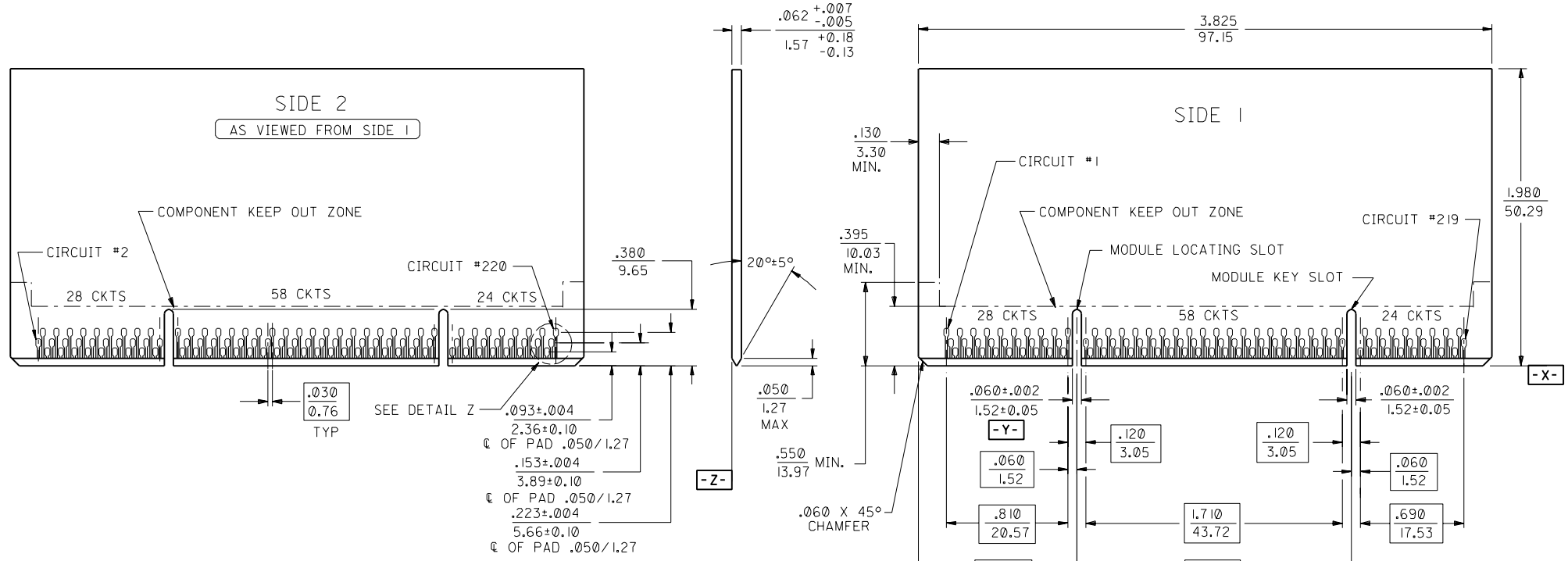

RECOMMENDED MODULE BOARD LAYOUT

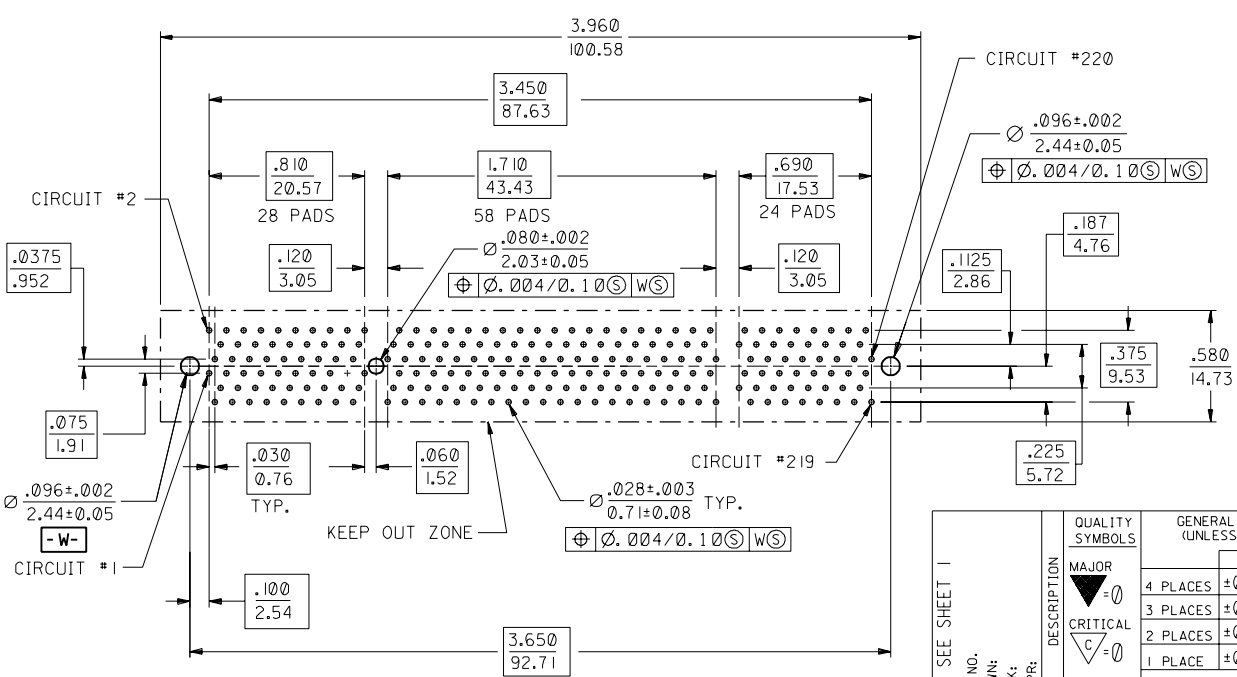

RECOMMENDED PCB HOLE LAYOUT

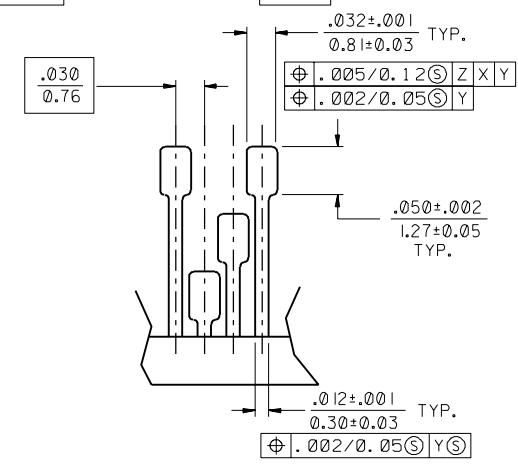

DETAIL Z

SEE SHEET 1	QUALITY SYMBOLS MAJOR $\nabla = 0$ CRITICAL $\nabla C = 0$	GENERAL TOLERANCES: (UNLESS SPECIFIED)		SCALE 2 : 1	DESIGN UNITS <input type="checkbox"/> mm <input checked="" type="checkbox"/> INCH	THIRD ANGLE PROJECTION <input type="checkbox"/> mm <input checked="" type="checkbox"/> INCH <input type="checkbox"/> ONLY	DIMENSIONS: <input type="checkbox"/> mm <input checked="" type="checkbox"/> INCH <input type="checkbox"/> ONLY		SHT	REV	
		4 PLACES ±0.	±.	DRAWN BY & DATE NELSON 06/20/97	TITLE: SALES ASSEMBLY 220 CKT "HiSpec" CONNECTOR THRU-HOLE W/ METAL FORKLLOCKS		REVISE ON CAD ONLY				
D	REV	DRAWN BY & DATE NELSON 06/20/97		CHECKED BY & DATE NELSON 06/20/97		APPROVED BY & DATE FUNCK 06/20/97		MATERIAL NO. SEE TABLE		DRAWING NO. SD-71109-502	SHEET NO. 2
		DRAFT WHERE APPLICABLE MUST REMAIN WITHIN DIMENSIONS		CAD FILENAME S7110963.S02		THIS DRAWING CONTAINS INFORMATION THAT IS PROPRIETARY TO MOLEX INCORPORATED AND SHOULD NOT BE USED WITHOUT WRITTEN PERMISSION.		SIZE C			