

Product number
SEE TABLE, SHEET 5

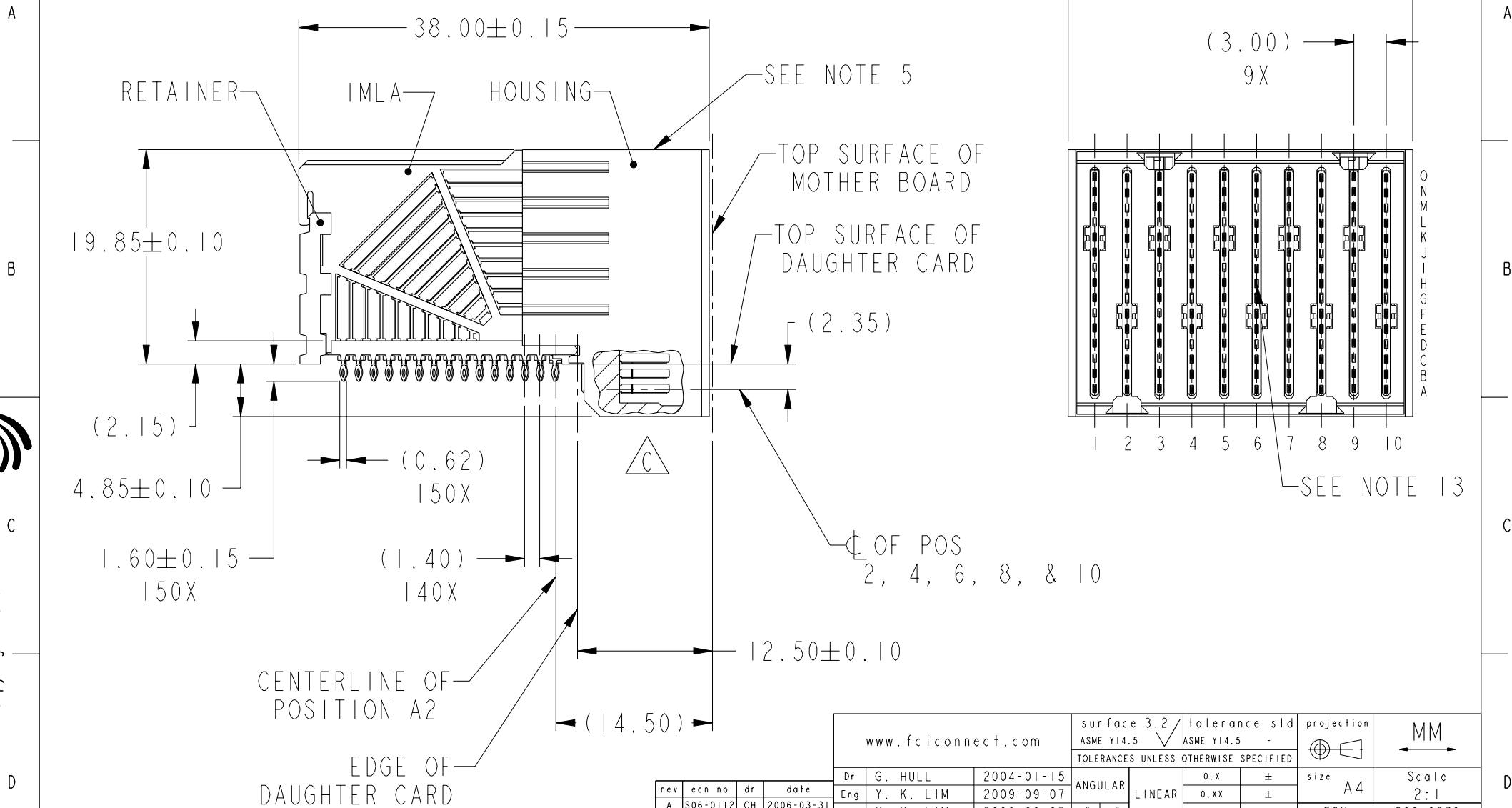

Copyright FCI.

rev	ecn no	dr	date
A	S06-0112	CH	2006-03-31
B	S06-0374	DG	2006-12-21
C	S09-0279	YK	2009-09-07
-	-	-	-
-	-	-	-
-	-	-	-

www.fciconnect.com		surface 3.2 ASME Y14.5	tolerance std ASME Y14.5	projection MM
Dr	G. HULL	2004-01-15	TOLERANCES UNLESS OTHERWISE SPECIFIED	MM
Eng	Y. K. LIM	2009-09-07	ANGULAR	Scale 2:1
Chr	Y. K. LIM	2009-09-07	LINEAR	size A4
Appr	JOEY NG	2009-09-07	0.X ±	ECN S09-0279
			0.XX ±	Spec ref
			0.XXX ±	Product family AirMax VS
				catalog no
				CUSTOMER
				sheet 1 of 5
FCI logo			AirMax VS R/A HEADER ASSY PRESS-FIT, 150 POS, 32MM	dwg no 10037324
				Rev. C

REV F - 2006-04-17

DESCRIPTION	DIM A	DIM B	DIM C
2-32MM MODULES PLACED END-TO-END	5.00	31.90 2X	32.00
1-30MM MODULE & 1-32MM MODULE PLACED END-TO-END	4.00	29.90 1X & 31.90 1X	31.00

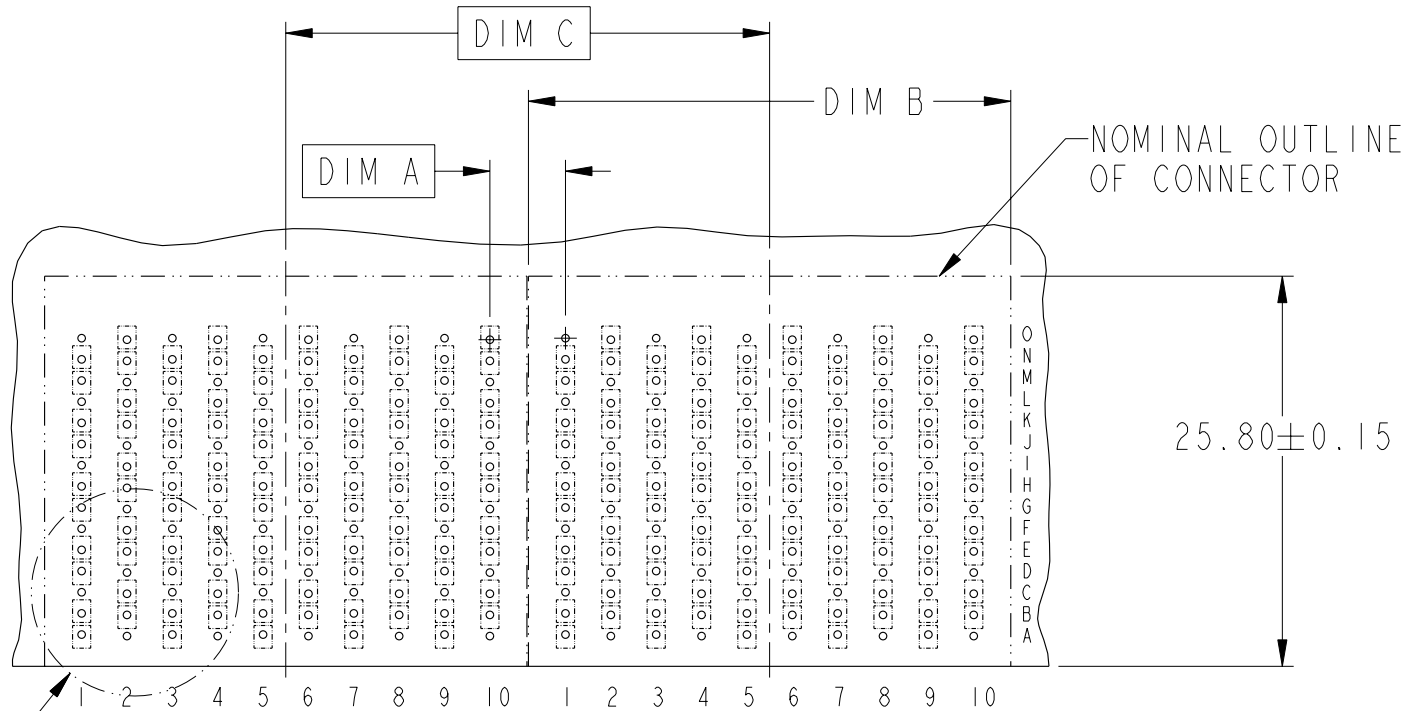

DETAIL A
 RECOMMENDED PCB LAYOUT
 FOR DIFFERENTIAL APPLICATIONS
 COMPONENT SIDE
 (TWO ADJACENT FOOTPRINTS SHOWN)
 NOTES 6 & 7

	title AirMax VS R/A HEADER ASSY PRESS-FIT, 150 POS, 32MM	dwg no 10037324	Rev. C
	catalog no -	CUSTOMER	sheet 2 of 5

Copyright FCI.
 FCI

DESCRIPTION	DIM D	DIM E	DIM F
2-32MM MODULES PLACED END-TO-END	5.00	31.90 2X	32.00
1-30MM MODULE & 1-32MM MODULE PLACED END-TO-END	4.00	29.90 1X & 31.90 1X	31.00

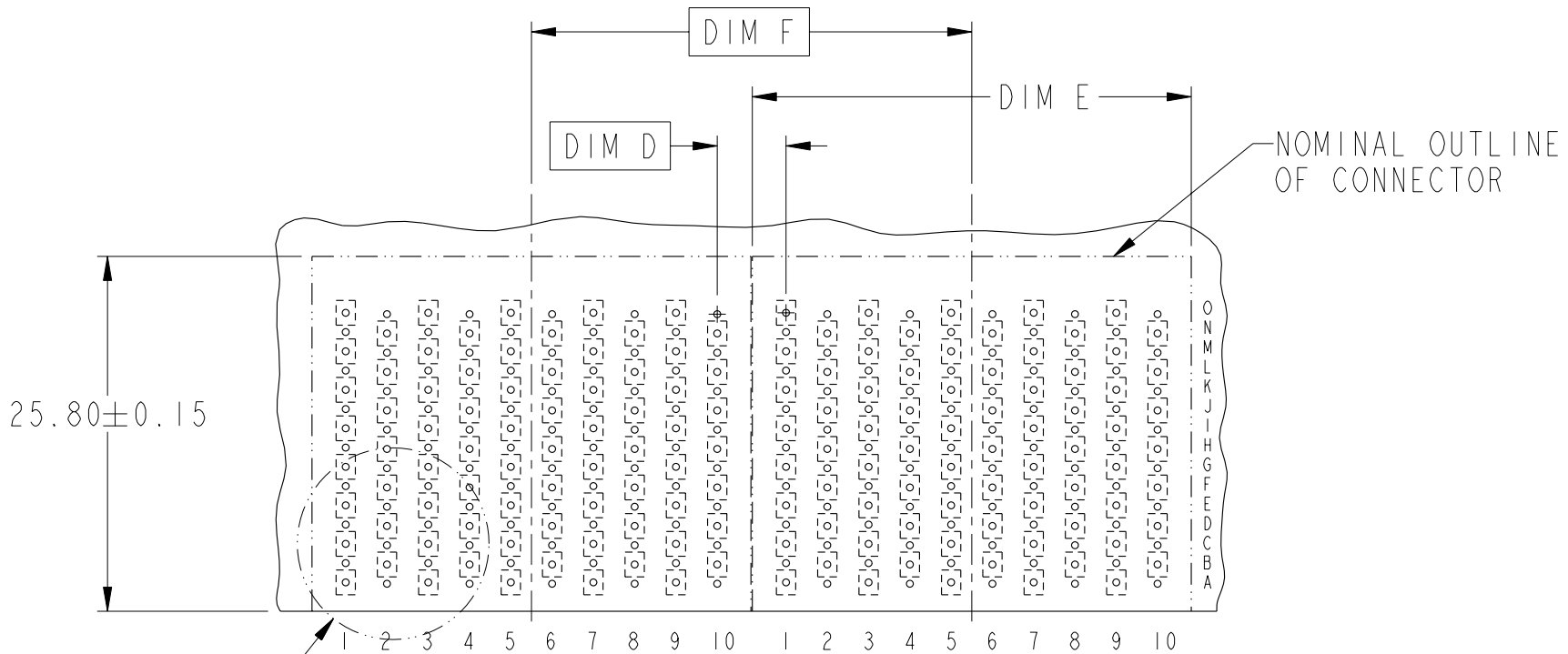

DETAIL B

RECOMMENDED PCB LAYOUT
FOR SINGLE ENDED APPLICATIONS
COMPONENT SIDE
(TWO ADJACENT FOOTPRINTS SHOWN)
NOTES 6 & 7



title AirMax VS R/A HEADER ASSY
PRESS-FIT, 150 POS, 32MM
catalog no -

dwg no 10037324

Rev. C

CUSTOMER sheet 3 of 5



Copyright FCI.

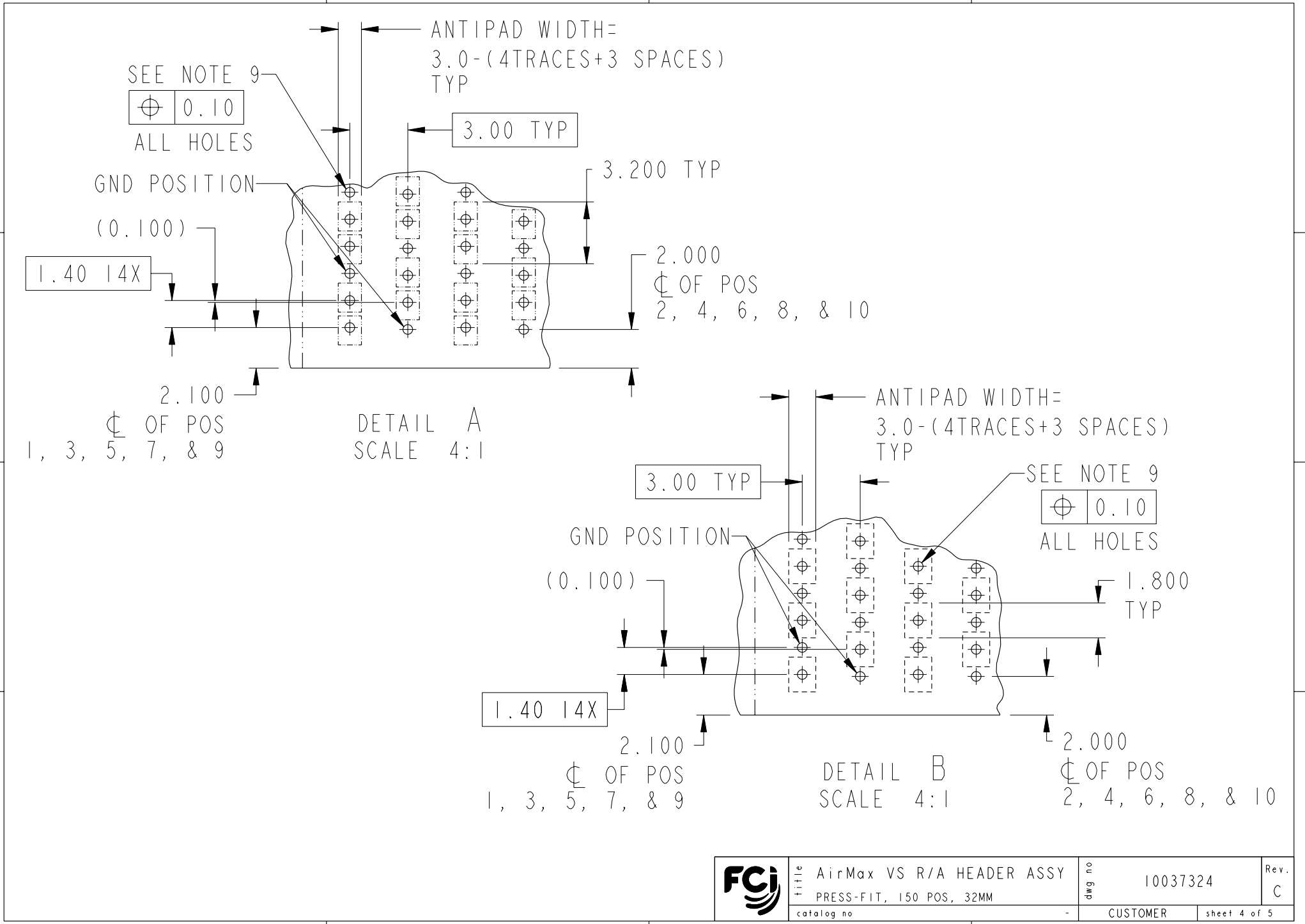

REV F - 2006-04-17



Part no AirMax VS R/A HEADER ASSY
 PRESS-FIT, 150 POS, 32MM
 catalog no -

dwg no 10037324
 CUSTOMER sheet 4 of 5

Rev. C

PDM: Rev:C

STATUS: Released

Printed: Dec 01, 2010

PART NUMBER	PRESS-FIT TAIL PLATING TYPE	SHORT DETECT CONTACT
10037324-101	TIN/LEAD ALLOY OVER NICKEL	NO
10037324-101LF	TIN OVER NICKEL (LEAD FREE)	
10037324-111	TIN/LEAD ALLOY OVER NICKEL	YES (SEE NOTE 13)
10037324-111LF	TIN OVER NICKEL (LEAD FREE)	

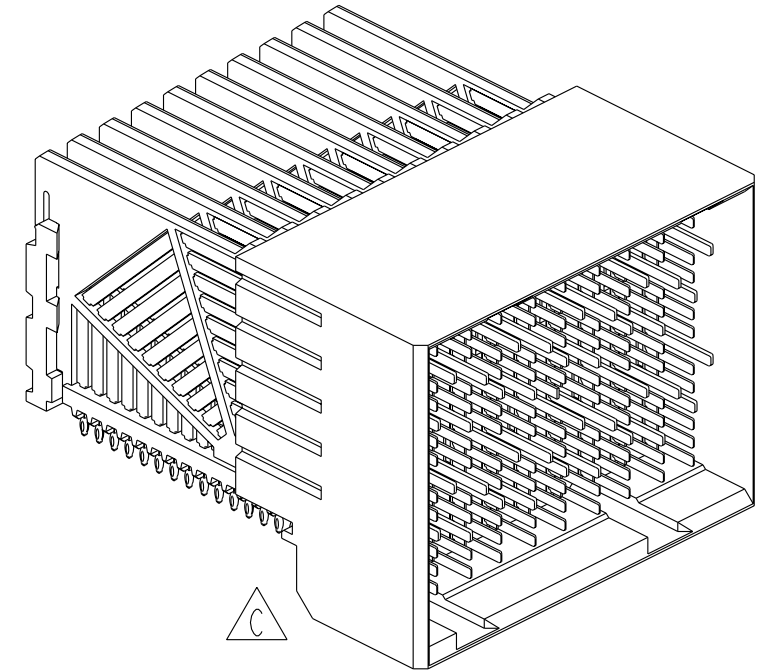

NOTES:

1. CONNECTOR MATERIALS:
HOUSING & RETAINER: HIGH TEMP THERMOPLASTIC, NATURAL, UL94V-0
IMLA PLASTIC: HIGH TEMP THERMOPLASTIC, BLACK, UL94V-0
CONTACT: COPPER ALLOY
2. CONTACT PLATING:
SEPARABLE INTERFACE:
PERFORMANCE-BASED PLATING, QUALIFIED TO MEET THE REQUIREMENTS OF FCI PRODUCT SPECIFICATION GS-12-239 INCLUDING TELCORDIA GR-1217-CORE (NOVEMBER 1995) CENTRAL OFFICE TEST SEQUENCE

PRESS-FIT TAILS: SEE TABLE
3. PRODUCT SPECIFICATION: GS-12-239
4. APPLICATION SPECIFICATION: GS-20-035
5. PRODUCT MARKING, (PART NUMBER & LOT CODE), ON THIS SURFACE
6. REFER TO CUSTOMER DRAWING 10035911 FOR INFORMATION REGARDING PCB LAYOUT OF POWER AND GUIDE MODULES RELATIVE TO SIGNAL MODULES
7. POSITIONS F AND L OF ODD NUMBERED COLUMNS AND POSITIONS G AND M OF EVEN NUMBERED COLUMNS CORRESPOND TO EARLY MATE HEADER PINS
8. THERE IS NO GROUND BUSSING WITHIN THE CONNECTOR SYSTEM
9. REFER TO CUSTOMER DRAWING 10045979 FOR INFORMATION ON PCB HOLE DIAMETERS AND PLATING OPTIONS.
10. LEAD FREE PRODUCT MEETS EUROPEAN UNION DIRECTIVES & OTHER COUNTRY REGULATIONS AS DESCRIBED IN GS-22-008.
11. THE HOUSING WILL WITHSTAND EXPOSURE TO 260°C PEAK TEMPERATURE FOR 40 SECONDS IN A CONVECTION, INFRA-RED OR VAPOR PHASE REFLOW OVEN.
12. PACKAGING MEETS GS-14-920 LEAD FREE LABELING SPECIFICATION.
13. MATING PIN H6 HAS 0.5mm LESS WIPE THAN THE SHORTEST SIGNAL PIN.
14. A  SYMBOL WILL BE NEXT TO ANY DIMENSION, VIEW, OR NOTE WHICH HAS BEEN MODIFIED WITH THE CURRENT DRAWING REVISION.

	title AirMax VS R/A HEADER ASSY PRESS-FIT, 150 POS, 32MM	dwg no 10037324	Rev. C
	catalog no -	CUSTOMER	sheet 5 of 5



Copyright FCI.