

## Low voltage stepper motor driver expansion board based on the STSPIN220 for STM32 Nucleo

Data brief

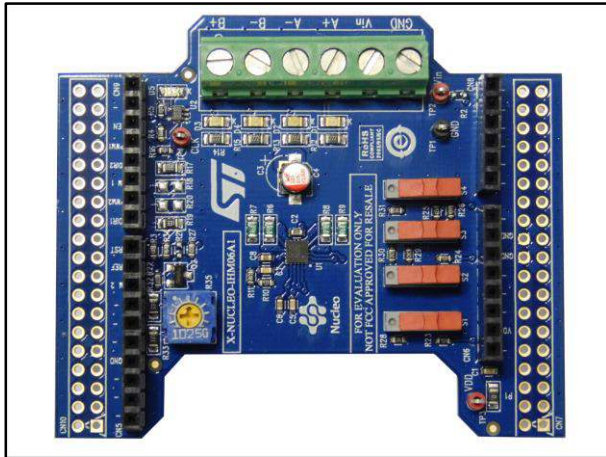

### Description

The X-NUCLEO-IHM06A1 is a low voltage stepper motor driver expansion board based on the STSPIN220 monolithic low voltage driver for low voltage stepper motors. It represents an affordable, easy-to-use solution for driving low voltage stepper motors in your STM32 Nucleo project, implementing portable motor driving applications such as thermal printers, robotics and toys.

It includes a stepper driver able to operate in low voltage (battery) scenarios, allowing zero consumption states. The device implements current control with fixed OFF time and a maximum 1/256 microstep resolution.

The X-NUCLEO-IHM06A1 is compatible with the Arduino UNO R3 connector and supports the addition of other STM32 expansion boards with a single STM32 Nucleo board. You can also mount the ST morpho connector.

### Features

- Low voltage range: 1.8 to 10 V
- Microstep adjustment up to the 256<sup>th</sup> step
- Phase current: up to 1.3 A<sub>RMS</sub>
- Current control with adjustable off-time
- Full protection overcurrent and short circuit protection
- Thermal shutdown
- Compatible with Arduino UNO R3 connector
- Compatible with STM32 Nucleo boards
- RoHS compliant



# Schematic diagram

Figure 1: X-NUCLEO-IHM06A1 schematic diagram

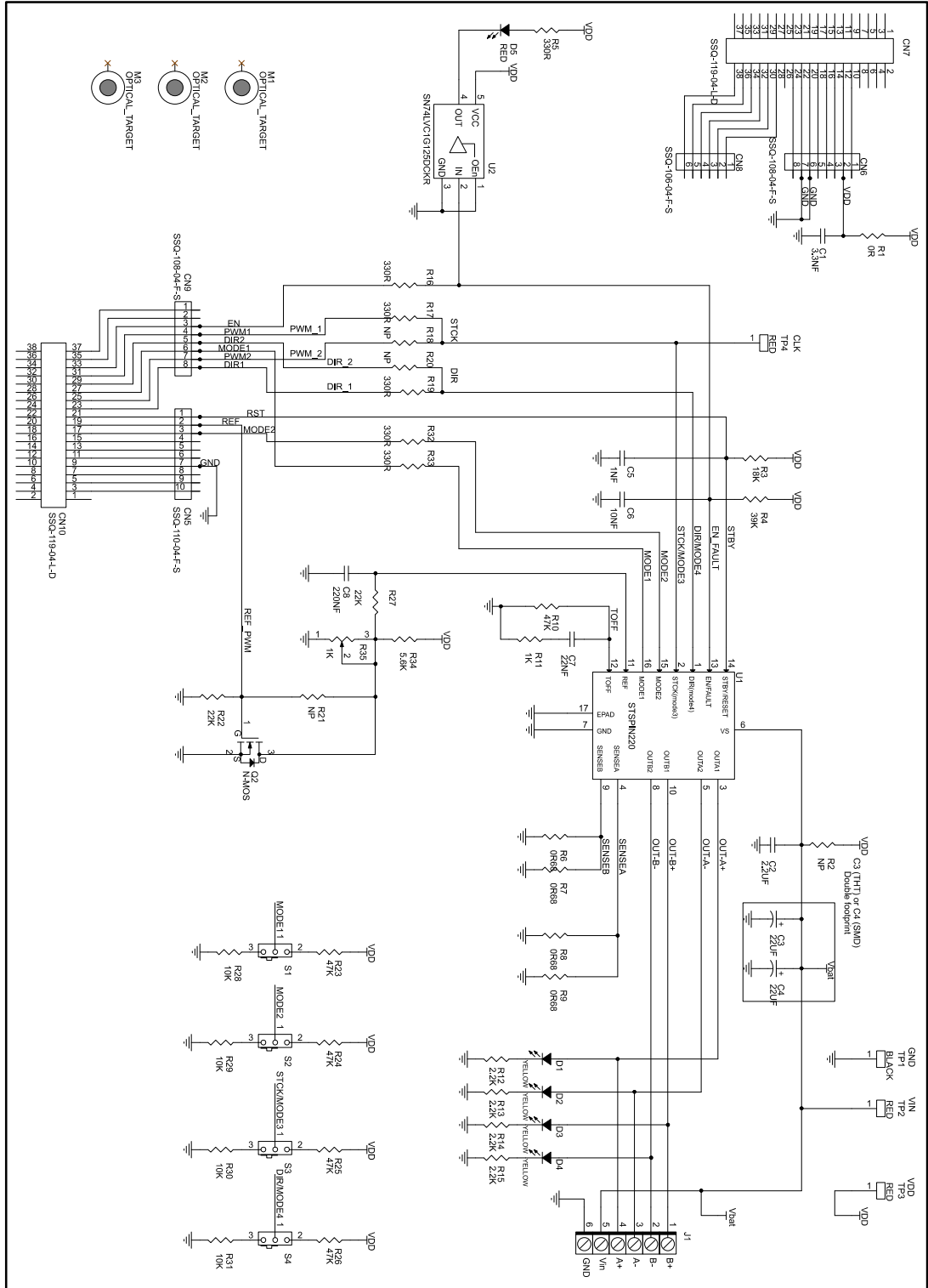

## Revision history

Table 1: Document revision history

Date	Version	Changes
23-Jun-2016	1	Initial release.

**IMPORTANT NOTICE – PLEASE READ CAREFULLY**

STMicroelectronics NV and its subsidiaries ("ST") reserve the right to make changes, corrections, enhancements, modifications, and improvements to ST products and/or to this document at any time without notice. Purchasers should obtain the latest relevant information on ST products before placing orders. ST products are sold pursuant to ST's terms and conditions of sale in place at the time of order acknowledgement.

Purchasers are solely responsible for the choice, selection, and use of ST products and ST assumes no liability for application assistance or the design of Purchasers' products.

No license, express or implied, to any intellectual property right is granted by ST herein.

Resale of ST products with provisions different from the information set forth herein shall void any warranty granted by ST for such product.

ST and the ST logo are trademarks of ST. All other product or service names are the property of their respective owners.

Information in this document supersedes and replaces information previously supplied in any prior versions of this document.

© 2016 STMicroelectronics – All rights reserved