

THIS DRAWING IS UNPUBLISHED. RELEASED FOR PUBLICATION
 © COPYRIGHT - TE Connectivity ALL RIGHTS RESERVED.

RECESSED ACTUATOR

REVISIONS				
P	LTR	DESCRIPTION	DATE	APVD
A		INITIAL RELEASE	29MAY2017	SK AS
B		REVISED PER ECO-17-014875	17OCT2017	RK AS

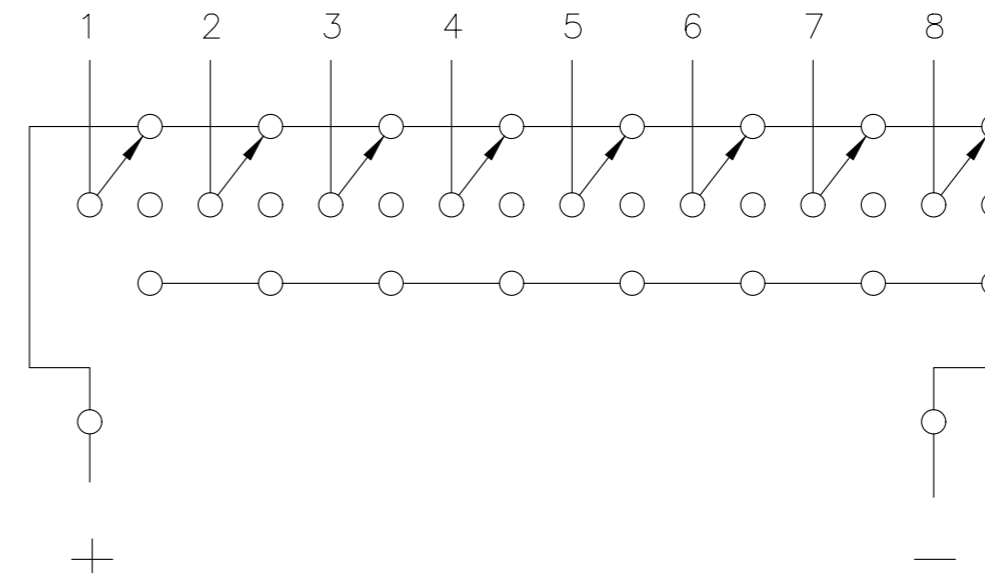
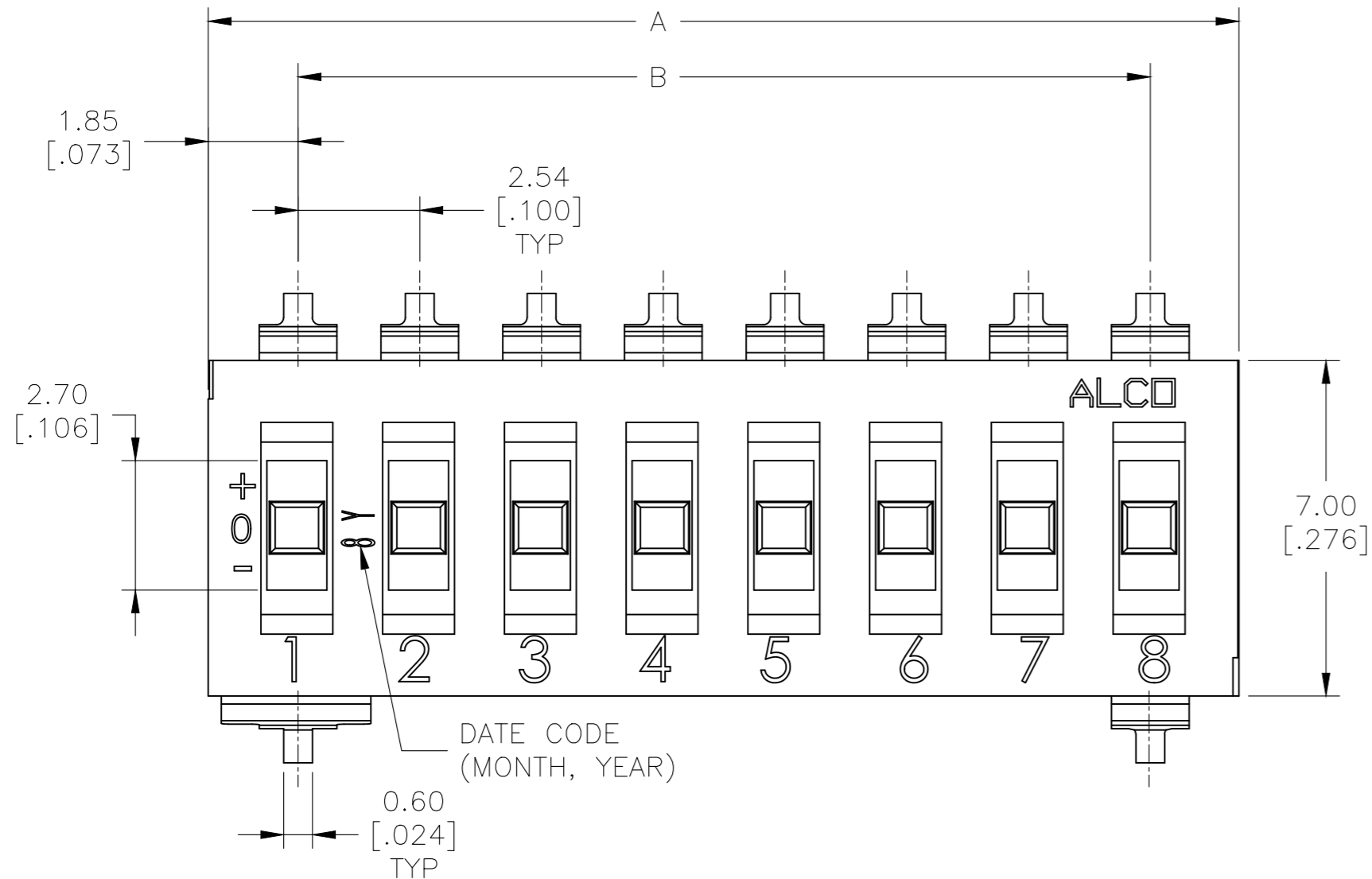

CIRCUIT DIAGRAM

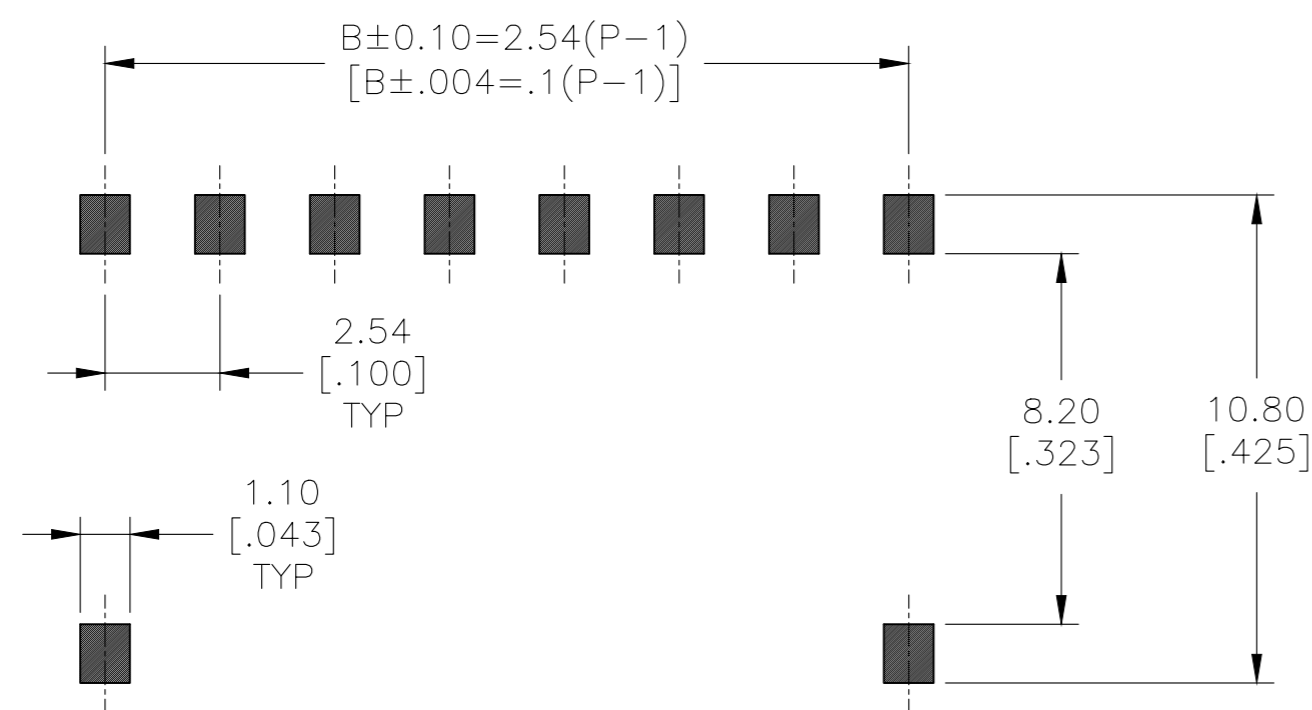
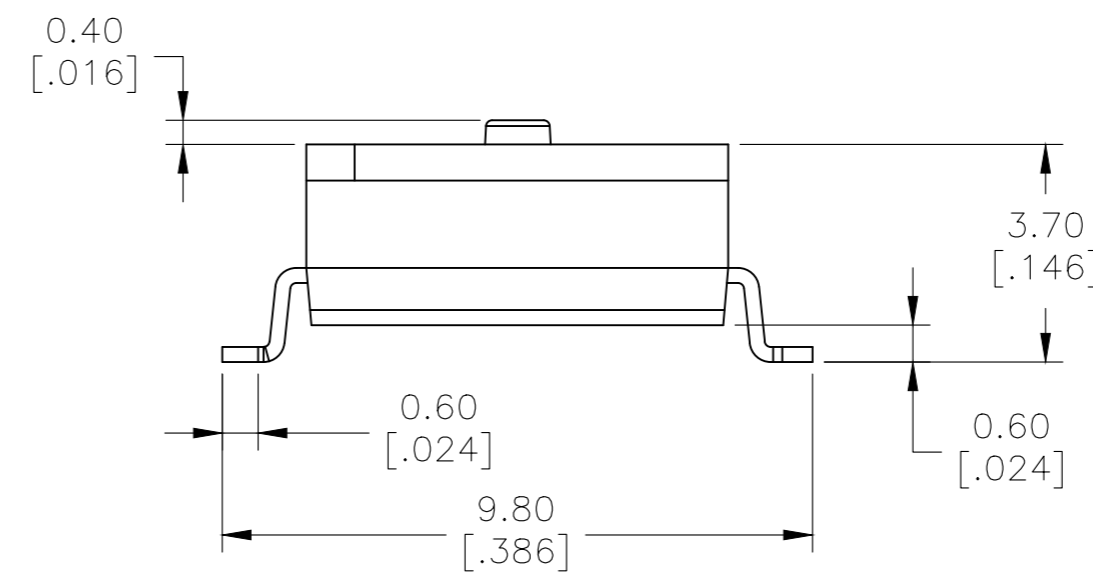
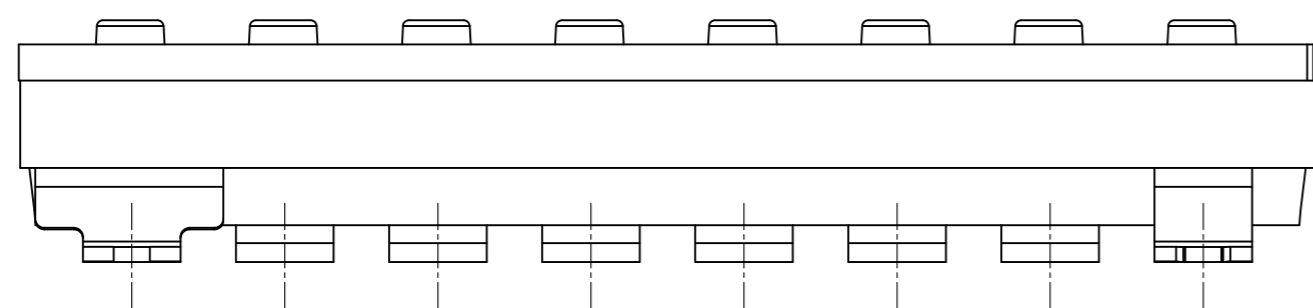

P.C.B. LAYOUT

TDS SG 04
 POSITIONS: 04,05,08,09,10
 SMT: GULL WING
 ACTUATOR: N=RAISED, R=RECESSED
 ROHS COMPLIANT
 PACKAGING: TU=TUBE, TR=TAPE AND REEL
 SEAL: N=NONE, S=TOP SEAL

THIS DRAWING IS A CONTROLLED DOCUMENT.		DWN 29MAY2017 SHIVAKUMAR S S	TE Connectivity	
DIMENSIONS: mm[INCHES]		CHK 29MAY2017 ALEXANDER SHARPE		
TOLERANCES UNLESS OTHERWISE SPECIFIED:		APVD 29MAY2017 ALEXANDER SHARPE	NAME TRI-STATE DIP SWITCHES	
0 PLC ± -	1 PLC ± -	PRODUCT SPEC	SIZE A2	CAGE CODE 00779
2 PLC ± 0.20[.008]	3 PLC ± -	APPLICATION SPEC	DRAWING NO C-2319747	RESTRICTED TO -
4 PLC ± -	ANGLES ± -	WEIGHT -	SCALE 8:1	SHEET 1 of 4
MATERIAL -	FINISH -	CUSTOMER DRAWING	REV B	

THIS DRAWING IS UNPUBLISHED. RELEASED FOR PUBLICATION
 © COPYRIGHT - TE Connectivity ALL RIGHTS RESERVED.

REVISIONS				
P	LTR	DESCRIPTION	DATE	APVD
-	-	SEE SHEET 1	-	-

RECESSED ACTUATOR

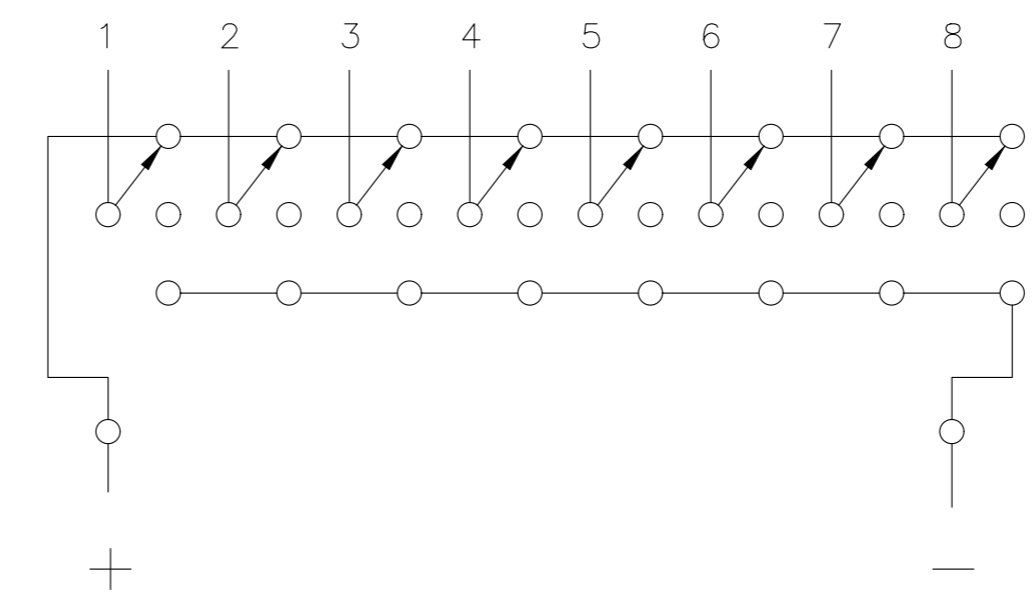
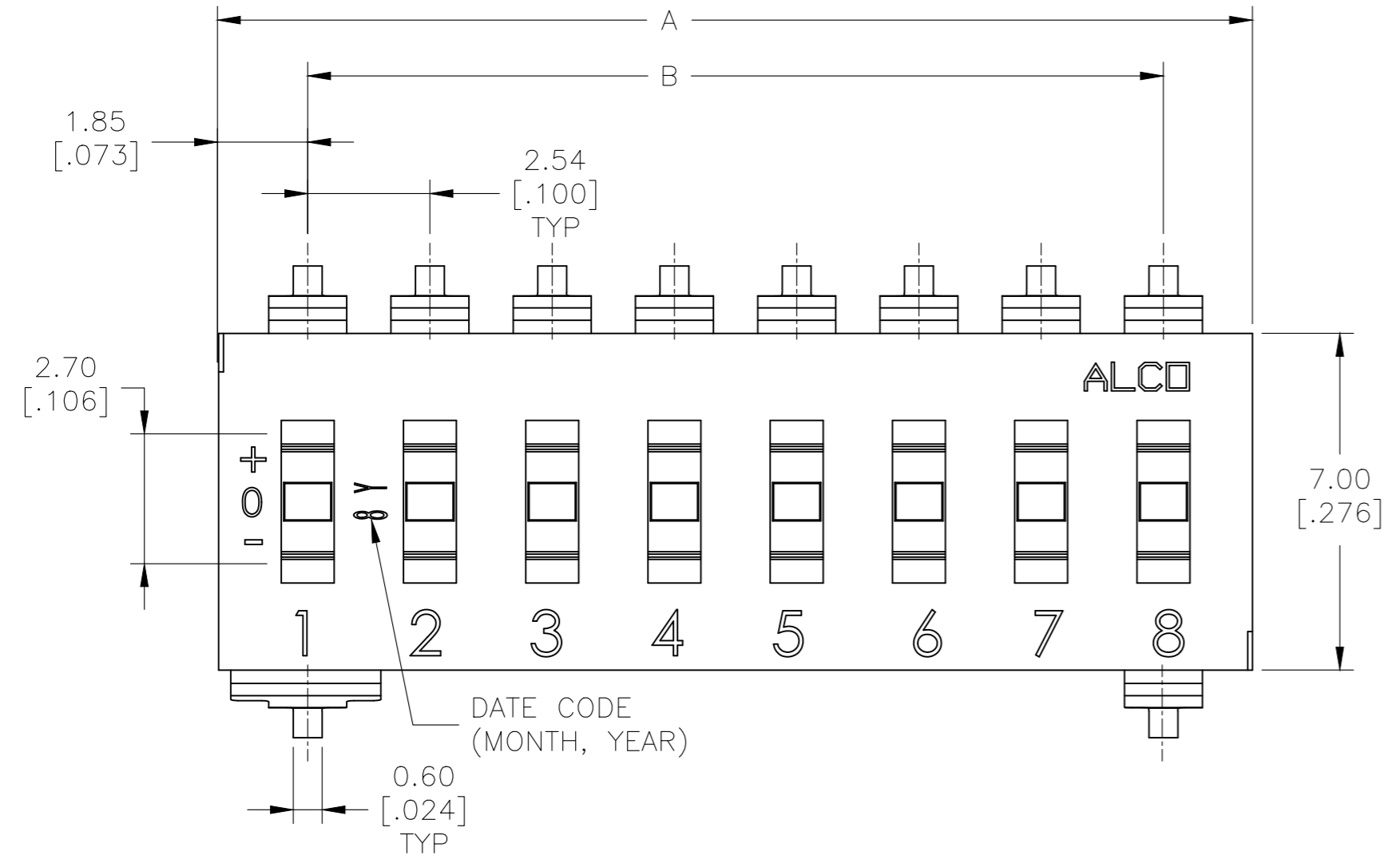

CIRCUIT DIAGRAM

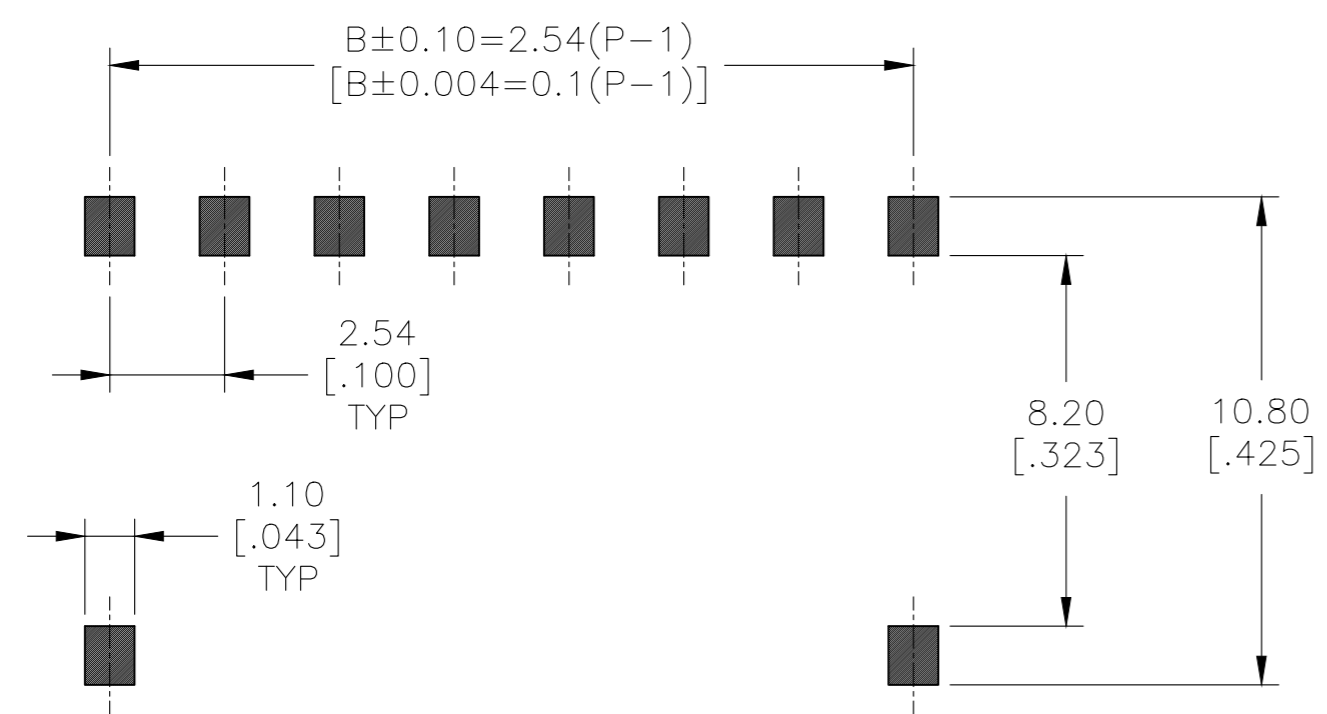
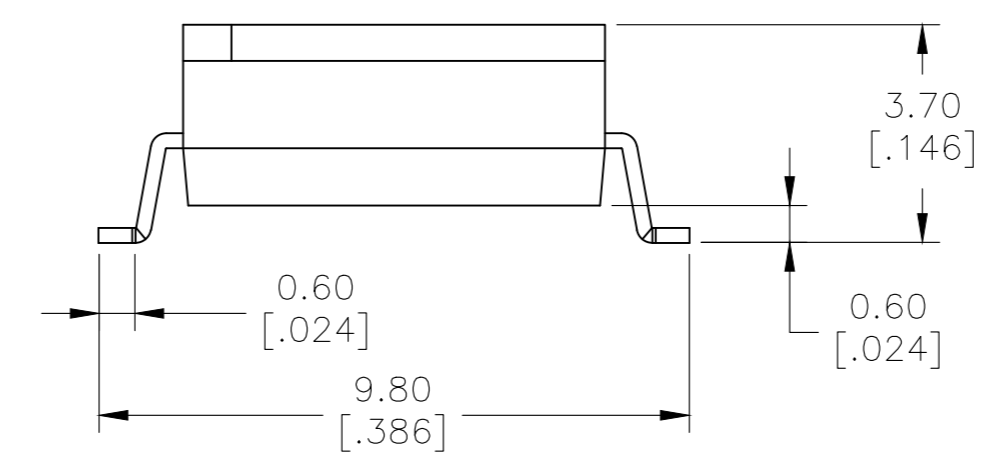
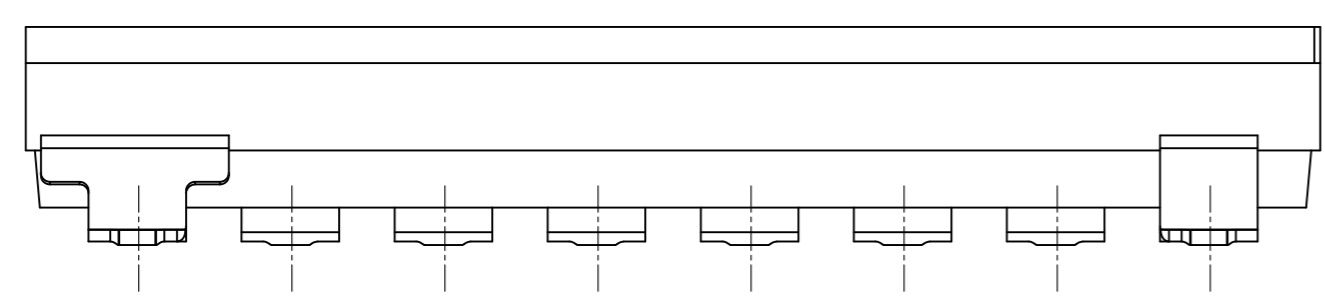

P.C.B. LAYOUT

THIS DRAWING IS A CONTROLLED DOCUMENT.		DWN 29MAY2017 SHIVAKUMAR S S	TE Connectivity	
DIMENSIONS: mm[INCHES]		CHK 29MAY2017 ALEXANDER SHARPE		
TOLERANCES UNLESS OTHERWISE SPECIFIED:		APVD 29MAY2017 ALEXANDER SHARPE	PRODUCT SPEC -	SIZE A2
0 PLC ± - 1 PLC ± - 2 PLC ± 0.20[.008] 3 PLC ± - 4 PLC ± - ANGLES ± -		APPLICATION SPEC -	RESTRICTED TO -	CAGE CODE 00779
MATERIAL -		FINISH -	WEIGHT -	DRAWING NO C-2319747
CUSTOMER DRAWING			SCALE 8:1	SHEET 2 of 4

THIS DRAWING IS UNPUBLISHED. RELEASED FOR PUBLICATION
 © COPYRIGHT - TE Connectivity ALL RIGHTS RESERVED.

REVISIONS				
P	LTR	DESCRIPTION	DATE	APVD
-	-	SEE SHEET 1	-	-

TOP TAPE SEAL	ACTUATOR	NOTE	B	A	No OF POSITION	TE DESCRIPTIVE PART NUMBER	TE PART NUMBER
			DIM				
YES	RECESSED	△3	22.86 [.900]	26.56 [1.046]	10	TDS10SGRSTR04	3-2319747-0
			20.32 [.800]	24.02 [.946]	9	TDS09SGRSTR04	2-2319747-9
			17.78 [.700]	21.48 [.846]	8	TDS08SGRSTR04	2-2319747-8
			10.16 [.400]	13.86 [.546]	5	TDS05SGRSTR04	2-2319747-7
			7.62 [.300]	11.32 [.446]	4	TDS04SGRSTR04	2-2319747-6
NO	RAISED	△3	22.86 [.900]	26.56 [1.046]	10	TDS10SGRNTR04	2-2319747-5
			20.32 [.800]	24.02 [.946]	9	TDS09SGRNTR04	2-2319747-4
			17.78 [.700]	21.48 [.846]	8	TDS08SGRNTR04	2-2319747-3
			10.16 [.400]	13.86 [.546]	5	TDS05SGRNTR04	2-2319747-2
			7.62 [.300]	11.32 [.446]	4	TDS04SGRNTR04	2-2319747-1
			22.86 [.900]	26.56 [1.046]	10	TDS10SGNTR04	2-2319747-0
			20.32 [.800]	24.02 [.946]	9	TDS09SGNTR04	1-2319747-9
			17.78 [.700]	21.48 [.846]	8	TDS08SGNTR04	1-2319747-8
10.16 [.400]	13.86 [.546]	5	TDS05SGNTR04	1-2319747-7			
7.62 [.300]	11.32 [.446]	4	TDS04SGNTR04	1-2319747-6			

TOP TAPE SEAL	ACTUATOR	NOTE	B	A	No OF POSITION	TE DESCRIPTIVE PART NUMBER	TE PART NUMBER
			DIM				
YES	RECESSED	△2	22.86 [.900]	26.56 [1.046]	10	TDS10SGRSTU04	1-2319747-5
			20.32 [.800]	24.02 [.946]	9	TDS09SGRSTU04	1-2319747-4
			17.78 [.700]	21.48 [.846]	8	TDS08SGRSTU04	1-2319747-3
			10.16 [.400]	13.86 [.546]	5	TDS05SGRSTU04	1-2319747-2
			7.62 [.300]	11.32 [.446]	4	TDS04SGRSTU04	1-2319747-1
NO	RAISED	△2	22.86 [.900]	26.56 [1.046]	10	TDS10SGRNTR04	1-2319747-0
			20.32 [.800]	24.02 [.946]	9	TDS09SGRNTR04	2319747-9
			17.78 [.700]	21.48 [.846]	8	TDS08SGRNTR04	2319747-8
			10.16 [.400]	13.86 [.546]	5	TDS05SGRNTR04	2319747-7
			7.62 [.300]	11.32 [.446]	4	TDS04SGRNTR04	2319747-6
			22.86 [.900]	26.56 [1.046]	10	TDS10SGNTR04	2319747-5
			20.32 [.800]	24.02 [.946]	9	TDS09SGNTR04	2319747-4
			17.78 [.700]	21.48 [.846]	8	TDS08SGNTR04	2319747-3
10.16 [.400]	13.86 [.546]	5	TDS05SGNTR04	2319747-2			
7.62 [.300]	11.32 [.446]	4	TDS04SGNTR04	2319747-1			

THIS DRAWING IS A CONTROLLED DOCUMENT.		DWN SHIVAKUMAR S S 29MAY2017	 TE Connectivity	
DIMENSIONS: mm[INCHES]		CHK ALEXANDER SHARPE 29MAY2017		
TOLERANCES UNLESS OTHERWISE SPECIFIED:		APVD ALEXANDER SHARPE 29MAY2017	NAME TRI-STATE DIP SWITCHES	
0 PLC ± - 1 PLC ± - 2 PLC ± 0.20[.008] 3 PLC ± - 4 PLC ± - ANGLES ± -		PRODUCT SPEC -	RESTRICTED TO -	
MATERIAL		FINISH	SIZE A2	CAGE CODE 00779
		WEIGHT	DRAWING NO C-2319747	
		CUSTOMER DRAWING	SCALE 8:1	SHEET 3 of 4

REVISIONS				
P	LTR	DESCRIPTION	DATE	APVD
-	-	SEE SHEET 1	-	-

SOLDERING CONDITIONS:

THE CONDITIONS MENTIONED BELOW IS THE TEMPERATURE ON THE CU FOIL OF THE P.C.B SURFACE. DO NOT ALLOW THE SWITCH'S SURFACE TEMPERATURE TO EXCEED 260°C.

MANUAL SOLDERING

SOLDERING TEMPERATURE	MAX. 350°C.
CONTINUOUS SOLDERING TIME	MAX. 5 SECONDS.

REFLOW SOLDERING

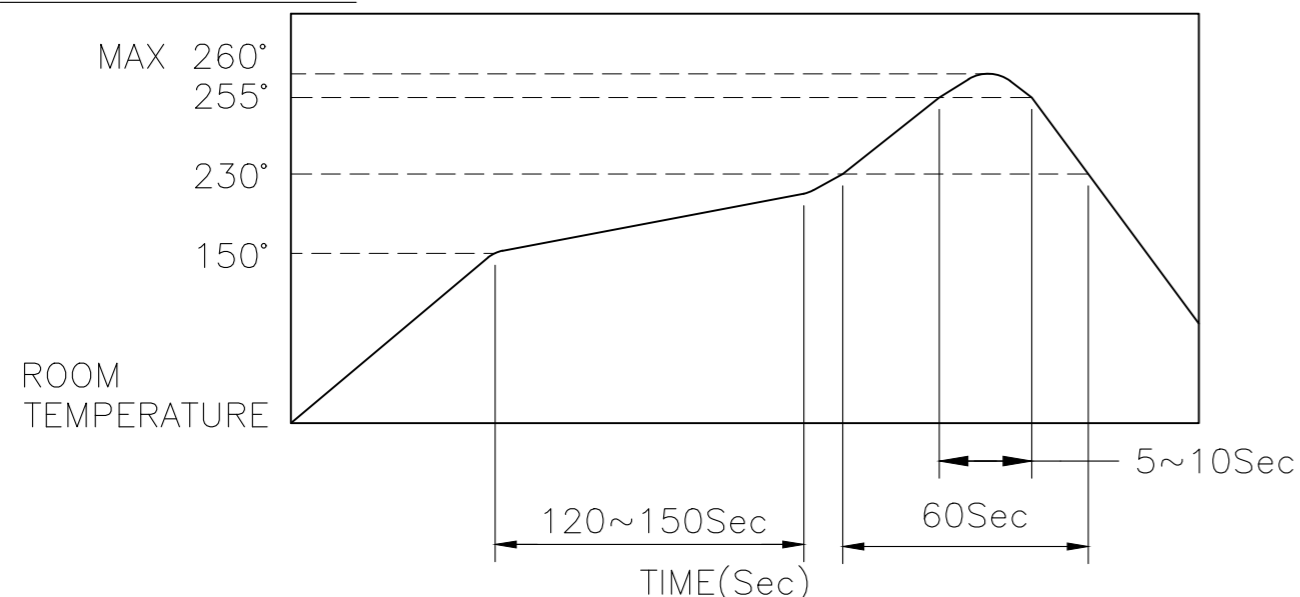

HANDLING PRECAUTIONS

- CARE SHOULD BE EXERCISED SO THAT FLUX FROM THE UPPER PART OF THE PRINTED CIRCUIT BOARD DOES NOT ADHERE TO THE SWITCH.
- DON'T CLEAN THE SWITCH BODY EXCEPT WITH TOP TAPE SEALED TYPE, WHICH CAN ONLY SPRAY OF CLEANING METHOD FROM TOP OF S/W.
- ENSURE FLUX DOES NOT RISE ABOVE THE TOP SURFACE OF THE PCB.

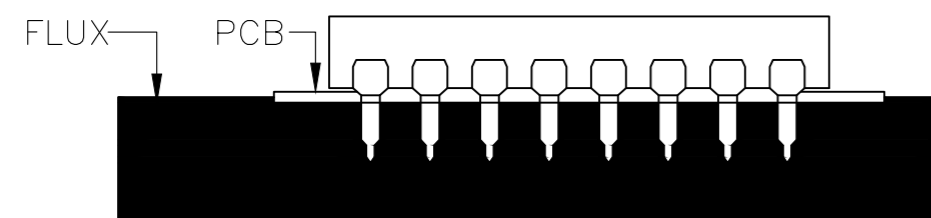

SPECIFICATIONS:

MATERIALS:

BASE: PA (HIGH-TEMP. NYLON) UL94V-0
 COVER: PA (HIGH-TEMP. NYLON) UL94V-0
 ACTUATOR: LCP UL94V-0
 CONTACT: COPPER ALLOY, GOLD (in contact area)
 OVER NICKEL PLATE
 TERMINAL: BRASS ALLOY, GOLD PLATE
 TAPE: POLYAMIDE.

ELECTRICAL:

CONTACT RATING: NON-SWITCHING 100mA @ 50 VDC.
 SWITCHING: 25mA @ 24 VDC.
 INITIAL CONTACT RESISTANCE: 100mΩ MAX. @ 2 VDC. 10mA.
 INSULATION RESISTANCE: 100 MEGOHMS MIN. @ 500 VDC,
 1 MINUTE +/- 5 SECONDS.
 DIELECTRIC STRENGTH: 500 VAC (50 OR 60 HZ), 1 MINUTE.
 DURABILITY: 2,000 CYCLES.
 CAPACITANCE: 5 pF MAX @ 1 MHz +/- 10 KHz.

MECHANICAL:

OPERATING FORCE: 1000gf MAX.

ENVIRONMENTAL:

OPERATING TEMPERATURE: -20°C TO +85°C.
 STORAGE TEMPERATURE: -40°C TO +85°C.
 SOLDER HEAT RESISTANCE PER 109-201, CONDITION B.
 SOLDERABILITY PER JIS C 0050 & JIS C 0053.

NOTES:

1 ALL MATERIALS AND FINISHES SHALL COMPLY WITH EU DIRECTIVE 2002/95/EC OF 27 JAN 2003 (ROHS).



TUBE PACKAGING.



TAPE AND REEL PACKAGING.

THIS DRAWING IS A CONTROLLED DOCUMENT.		DWN 29MAY2017 SHIVAKUMAR S S	TE Connectivity																					
DIMENSIONS: mm [INCHES]		CHK 29MAY2017 ALEXANDER SHARPE			NAME TRI-STATE DIP SWITCHES																			
TOLERANCES UNLESS OTHERWISE SPECIFIED:		APVD 29MAY2017 ALEXANDER SHARPE	PRODUCT SPEC	RESTRICTED TO																				
<table border="1"> <tr><td>0 PLC</td><td>±</td><td>-</td></tr> <tr><td>1 PLC</td><td>±</td><td>-</td></tr> <tr><td>2 PLC</td><td>±</td><td>0.20[.008]</td></tr> <tr><td>3 PLC</td><td>±</td><td>-</td></tr> <tr><td>4 PLC</td><td>±</td><td>-</td></tr> <tr><td>ANGLES</td><td>±</td><td>-</td></tr> </table>		0 PLC	±	-	1 PLC	±	-	2 PLC	±	0.20[.008]	3 PLC	±	-	4 PLC	±	-	ANGLES	±	-	APPLICATION SPEC	SIZE	CAGE CODE	DRAWING NO	RESTRICTED TO
0 PLC	±	-																						
1 PLC	±	-																						
2 PLC	±	0.20[.008]																						
3 PLC	±	-																						
4 PLC	±	-																						
ANGLES	±	-																						
MATERIAL		FINISH	WEIGHT	A2	00779	C=2319747	-																	
			CUSTOMER DRAWING	SCALE	8:1	SHEET	4 OF 4																	
						REV	B																	