

PART NUMBER	REV	FIRST USED	LEADMAKER	MECH POST FEED
466856-1	G	854400-1	LEADMAKER	MECH POST FEED
466856-2	G	565435-5	BENCH MODEL K	MECH PRE FEED
466856-3	H	565435-5	BENCH MODEL K	MECH PRE FEED
466856-4	G	354500-1	BENCH MODEL G	MECH PRE FEED

FOR -1, -2 & -4
TYPE I TERMINAL TYPE II TERMINAL

TERMINAL NAME: MAG MATE POKE-IN-TAB	
TYPE I	TYPE II
STK THK .020	STK THK .018
62897	62895
63410	

CRIMPING DATA			
PAD LTR	CRIMP HEIGHT	WIRE SIZE	
A	.062 ±.002	18	
B	.058 ±.002	20	
C	.054 ±.002	22	
D	NOT	USED	
CRIMP	SIZE	TYPE	RANGE
WIRE	.090	F	22-18
INSUL	-	-	-
FEED	APPL INST	SET UP GAGE	LAYOUT
.360	408-8040	458637-1	889
WIRE STRIP LENGTH .156-.187			

CRIMPING DATA			
PAD LTR	CRIMP HEIGHT	WIRE SIZE	
A	NOT	USED	
B	.058 ±.002	18	
C	.054 ±.002	20	
D	.051 ±.002	22	
CRIMP	SIZE	TYPE	RANGE
WIRE	.090	F	22-18
INSUL	-	-	-
FEED	APPL INST	SET UP GAGE	LAYOUT
.360	408-8040	458637-1	889
WIRE STRIP LENGTH .156-.187			

FOR -3
TYPE I TERMINAL TYPE II TERMINAL

CRIMPING DATA			
PAD LTR	CRIMP HEIGHT	WIRE SIZE	
A	.056 ±.002	18	
B	.052 ±.002	20	
C	.050 ±.002	22	
D	NOT	USED	
CRIMP	SIZE	TYPE	RANGE
WIRE	.100	F	22-18
INSUL	-	-	-
FEED	APPL INST	SET UP GAGE	LAYOUT
.360	408-8040	458637-1	889
WIRE STRIP LENGTH .156-.187			

CRIMPING DATA			
PAD LTR	CRIMP HEIGHT	WIRE SIZE	
A	NOT	USED	
B	.052 ±.002	18	
C	.050 ±.002	20	
D	.046 ±.002	22	
CRIMP	SIZE	TYPE	RANGE
WIRE	.100	F	22-18
INSUL	-	-	-
FEED	APPL INST	SET UP GAGE	LAYOUT
.360	408-8040	458637-1	889
WIRE STRIP LENGTH .156-.187			

- 1 RECOMMENDED SPARE PARTS.
- 2 GREASE LIGHTLY.
- 3 GUARD MUST BE IN PLACE WHEN OPERATING APPLICATOR IN A BENCH MACHINE.
- 4 LUBRICATE DAILY USING NO. 20 MACHINE OIL.
5. ITEMS WITH QTY OF REF SPECIFIED (EXCEPT ITEMS 78 AND 79) ARE USED ON ITEM 46.
- 6 REMOVE ITEMS 50 & 51 WHEN APPLYING TERMINALS 62895 OR 63410.
- 7 READJUSTMENT OF REAR STRIP GUIDE IS REQUIRED WHEN CHANGING FROM STRAIGHT TO BENT TABS.

-	2	-	-	-	C	6-354779-0	PIN, WIRE DISC (.3290)D	134	
-	2	-	-	-	C	5-354779-3	PIN, WIRE DISC (.3255)C	133	
-	2	-	-	-	C	4-354779-8	PIN, WIRE DISC (.3230)B	132	
-	2	-	-	-	C	4-354779-0	PIN, WIRE DISC (.3190)A	131	
								130	
2	-	2	2	-	C	2-354779-0	PIN, WIRE DISC (.3090)D	129	
2	-	2	2	-	C	1-354779-4	PIN, WIRE DISC (.3060)C	128	
2	-	2	2	-	C	354779-6	PIN, WIRE DISC (.3020)B	127	
2	-	2	2	-	C	9-354778-7	PIN, WIRE DISC (.2980)A	126	
1	1	1	1	-	A	986950-1	WASHER, FLAT PRECISION	125	
REF	REF	REF	REF	-	A	21045-3	RING, RET "C" (Ø.187)FD FING PIN	124	
								123	
REF	REF	REF	REF	-	A	5-21028-1	PIN, SLT SPR (Ø.125x.50)ADJ ROD	122	
1	1	1	1	-	A	4-21028-0	PIN, SLT SPR (Ø.093x.75)ST GDE PL	121	
REF	REF	REF	REF	-	A	1-21030-1	PIN, DOWEL (Ø.187x.50)LEVER	120	
REF	REF	REF	REF	-	A	1-21030-6	PIN, DOWEL (Ø.187x1.25)HOUSING	-	
								118	
1	1	1	1	-	A	21024-5	WASHER, LOCK (#10)ADJ BLOCK	117	
REF	REF	REF	REF	-	A	21024-5	WASHER, LOCK (#10)ADJ PLATE	116	
REF	REF	REF	REF	-	A	21024-5	WASHER, LOCK (#10)FEED GDE ROD	115	
2	2	2	2	-	A	21024-2	WASHER, LOCK (#4)FRONT STP GUIDE	114	
								113	
								112	
4	4	4	4	-	A	21024-4	WASHER, LOCK (#8)STRIPPER	111	
REF	REF	REF	REF	-	A	21899-4	WASHER, FLAT (Ø5/16) SCREW ADJ	110	
								109	
1	1	1	1	-	A	21018-5	NUT, HEX (NO. 6)HOLDDOWN	108	
REF	REF	REF	REF	-	A	21018-5	NUT, HEX (6-32)FEED ADJ	107	
								106	
								105	
								104	
1	1	1	1	-	A	21009-2	SCR, 5KT 5ET (1/4-20x.25 LW)RAM	103	
2	2	2	2	-	A	21017-2	SCR, DRIVE (#2x.19)ID PLATE	102	
REF	REF	REF	REF	-	A	6-23715-5	SCR, PAN HD (6-32x1.50)FEED ADJ	101	
1	1	1	1	-	B	461264-1	PLATE, IDENTIFICATION	100	
2	2	2	2	-	A	3-21002-0	SCR, BHC (10-32x.88)DRAG	99	
1	1	1	1	-	A	22733-8	SCR, BHC (8-32x.38 LW)ANVIL	98	
REF	REF	REF	REF	-	A	2-21002-9	SCR, BHC (10-32x.75)CAP	97	
REF	REF	REF	REF	-	A	2-22733-8	SCR, BHC (1/4-20x.62)HOUSING	96	
REF	REF	REF	REF	-	A	2-21002-7	SCR, BHC (10-32x.50)56 ADJ BLOCK	95	
4	4	4	4	-	A	2-21002-2	SCR, BHC (8-32x.50)SHEAR	94	
								93	
								92	
1	1	1	1	-	A	1-21002-7	SCR, BHC (6-32x.38)CAM	91	
								90	
								89	
								88	
								87	
1	1	1	1	-	A	2-22603-0	SCR, HEX HD (8-32x.31)FEED FINGER	86	
2	2	2	2	-	A	1-21000-3	SCR, SHC (4-40x.25)F ST GUIDE	85	
3	3	3	3	-	A	2-21000-7	SCR, SHC (8-32x.50)STRIPPER	84	
REF	REF	REF	REF	-	A	3-21000-7	SCR, SHC (10-32x.75)FEED ROD GD	83	
REF	REF	REF	REF	-	A	3-21000-6	SCR, SHC (10-32x.62)FD ADJ BLK	82	
1	1	1	1	-	A	3-21000-4	SCR, SHC (10-32x.38)56 ADJ BL	81	
REF	REF	REF	REF	-	A	3-21000-4	SCR, SHC (10-32x.38)PIVOT BLK	80	
-	1	1	-	-	B	455755-3	GUARD ASSY	79	
REF	-	-	-	-	B	679532-1	INSERT, GUARD	78	
								77	
								76	
								75	
								74	
								73	
REF	REF	REF	REF	-	A	458109-1	WASHER, SPECIAL	72	
REF	REF	REF	REF	-	A	690517-1	SPACER	71	
								70	
QTY	REF	REF	REF	REF	U/M	DWG SIZE	PART NO	DESCRIPTION	ITEM NO
	-4	-3	-2	-1					
REVISION OF EACH ASSY NO (WHEN BLANK, USE DWG REVISION)									
QTY REOD PER ASSY					PARTS LIST				

REF	REF	REF	REF	-	B	22594-8	NUT, HEX (1/2-20)	70	
REF	REF	REF	REF	-	B	240628-1	PLATE, ADJUSTMENT	69	
REF	REF	REF	REF	-	B	240626-1	SHAFT, PIVOT	68	
REF	REF	REF	REF	-	B	240633-1	BUSHING	67	
REF	REF	REF	REF	-	A	455680-1	LEVER, INTERMEDIATE	66	
REF	REF	REF	REF	-	B	240629-1	BLOCK, PIVOT	65	
REF	REF	REF	REF	-	A	240632-2	SCREW, ADJ FEED ROD	64	
REF	REF	REF	REF	-	B	240659-3	PIN, CAM ROLLER	63	
REF	REF	REF	REF	-	B	240658-1	ROLLER, CAM	62	
REF	REF	REF	REF	-	B	454398-2	ROD, FEED	61	
REF	REF	REF	REF	-	A	454178-1	GUIDE, FEED ROD	60	
REF	REF	REF	REF	-	C	454220-1	CAP, RAM	59	
REF	REF	REF	REF	-	D	454485-1	HOUSING	58	
								57	
1	1	1	1	-	B	458537-1	PAWL, FEED	56	
REF	REF	REF	REF	-	B	240624-1	PIN, FEED FINGER	55	
REF	REF	REF	REF	-	B	691499-1	SPRING, FEED FINGER	54	
REF	REF	REF	REF	-	B	690541-1	HOLDER, FEED FINGER	53	
REF	REF	REF	REF	-	A	455679-2	LEVER, TERMINAL FEED ARM	52	
1	1	1	1	-	A	811242-2	BUMPER, HOLDDOWN	51	
1	1	1	1	-	A	690753-1	SPACER, TONKER	50	
1	-	-	-	-	B	690602-6	CAM, PRE-FEED 1 5/8 ST	49	
-	1	1	-	-	B	690602-5	CAM, PRE-FEED 1 1/8 ST	48	
-	-	-	-	-	B	690501-4	CAM, POST-FEED 1 5/8 ST	47	
1	1	1	1	-	B	459456-2	APPLICATOR, BASIC (SUBASSY)	46	
1	1	1	1	-	A	690191-1	PLUG, NYLON	45	
1	1	1	1	-	C	455673-1	RAM	44	
1	1	1	1	-	A	690125-1	WASHER, LAMINATED	43	
1	1	1	1	-	A	690124-3	WASHER, RAM	42	
1	1	1	1	-	A	7-21002-9	BOLT, CRIMPER (5/16x1.00)	41	
								40	
								39	
1	1	1	1	-	A	690223-2	SPACER, INSULATION DISC	38	
1	1	1	1	-	D	354777-1	WIRE DISC, PLASTIC	37	
1	1	1	1	-	A	22480-5	WASHER, SPRING	36	
1	1	1	1	-	B	690212-1	POST, RAM	35	
								34	
REF	REF	REF	REF	-	D	455675-1	PLATE, BASE	33	
1	1	1	1	-	A	690432-3	SCREW, ADJUSTMENT	32	
								31	
REF	REF	REF	REF	-	B	455689-1	BLOCK, STRIP GUIDE ADJ	30	
1	1	1	1	-	C	455671-1	PLATE, STRIP GUIDE	29	
1	1	1	1	-	C	1-455888-0	SPACER, FRONT SHEAR DEP	28	
2	2	2	2	-	A	1-22284-0	SPRING, DRAG	27	
1	1	1	1	-	B	690546-1	LEVER, DRAG RELEASE	26	
1	1	1	1	-	B	240792-1	DRAG, TERMINAL	25	
1	1	1	1	-	D	5-690440-9	GUIDE, STRIP (REAR)	24	
1	1	1	1	-	A	690438-1	GUIDE, STRIP (FRONT)	23	
-	-	-	-	-	B	690472-6	STRIPPER	22	
REF	REF	REF	REF	-	A	4-22284-9	SPRING, FEED RETURN	21	
								20	
1	1	1	-	-	B	683369-1	STRIPPER	19	
								18	
								17	
1	1	1	1	-	A	691667-1	GUARD, CHIP (FRONT)	16	
								15	
								14	
								13	
1	1	1	1	-	A	5-22280-0	SPRING, SHEAR	12	
1	1	1	1	-	B	690461-1	STOP, SHEAR	11	
1	1	1	1	-	C	690459-1	HOLDER, SHEAR (FRONT)	10	
1	1	1	1	-	C	454276-1	SHEAR, FLOAT (FRONT)	9	
1	-	-	-	-	C	4-690512-8	ANVIL	8	
-	1	-	-	-	C	2-683403-8	ANVIL	7	
-	1	-	-	-	C	1-455889-4	DEPRESSOR, SHEAR (FRONT)	6	
1	-	-	-	-	C	455889-9	DEPRESSOR, SHEAR (FRONT)	5	
								4	
								3	
-	1	-	-	-	C	1-456407-4	CRIMPER, WIRE	2	
1	-	-	-	-	C	3-456406-0	CRIMPER, WIRE	1	
QTY	REF	REF	REF	REF	U/M	DWG SIZE	PART NO	DESCRIPTION	ITEM NO
	-4	-3	-2	-					

THIS DRAWING IS A CONTROLLED DOCUMENT.

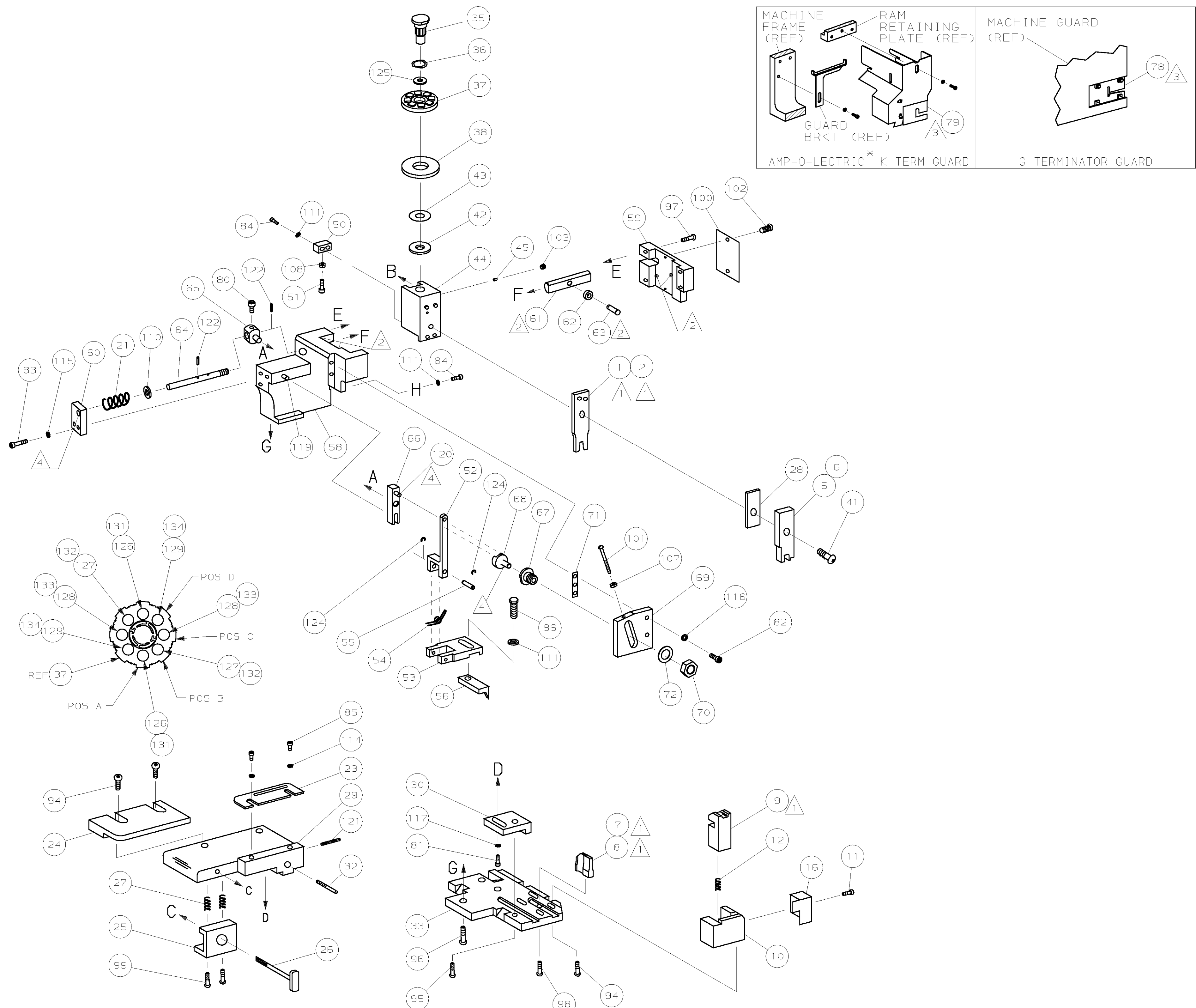

THIS DRAWING IS UNCLASSIFIED
 DATE 12/15/00 BY 27262/2000
 RELEASED FOR PUBLICATION
 BY AMP INCORPORATED. ALL RIGHTS RESERVED.

* Trademark of AMP Incorporated

<p>POST FEED 1 5/8 STROKE</p> <p>ROTATED 180° B</p> <p>T TERMINATING UNIT</p>	<p>PRE FEED 1 1/8 STROKE</p> <p>ROTATED 180° B</p> <p>K TERMINATING UNIT</p>	<p>PRE FEED 1 5/8 STROKE</p> <p>ROTATED 180° B</p> <p>G TERMINATING UNIT</p>
<p>LEADMAKER</p>	<p>BENCH MACHINE</p>	

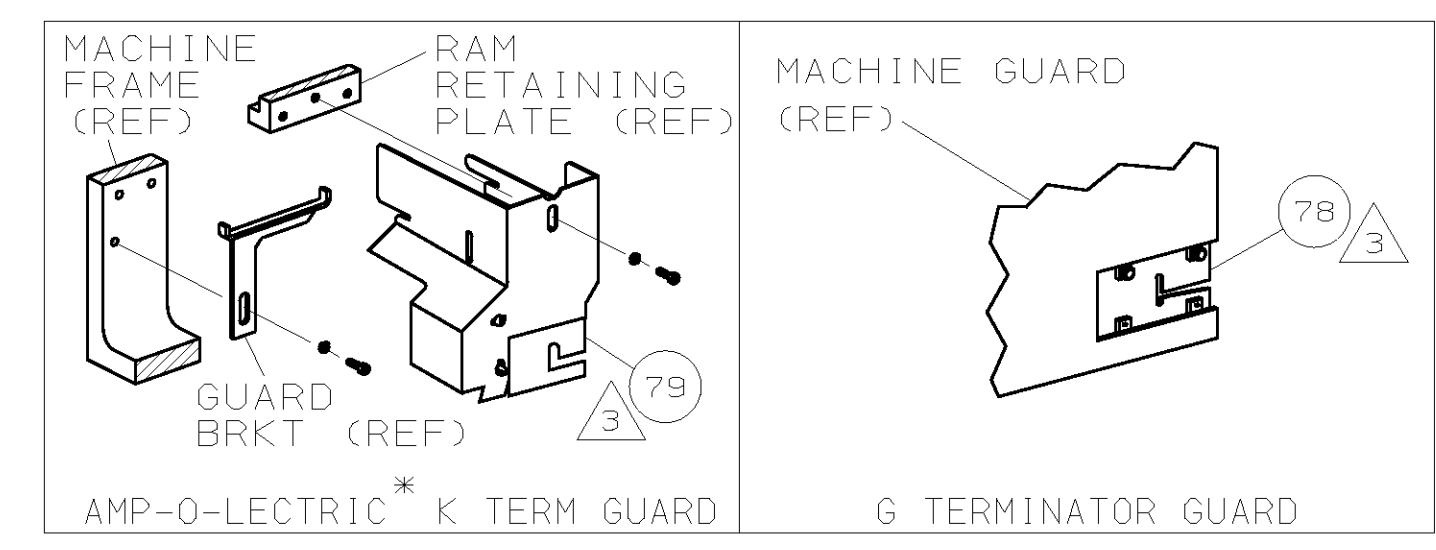

SEE SHEET 1

P	F	L	T	R	REVISION RECORD	APP	DATE

QTY	REQD PER ASSY	PART NO	DESCRIPTION	ITEM NO
REVISION OF EACH ASSY NO (WHEN BLANK, USE DWG REVISION)				
PARTS LIST				
DIMENSIONS IN INCHES. DO NOT SCALE PRINT. TOLERANCES UNLESS OTHERWISE SPECIFIED:		MATL	HT TR	FIN
2 PLC DEC ± -				
3 PLC DEC ± -				
4 PLC DEC ± -				
ANGLES ± -				
SURF TEXTURE: ✓				
REMOVE BURRS, BREAK SHARP EDGES R.015 MAX				
SCALE	DWG NO	466856		SHEET 2 OF 2
NAME		SIDE FEED HDM APPLICATOR		MACHINE REF MINI APPL
DR		4/7/94 APP 4-7-94		
CHK		D.SALTZER E.KOOTTE		
REL		5/16/94 B. MORGAN		
C.ERISMAN				
AMP		AMP Incorporated		
Harrisburg, PA 17105-3608				
CASE CODE 00779		CUSTOMER AND ASSEMBLY DRAWING 1		RESTRICTED TO