

REVISIONS					
REV	ECO	DESCRIPTION	DATE	BY	APPR
B1	-	RELEASED DRAWING	JULY-1-2014	BEN	TOMMY

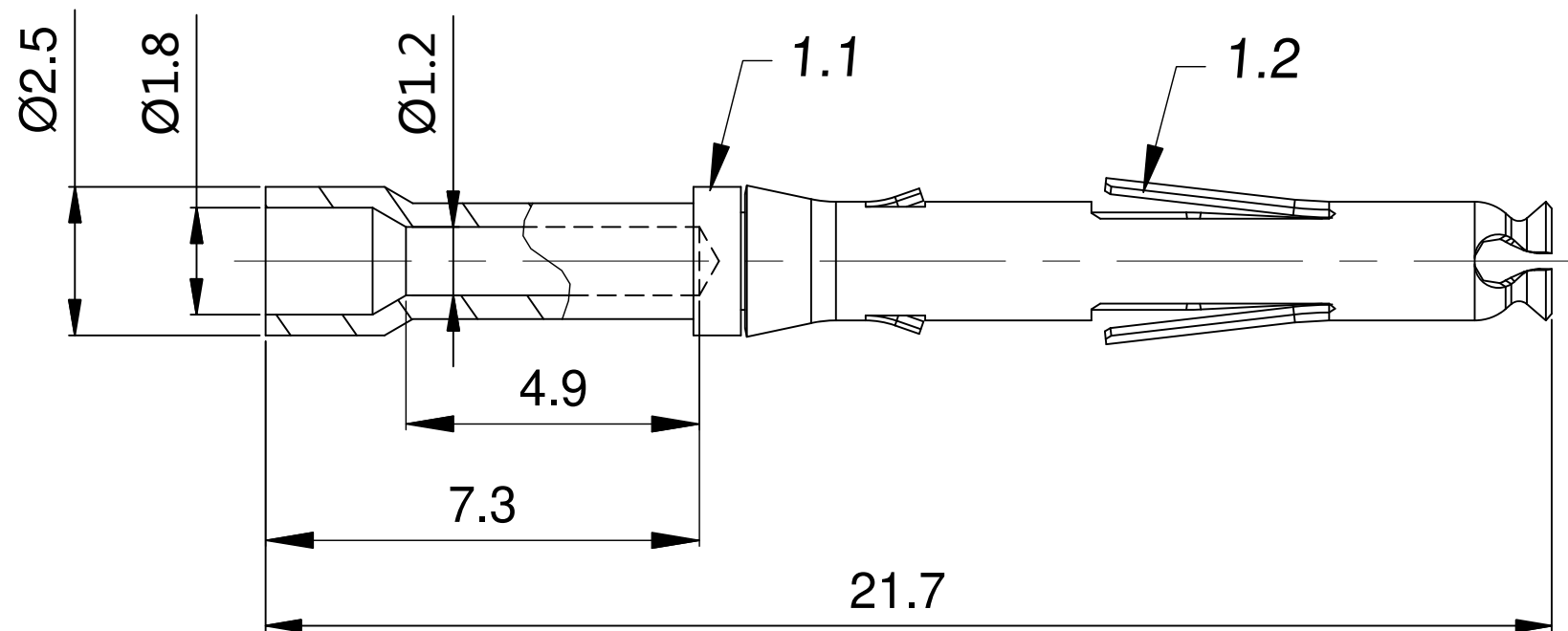

NOTES : (UNLESS OTHERWISE SPECIFIED)

1. MATERIAL :
 - 1.1. CONTACT BODY : COPPER ALLOY.
 - 1.2. POSITIONING CLIP : STAINLESS STEEL.
2. SPECIFICATIONS :
 - 2.1 CURRENT RATING : 7.5A(MAX).
 - 2.2 TERMINATION TYPE : CRIMPING.
 - 2.3 CRIMP WIRE RANGE : 22~20AWG.
3. ALL DIMENSION ARE FOR REFERENCE USE ONLY.
4. ROHS COMPLIANT.

P/N	CONTACT PLATING(MATING AREA)
MS20W23F	GOLD FLASH PLATING OVER NICKEL.
MS20W23G10	10μ"GOLD PLATING OVER NICKEL.
MS20W23G15	15μ"GOLD PLATING OVER NICKEL.
MS20W23G30	30μ"GOLD PLATING OVER NICKEL.

QUANTITY	PART NUMBER	DESCRIPTION	ITEM
MATERIALS LIST			
<small>UNLESS OTHERWISE SPECIFIED</small> 1) All dimensions are in metric(mm). 2) Tolerances are as follows: 1 PL DEC ±0.30 2 PL DEC ±0.15 3 PL DEC ±0.08 Fractions ±1/64 Angles ±1° 3) Note reference =		SIGNATURES DRAWN: BEN CHECKED: ENGINEER: APPROVAL: DATE: JULY-1-2014	Amphenol Sine Systems - www.amphenol-sine.com 44724 Morley Drive Clinton Township, MI 48036
MATERIAL SPECIFICATIONS:		CUSTOMER:	ECO-MATE, SOCKET CONTACT MACHINE, 22-20AWG, SIZE 20
PROCESS SPECIFICATIONS:		<small>THIS DRAWING IS SUPPLIED FOR INFORMATION ONLY. DESIGN FEATURES, SPECIFICATIONS AND PERFORMANCE DATA SHOWN HEREON ARE THE PROPERTY OF THE AMPHENOL CORPORATION. NO RIGHTS OF REPRODUCTION ARE IMPLIED. ALL DIMENSIONS ARE SUBJECT TO NORMAL MANUFACTURING VARIATIONS.</small>	SIZE: B TYPE: C- DWG NO.: MS20W23xx REVISION: B1
NEXT ASSY:		SCALE: NONE	SHEET 1 OF 1

TITLE: ECO-MATE SOCKET CONTACT MACHINE, 22-20AWG, SIZE 20
 DWG NO.: MS20W23xx
 REV: B1
 SH: 1
 OF: 1