

- 1
- 2
- 3
- 4
- 5
- 6
- 7
- 8
- 9
- 10
- 11
- 12
- 13
- 14
- 15
- 16
- 17
- 18

## VIBRATION-DAMPING BODY

Natural rubber NR, black colour.

- **DVE**: hardness 40, 60 Shore A ±5.
- **DVE-SST**: hardness 60 Shore A ±5.

## STANDARD EXECUTIONS

- **DVE-A**: zinc-plated steel oval mounting flange, base plate and tapped boss.
- **DVE-SST-A**: AISI 304 stainless steel oval mounting flange, base plate and tapped boss.
- **DVE-B**: zinc-plated steel square mounting flange, base plate and tapped boss.
- **DVE-SST-B**: AISI 304 stainless steel square mounting flange, base plate and tapped boss.

## FEATURES AND APPLICATIONS

DVE vibration-damping elements are composed of two metallic elements joined together by a rubber anti-vibration body. A round element with a boss with a threaded pass-through hole constitutes the base for fixing the vibrating machine. Another element, oval or square shaped, constitutes the flange for fastening to the floor.

Generally used for applications with rotary machines that do not present big dynamic imbalances, where elasticity is required both vertically and transversely.

They are therefore very suitable for use with compressors, fans, vibrating feeders, rotary pumps or electric motors.

Vibrations can cause:

- malfunctioning and reduction of the machine lifespan and/or of the adjacent ones;
- noise and thus also damage to human health.

Load diagrams for each single code are available on request.

See Guidelines for the choice (on page 1136).

## SPECIAL EXECUTIONS ON REQUEST

- AISI 304 stainless steel elements and NR natural rubber with hardness 40 tolerance ± 5 Shore A.
- Executions with AISI 316 stainless steel mounting flange, base plate and tapped boss.
- Executions with NR natural rubber with different hardness.

### Conversion Table

1 mm = 0.039 inch

mm	inch
64	2.52
85	3.35
114	4.49
136	5.35
151	5.94



**DVE-A  
DVE-SST-A**

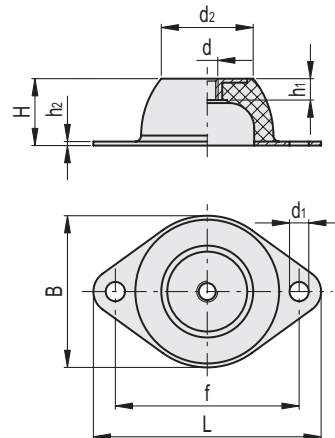

## DVE-A

Code	Description	B	L	H	d	h1	d1	h2	d2	f	Max load [N]	Max. deflection [mm]	Stiffness [N/mm]	Δ
434901	DVE-18-M6-A-40	43	64	20	M6	7	7	2	18	50	62.5	5	13	30
434903	DVE-18-M6-A-60	43	64	20	M6	7	7	2	18	50	141	5	28	30
434906	DVE-33-M8-A-40	56	85	25	M8	9	8	2	33	66	378	6.25	60	70
434908	DVE-33-M8-A-60	56	85	25	M8	9	8	2	33	66	617	6	103	70
434911	DVE-45-M10-A-40	76	114	35	M10	11	10	2	45	92	643	8.75	73	160
434913	DVE-45-M10-A-60	76	114	35	M10	11	10	2	45	92	1374	8.75	157	160
434916	DVE-53-M10-A-40	96	136	40	M10	11	11,5	2	53	110	855	10	86	265
434918	DVE-53-M10-A-60	96	136	40	M10	11	11,5	2	53	110	2307	10	231	265
434921	DVE-58-M10-A-40	101	151	45	M10	11	11,5	3	58	124	1785	11.25	159	400
434923	DVE-58-M10-A-60	101	151	45	M10	11	11,5	3	58	124	3230	11.25	287	400

## DVE-SST-A

Code	Description	B	L	H	d	h1	d1	h2	d2	f	Max load [N]	Max. deflection [mm]	Stiffness [N/mm]	Δ
434951	DVE-18-SST-M6-A-60	43	64	20	M6	7	7	2	18	50	141	5	28	30
434956	DVE-33-SST-M8-A-60	56	85	25	M8	9	8	2	33	66	617	6	103	70
434961	DVE-45-SST-M10-A-60	76	114	35	M10	11	10	2	45	92	1374	8.75	157	160
434966	DVE-53-SST-M10-A-60	96	136	40	M10	11	11,5	2	53	110	2307	10	231	265
434971	DVE-58-SST-M10-A-60	101	151	45	M10	11	11,5	3	58	124	3230	11.25	287	400

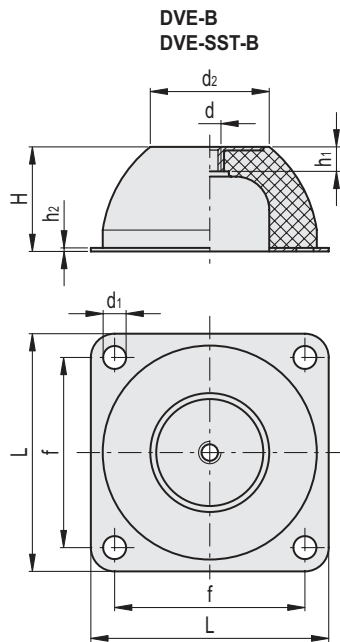

Conversion Table	
1 mm = 0.039 inch	
L	
mm	inch
64	2.52
85	3.35
114	4.49
136	5.35
151	5.94

DVE-B

METRIC

Code	Description	L	H	d	h1	d1	h2	d2	f	Max load [N]	Max. deflection [mm]	Stiffness [N/mm]	⚖️
434926	DVE-78-M12-B-40	150	63	M12	13	14,5	3	78	120	3073	15.75	195	1025
434928	DVE-78-M12-B-60	150	63	M12	13	14,5	3	78	120	7470	15.75	474	1025
434931	DVE-100-M16-B-40	200	85	M16	16	14,5	3	100	160	8486	21.25	399	2315
434933	DVE-100-M16-B-60	200	85	M16	16	14,5	3	100	160	9770	20	488	2315
434936	DVE-186-M24-B-40	310	160	M24	40	18	4	186	250	10528	40	263	10500
434938	DVE-186-M24-B-60	310	160	M24	40	18	4	186	250	20812	46.5	448	10500

DVE-SST-B

INOX STAINLESS STEEL METRIC

Code	Description	L	H	d	h1	d1	h2	d2	f	Max load [N]	Max. deflection [mm]	Stiffness [N/mm]	⚖️
434976	DVE-78-SST-M12-B-60	150	63	M12	13	14,5	3	78	120	7470	15.75	474	1025
434981	DVE-100-SST-M16-B-60	200	85	M16	16	14,5	3	100	160	9770	20	488	2315
434986	DVE-186-SST-M24-B-60	310	160	M24	40	18	4	186	250	20812	46.5	448	10500