

## Description

The ICS7152-01, -02, -11, and -12 are clock generators for EMI (Electro Magnetic Interference) reduction (see below for frequency ranges and multiplier ratios). Spectral peaks can be attenuated by slightly modulating the oscillation frequency. Both down and center spread profiles are selectable. Center spread maintains an average frequency equal to an unspread clock. Down spread meets maximum frequency specs over the entire modulation cycle.

## Features

- Operating voltage of 3.3 V  $\pm$ 0.3 V
- Packaged in 8-pin SOIC
- Input frequency range of 16.6 to 134.0 MHz
- Output frequency range of 16.6 to 134.0 MHz
- Provides a spread spectrum clock output ( $\pm$ 0.5%,  $\pm$ 1.5% center spread; -1.0%, -3.0% down spread)
- Advanced, low-power CMOS process
- Industrial temperature range available
- Pb (lead) free package, RoHS compliant

## Block Diagram

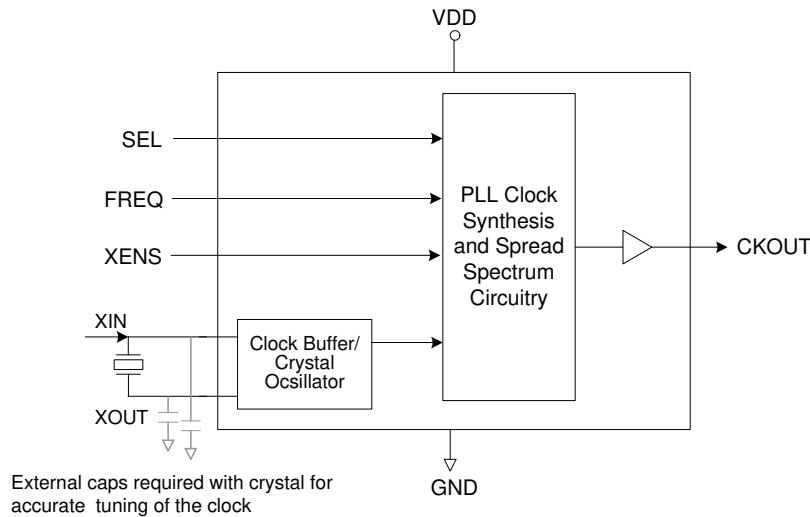

## Product Lineup

Product	Input Frequency Range	Modulation Type	Modulation Enable Pin
ICS7152M-01, ICS7152MI-01	16.6 MHz to 67 MHz	Down spread	Yes
ICS7152M-02, ICS7152MI-02	40.0 MHz to 134.0 MHz		
ICS7152M-11, ICS7152MI-11	16.6 MHz to 67.0 MHz	Center spread	
ICS7152M-12, ICS7152MI-12	40.0 MHz to 134.0 MHz		

## Pin Assignment

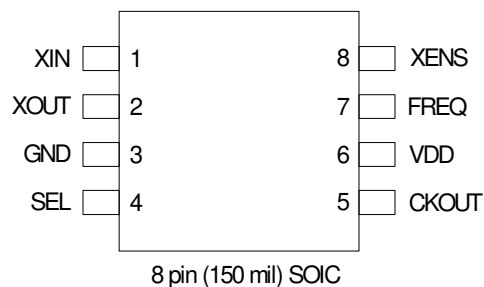

## SEL Modulation Rate Setting Table

SEL Pin 4 (note1)	Spread Direction	Spread Percentage (%)	Part Number
0	Center	±0.5	ICS7152M-11, ICS7152M-12
	Down	-1.0	ICS7152M-01, ICS7152M-02
1	Center	±1.5	ICS7152M-11, ICS7152M-12
	Down	-3.0	ICS7152M-01, ICS7152M-02

## Modulation Enable Setting Table

XENS Pin 8	Spread Spectrum
0	ON
1	OFF

## Frequency Setting Table

FREQ Pin 7	Frequency	
0	16.6 to 40 MHz	ICS7152M-01, ICS7152M-11
	40 to 80 MHz	ICS7152M-02, ICS7152M-12
1	33 to 67 MHz	ICS7152M-01, ICS7152M-11
	66 to 134 MHz	ICS7152M-02, ICS7152M-12

## Pin Descriptions

Pin Number	Pin Name	Pin Type	Pin Description
1	XIN	Input	Crystal resonator connection pin/clock input pin.
2	XOUT	Output	Crystal resonator connection pin.
3	GND	Power	Connect to ground.
4	SEL	Input	Modulation rate setting pin.
5	CKOUT	Output	Modulated clock output pin.
6	VDD	Power	Connect to +3.3 V.
7	FREQ	Input	Frequency setting pin.
8	XENS	Input	Modulation enable setting pin.

## External Components

The ICS7152 requires a minimum number of external components for proper operation.

### Decoupling Capacitor

A decoupling capacitor of 0.01 $\mu$ F must be connected between GND and VDD on pin 6, as close to this pin as possible. For optimum device performance, the decoupling capacitor should be mounted on the component side of the PCB. Avoid the use of vias in the decoupling circuit.

### Series Termination Resistor

Series termination should be used on the clock output. To series terminate a 50 $\Omega$  trace (a commonly used trace impedance) place a 27 $\Omega$  resistor in series with the clock line, as close to the clock output pin as possible. The nominal impedance of the clock output is 25 $\Omega$ .

## PCB Layout Recommendations

For optimum device performance and lowest output phase noise, the following guidelines should be observed.

1) An optimum layout is one with all components on the same side of the board, minimizing vias through other signal layers. Other signal traces should be routed away from the ICS7152. This includes signal traces just underneath the device, or on layers adjacent to the ground plane layer used by the device.

## Crystal Information

The crystal used should be a fundamental mode, parallel resonant. Crystal capacitors should be connected from pins X1 to ground and X2 to ground to optimize the initial accuracy. The value of these capacitors is given by the following equation:

$$\text{Crystal caps (pF)} = (C_L - 6) \times 2$$

In the equation,  $C_L$  is the crystal load capacitance. So, for a crystal with a 16 pF load capacitance, two 20 pF [(16-6) x 2] capacitors should be used.

## Spread Spectrum Profile

The ICS7152 low EMI clock generator uses a triangular frequency modulation profile for optimal down stream tracking of zero delay buffers and other PLL devices. The frequency modulation amplitude is constant with variations of the input frequency.

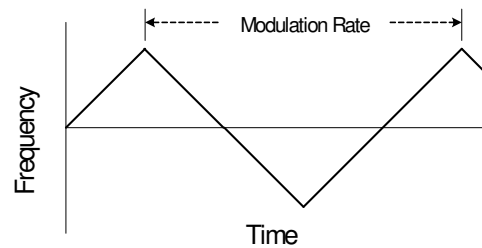

## Absolute Maximum Ratings

Stresses above the ratings listed below can cause permanent damage to the ICS7152. These ratings, which are standard values for IDT commercially rated parts, are stress ratings only. Functional operation of the device at these or any other conditions above those indicated in the operational sections of the specifications is not implied. Exposure to absolute maximum rating conditions for extended periods can affect product reliability. Electrical parameters are guaranteed only over the recommended operating temperature range.

Item	Rating
Supply Voltage, VDD	7 V
All Inputs and Outputs (referenced to GND)	-0.5 V to VDD+0.5 V
Ambient Operating Temperature	-40 to +85° C
Storage Temperature	-55 to +125° C
Junction Temperature	-40 to +125° C
Soldering Temperature	260° C
Overshoot ( $V_{IOVER}$ )	VDD + 1.0 V ( $t_{OVER} \leq 50$ ns) max
Undershoot ( $V_{IUNDER}$ )	GND - 1.0 V ( $t_{UNDER} \leq 50$ ns) min

### Overshoot/Undershoot

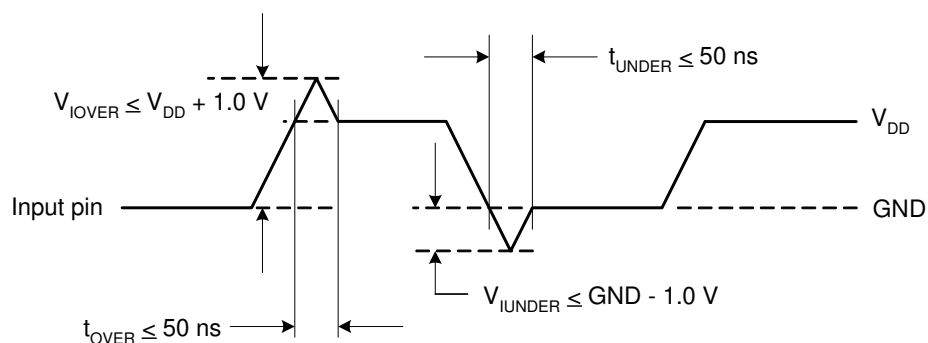

## Recommended Operation Conditions

Parameter	Min.	Typ.	Max.	Units
Ambient Operating Temperature	-40		+85	°C
Power Supply Voltage (measured in respect to GND)	+3.0	3.3	3.6	V

## DC Electrical Characteristics

Unless stated otherwise,  $V_{DD} = 3.3 \text{ V} \pm 0.3 \text{ V}$ , Ambient Temperature  $-40$  to  $+85^\circ \text{C}$

Parameter	Symbol	Conditions	Min.	Typ.	Max.	Units
Operating Voltage	VDD		3.0	3.3	3.6	V
Supply Current	IDD	No load, at 3.3 V		14	28	mA
Input High Voltage	$V_{IH}$	SEL, FREQ, XENS	$V_{DD} \times 0.8$		$V_{DD} + 0.3$	V
		XIN, Input slew rate 3 V/ns, 16.6 to 100 MHz	$V_{DD} \times 0.8$		$V_{DD} + 0.3$	V
		XIN, Input slew rate 3 V/ns, 100 to 134 MHz	$V_{DD} \times 0.9$		$V_{DD} + 0.3$	V
Input Low Voltage	$V_{IL}$	SEL, FREQ, XENS	GND		$V_{DD} \times 0.20$	V
		XIN, Input slew rate 3 V/ns, 16.6 to 100 MHz	GND		$V_{DD} \times 0.20$	V
		XIN, Input slew rate 3 V/ns, 100 to 134 MHz	GND		$V_{DD} \times 0.10$	V
Output High Voltage	$V_{OH}$	CKOUT, $I_{OH} = -4 \text{ mA}$	$V_{DD} - 0.5$		VDD	V
Output Low Voltage	$V_{OL}$	CKOUT, $I_{OL} = 4 \text{ mA}$	GND		0.4	V
Input Capacitance	$C_{IN}$	XIN, SEL, XENS			16	pF
Load Capacitance	$C_L$	CKOUT, 16.6 to 67 MHz			15	pF
		CKOUT, 67 to 100 MHz			10	pF
		CKOUT, 100 to 134 MHz			7	pF
Output Impedance	$Z_O$	CKOUT, 16.6 to 134 MHz		25		$\Omega$

## AC Electrical Characteristics

Unless stated otherwise,  $V_{DD} = 3.3\text{ V} \pm 0.3\text{ V}$ , Ambient Temperature  $-40$  to  $+85^\circ\text{ C}$

Parameter	Symbol	Conditions	Min.	Typ.	Max.	Units
Input Crystal Frequency			16.6		40	MHz
Input Clock Frequency	$f_{IN}$	ICS7152-01, -11	16.6		67	MHz
		ICS7152-02, -12	40		134	MHz
Output Frequency	$f_{OUT}$	CKOUT, ICS7152-01, -11	16.6		67	MHz
		CKOUT, ICS7152-02, -12	40		134	MHz
Input Clock Duty Cycle	$t_{DCI}$	XIN, 16.6 to 100 MHz	40	50	60	%
		XIN, 100 to 134 MHz	45	50	55	%
Output Clock Duty Cycle	$t_{DCC}$	CKOUT, 1.5 V	40		60	%
Output Slew Rate		CKOUT, 0.4 to 2.4 V, CL = 15 pF	0.5		3.0	V/ns
Cycle-to-Cycle Jitter	$t_{JC}$	No load, spread off, ICS7152-01, -02			150	ps
		No load, spread off, ICS7152-11, -12			250	
		No load, spread off, ICS7152-01, 33.33 MHz, SEL = 0, FREQ = 1			120	
Power-up Time		PLL lock-time from power-up to 1% of final value		2	5	ms
Modulation Frequency	$f_{MOD}$	CKOUT		33		kHz

### Input Frequency ( $f_{IN} = 1/t_{IN}$ )

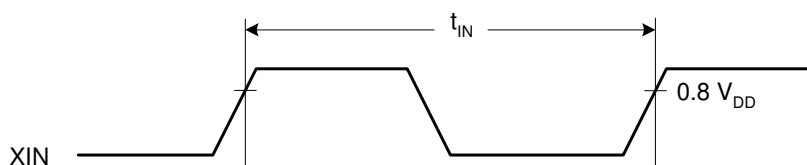

### Output Slew Rate

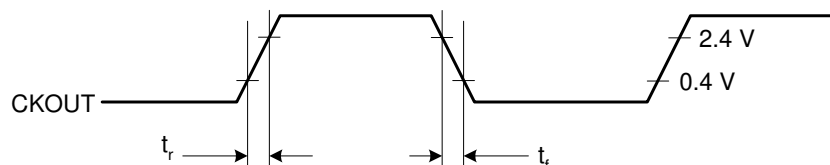

$$SR = (2.4 - 0.4) / t_r, SR = (2.4 - 0.4) / t_f$$

## Thermal Characteristics 8 SOIC

Parameter	Symbol	Conditions	Min.	Typ.	Max.	Units
Thermal Resistance Junction to Ambient	$\theta_{JA}$	Still air		150		$^{\circ}C/W$
	$\theta_{JA}$	1 m/s air flow		140		$^{\circ}C/W$
	$\theta_{JA}$	3 m/s air flow		120		$^{\circ}C/W$
Thermal Resistance Junction to Case	$\theta_{JC}$			40		$^{\circ}C/W$

## Package Outline and Package Dimensions (8-pin SOIC, 150 Mil. Body)

Package dimensions are kept current with JEDEC Publication No. 95

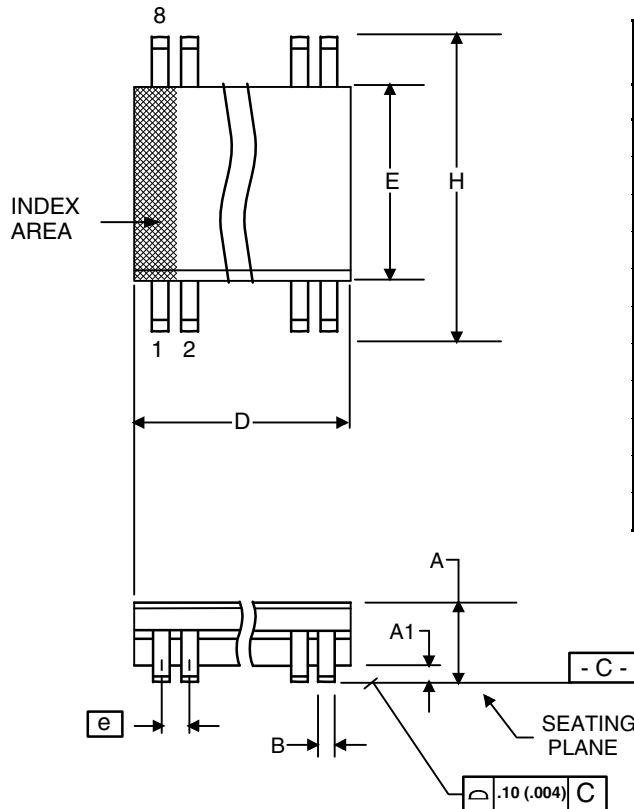

Symbol	Millimeters		Inches	
	Min	Max	Min	Max
A	1.35	1.75	.0532	.0688
A1	0.10	0.25	.0040	.0098
B	0.33	0.51	.013	.020
C	0.19	0.25	.0075	.0098
D	4.80	5.00	.1890	.1968
E	3.80	4.00	.1497	.1574
e	1.27 BASIC		0.050 BASIC	
H	5.80	6.20	.2284	.2440
h	0.25	0.50	.010	.020
L	0.40	1.27	.016	.050
$\alpha$	0°	8°	0°	8°

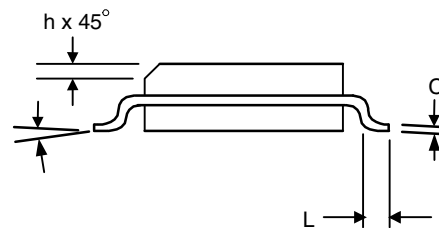



## Ordering Information

Part / Order Number	Marking	Shipping Packaging	Package	Temperature
7152M-01LF	52M-01LF	Tubes	8-pin SOIC	0 to +70° C
7152M-01LFT	52M-01LF	Tape and Reel	8-pin SOIC	0 to +70° C
7152MI-01LF	52MI01LF	Tubes	8-pin SOIC	-40 to +85° C
7152MI-01LFT	52MI01LF	Tape and Reel	8-pin SOIC	-40 to +85° C
7152M-02LF	7152M02L	Tubes	8-pin SOIC	0 to +70° C
7152M-02LFT	7152M02L	Tape and Reel	8-pin SOIC	0 to +70° C
7152MI-02LF	52MI02LF	Tubes	8-pin SOIC	-40 to +85° C
7152MI-02LFT	52MI02LF	Tape and Reel	8-pin SOIC	-40 to +85° C
7152M-11LF	7152M11L	Tubes	8-pin SOIC	0 to +70° C
7152M-11LFT	7152M11L	Tape and Reel	8-pin SOIC	0 to +70° C
7152MI-11LF	52MI11LF	Tubes	8-pin SOIC	-40 to +85° C
7152MI-11LFT	52MI11LF	Tape and Reel	8-pin SOIC	-40 to +85° C
7152M-12LF	52M-12LF	Tubes	8-pin SOIC	0 to +70° C
7152M-12LFT	52M-12LF	Tape and Reel	8-pin SOIC	0 to +70° C
7152MI-12LF	52MI12LF	Tubes	8-pin SOIC	-40 to +85° C
7152MI-12LFT	52MI12LF	Tape and Reel	8-pin SOIC	-40 to +85° C

**"LF" suffix to the part number are the Pb-Free configuration and are RoHS compliant.**

While the information presented herein has been checked for both accuracy and reliability, Integrated Device Technology (IDT) assumes no responsibility for either its use or for the infringement of any patents or other rights of third parties, which would result from its use. No other circuits, patents, or licenses are implied. This product is intended for use in normal commercial applications. Any other applications such as those requiring extended temperature range, high reliability, or other extraordinary environmental requirements are not recommended without additional processing by IDT. IDT reserves the right to change any circuitry or specifications without notice. IDT does not authorize or warrant any IDT product for use in life support devices or critical medical instruments.



## IMPORTANT NOTICE AND DISCLAIMER

RENESAS ELECTRONICS CORPORATION AND ITS SUBSIDIARIES (“RENESAS”) PROVIDES TECHNICAL SPECIFICATIONS AND RELIABILITY DATA (INCLUDING DATASHEETS), DESIGN RESOURCES (INCLUDING REFERENCE DESIGNS), APPLICATION OR OTHER DESIGN ADVICE, WEB TOOLS, SAFETY INFORMATION, AND OTHER RESOURCES “AS IS” AND WITH ALL FAULTS, AND DISCLAIMS ALL WARRANTIES, EXPRESS OR IMPLIED, INCLUDING, WITHOUT LIMITATION, ANY IMPLIED WARRANTIES OF MERCHANTABILITY, FITNESS FOR A PARTICULAR PURPOSE, OR NON-INFRINGEMENT OF THIRD PARTY INTELLECTUAL PROPERTY RIGHTS.

These resources are intended for developers skilled in the art designing with Renesas products. You are solely responsible for (1) selecting the appropriate products for your application, (2) designing, validating, and testing your application, and (3) ensuring your application meets applicable standards, and any other safety, security, or other requirements. These resources are subject to change without notice. Renesas grants you permission to use these resources only for development of an application that uses Renesas products. Other reproduction or use of these resources is strictly prohibited. No license is granted to any other Renesas intellectual property or to any third party intellectual property. Renesas disclaims responsibility for, and you will fully indemnify Renesas and its representatives against, any claims, damages, costs, losses, or liabilities arising out of your use of these resources. Renesas' products are provided only subject to Renesas' Terms and Conditions of Sale or other applicable terms agreed to in writing. No use of any Renesas resources expands or otherwise alters any applicable warranties or warranty disclaimers for these products.

(Disclaimer Rev.1.0 Mar 2020)

### Corporate Headquarters

TOYOSU FORESIA, 3-2-24 Toyosu,  
Koto-ku, Tokyo 135-0061, Japan  
[www.renesas.com](http://www.renesas.com)

### Contact Information

For further information on a product, technology, the most up-to-date version of a document, or your nearest sales office, please visit:  
[www.renesas.com/contact/](http://www.renesas.com/contact/)

### Trademarks

Renesas and the Renesas logo are trademarks of Renesas Electronics Corporation. All trademarks and registered trademarks are the property of their respective owners.