



Automatic Compliance Made Quick & Easy...

Keep energized electrical equipment closed during ultrasound inspection, and easily comply with OSHA, NFPA 70E, CSA Z462 and similar electrical safety mandates.

Closed-panel inspections eliminate inherently high-risk tasks, such as removing panels or opening hinged doors, making your work processes safer for personnel, plant assets and processes.

Inspection ports provide direct line-of-site access to ultrasonic waves that are otherwise not accessible from equipment with tight seals.

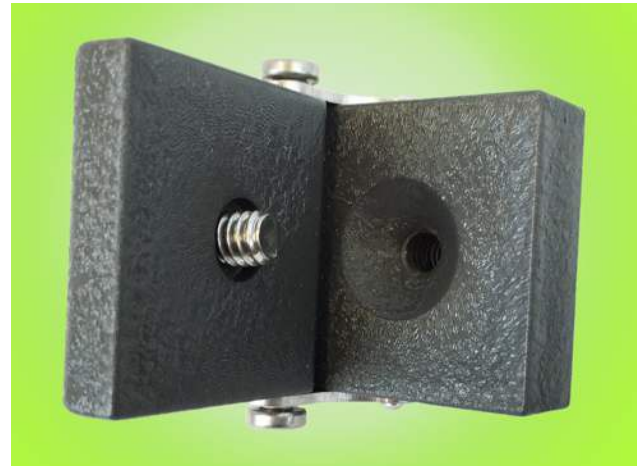

Access the Inaccessible:

How does your facility perform ultrasound inspections on equipment that is tightly sealed or can no longer be opened while energized due to that equipment's voltage or incident energy rating? How does your facility inspect equipment protected by switched interlocks? Ultrasound ports provide safe access to "inaccessible" energized equipment.

Analyze Better Data:

Exiscan™ Ultrasound Ports feature a conical backend to capture and focus ultrasonic waves from broad angles within the equipment. Conical front-end allows for the technician to angle data-collection cones for line-of-site aim through the port of over 45° for direct access to most components in switchgear.

Over-Engineered for Your Safety

The XUP series is built to out-live your enclosure. Our port's body and cover are machined from half-inch bar stock aluminum. All other components are stainless steel.

When it comes to durability and brute strength, Exiscan® is without peers. See it for yourself, contact your local Distributor.

Patent Pending



Anatomy of an Ultrasound Port

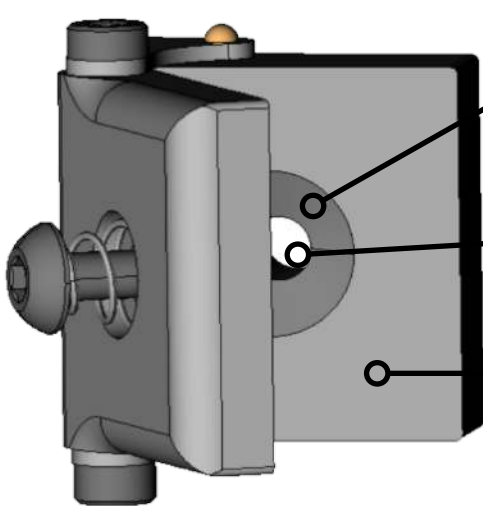

Conical Opening:

- Reverse parabolic cone tool from portable ultrasound instrument easily pivots in all directions to locate source(s) of ultrasonic emissions.

1/4" (6.4 mm) Diameter Opening:

- Complies with UL and IP standards for finger safe.

Window Body & Cover:

- Machined from 1/2" aluminum bar stock for unmatched resilience (stainless steel available).
- Treated with Mil Spec anodizing process and then powder coated for "belt and suspenders" protection against industrial environments.
- Cover mounted on stainless steel hinges for ease of use and captivated component .
- Cover fastens with 1/4-28 stainless steel, spring loaded, captive screw for a safe, secure seal.

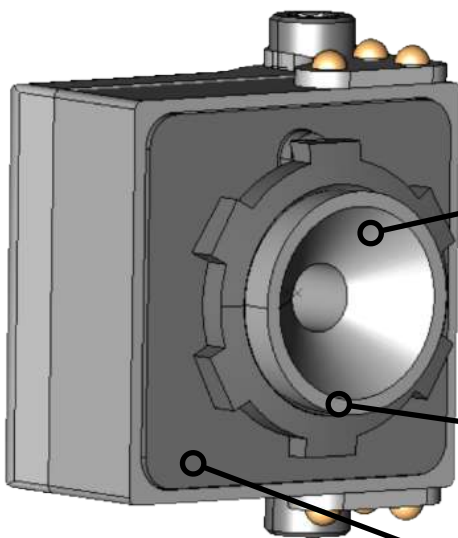

Conical Backend:

- Shaped to capture ultrasonic waves from wide angles and draw them to the opening for analysis, while allowing technicians broad angles to determine the precise origination of anomalies.

Mounting Fitting:

- Uses standard 1/2" conduit knockout and conduit nut for easy installation.

Gasket:

- NEMA 4X seal for indoor and outdoor use.



XPort Ultrasound Inspection Port

Material Specifications	
Body & Cover Material	Aluminum: Anodized & Powder Coated (Stainless Steel Available)
Hardware & Fasteners	Stainless Steel
Conduit Nut	Nickel-Plated 1/2" Conduit Nut
Gasket	Neoprene
Cover Screw*	Stainless Steel, 1/4-20, Captive
Dimension Specifications (nom.)	
Body and Cover (L x H)	1.5 in x 1.5 in (38 mm) x (38 mm)
Total Width (Body + Cover)	0.9 in (23 mm)
Cover Thickness	0.4 in (10 mm)
Port Aperture Dimension	0.25 in (6.4 mm) Diameter
Standards	
NEMA Environmental Rating	NEMA 4X (Closed)
Ingress Protection (IP)	IP66 (Closed), IP20 (Open)
General	
Voltage Range	Low, Medium & High
Grounding	Automatically grounds when mounted to grounded panel/door
Operating Temperature	-40°C (-40°F) to 150°C (300°F)
Installation	Standard 1/2" Conduit Punch
Lifetime Warranty	Unconditional for Materials & Workmanship
Country of Origin	Proudly Made in the USA

*Standard Cover Screw Type: Allen Head (5/32" Hex Socket). Other options available.



Quick & Easy Installation:

The XIR infrared Windows require a one-time modification to the enclosure. A qualified person simply cuts a 1/2" diameter opening in the panel or door.

The opening can be cut with a standard 1/2" knockout punch, hole saw, or uni-bit tool. Properly equipped, a team of two technicians can install eight to 10 ultrasound ports an hour.



Alfra Knockout Punch Kit

Ordering Information:

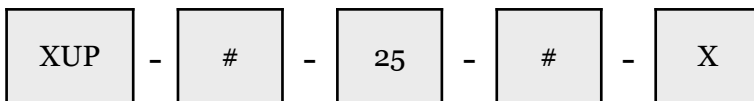

Body/Cover Material:
A = Aluminum - Anodized & Powder Coated (Standard)
S = Stainless Steel

Cover Screw Type:
H = Hex Head Screws (Standard)
S = Hex Safety Screw
P = Philips Head Screw
T = Torx Head Screw
X = Torx Safety Screw

