



SY88432L

4.25 Gbps Transceiver with Integrated FP/DFB Laser Diode Driver and Limiting Post Amplifier

General Description

The SY88432L is a low power transceiver device that integrates a 4.25Gbps FP/DFB laser diode driver with a wide-sensitivity limiting post amplifier. This low power device is designed for use in fiber-optic optical modules for multi-rate applications up to 4.25Gbps.

The SY88432L transmitter section can output up to 60mA of modulation current with fast rise and fall times and is designed to be AC-coupled to the laser. The transmitter output stage incorporates a transmit disable feature and integrated 50Ω input impedance referenced to V_{CC} .

The receiver section's limiting post amplifier connects to a typical trans-impedance amplifier (TIA) to amplify the incoming weak signal from the ROSA and outputs normalized received data in CML format at the output.

The receiver offers a wide LOS (Loss Of Signal) Assert range between 8mV_{PP} to 40mV_{PP} differential. A programmable loss-of-signal level set pin (LOSLVL) sets the sensitivity of the input amplitude detection. The LOS or SD (signal-detect) is user selectable and the LOS/SD signal can be fed back to the JAM input to implement the SQUELCH function that maintains output stability under a loss-of-signal condition. The receiver input should be AC-coupled.

The SY88432L interfaces with Micrel's highly advanced optical module controller MIC3003 as an easy-to-use chipset solution for CSFP/SFP/CSFF/SFF optical module applications. The MIC3003 allows for both modulation and bias current control, with automatic power control (APC) and temperature compensation.

The SY88432L operates on a single 3.3V power supply and is available in a 24 lead, 4x4mm QFN package.

All support documentation can be found on Micrel's web site at: www.micrel.com.

Features

- Multi-rate operation up to 4.25Gbps
- Single, wide range power supply: 3.3V ±10%
- Industrial temp range: -40°C to +85°C
- MIC3003 compatible

Transmitter – FP/DFB Laser Diode Driver

- Modulation current up to 60mA
 - AC coupled laser diode modulation
 - Voltage controlled modulation current
- Rise/Fall times 65ps (typical)
- TX Disable with internal 75kΩ pull down resistor
- Integrated 50Ω input impedance to V_{CC}

Receiver – Limiting Post Amplifier

- Wide differential input range (10mV_{pp} – 1800mV_{pp})
- Programmable LOS level (LOSLVL) sensitivity
- Wide LOS Assert range (8mV_{pp} – 40mV_{pp})
 - With 3.5dB typical electrical hysteresis
- Selectable LOS or SD output
- TTL compatible JAM input with internal pull up
- Low-noise CML data outputs with integrated 50Ω termination impedance
 - Rise/Fall times 60ps (typical)
- Low-noise CML data inputs with integrated 50Ω termination impedance to internal reference V_{REF}

Applications

- Gigabit Ethernet
- Fibre Channel – 1FC, 2FC, 4FC
- SONET OC3/12/24/48 and with FEC
- SDH STM1/4/8/16 and with FEC

Markets

- Datacom / Telecom / Storage
- Compact SFP/SFF Optical transceiver
- SFP/SFF Optical transceiver
- Wireless backhaul

Pin Configuration

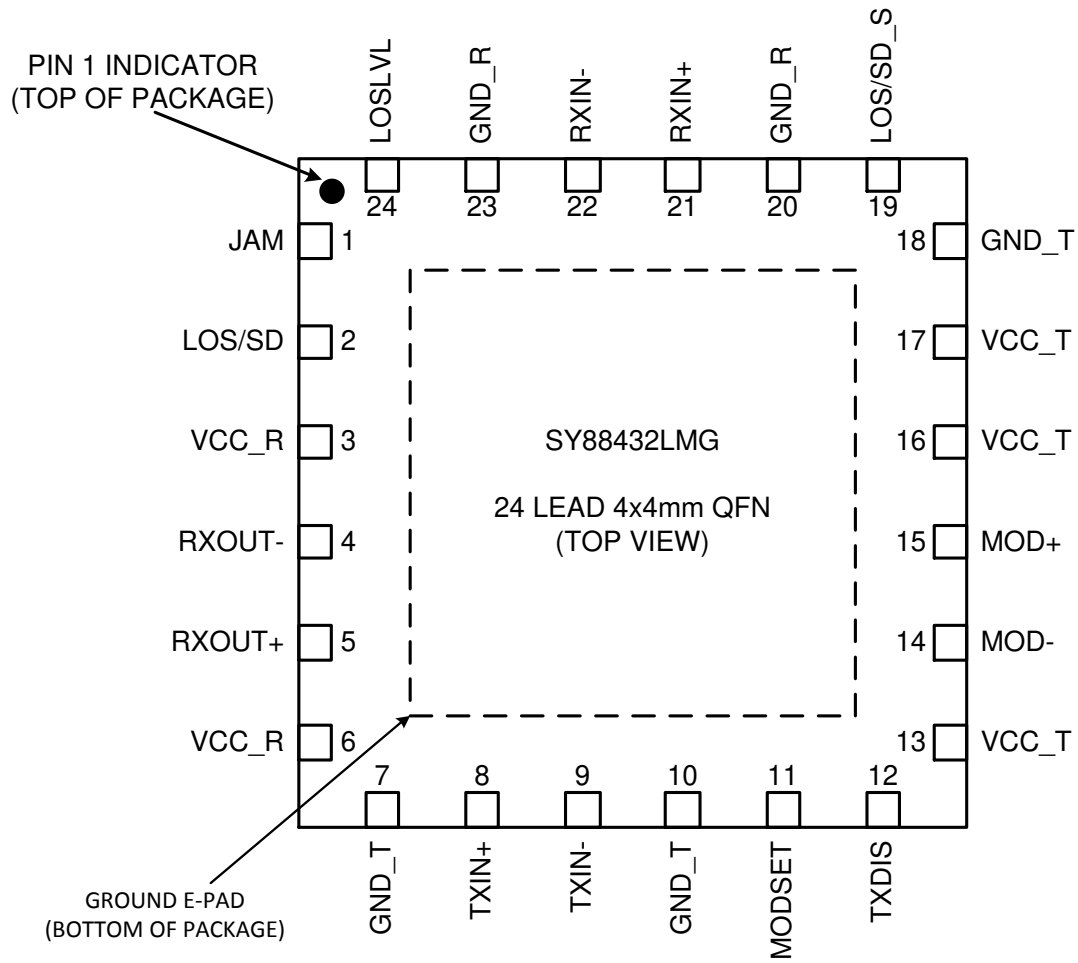

NOTE:
 E-PAD MUST BE CONNECTED TO
 THE PCB GROUND PLANE USING
 THE CORRECT VIA ARRAY

24 Lead QFN (4x4mm)

Pin Description

Pin Number	Pin Name	Type	Pin Function
1	JAM	Logic Level Input	Active Low TTL Input. Determines whether the post amp output is enabled or disabled. Operation when LOS/SD = LOS is selected: HIGH = Post amp output is Disabled. LOW = Post amp output is Enabled. Operation when LOS/SD = SD is selected: HIGH = Post amp output is Enabled. LOW = Post amp output is Disabled. Default: Internally pulled-up with 25k Ω . Can be shorted to LOS/SD (pin 2) to create a SQUELCH function.
2	LOS/SD	Logic Level Output	Loss-of-Signal / Signal-Detect. Determined by LOS/SD_S pin setting. Operation when LOS is selected by LOS/SD_S pin setting: HIGH = when the data input amplitude falls below the threshold set by LOSLVL. LOW = when the data input amplitude rises above the threshold set by LOSLVL. Operation when SD is selected by LOS/SD_S pin setting: HIGH = when the data input amplitude rises above the threshold set by LOSLVL. LOW = when the data input amplitude falls below the threshold set by LOSLVL.
4, 5	RXOUT-, RXOUT+	CML Outputs	Receiver Differential CML Outputs. Unused output should be terminated 50 Ω to V _{CC} .
8, 9	TXIN+, TXIN-	CML Inputs	Transmitter Differential Data CML Inputs. Data input signals for the laser diode driver section internally terminated with 50 Ω to V _{CC} .
11	MODSET	Analog Input	Modulation Current Setting and Control. The modulation current is set by applying a voltage between 0V and 1.2V to this pin. 5k Ω input impedance.
12	TXDIS	Logic Level Input	Transmit Disable. Control signal that enables or disables the laser diode driver outputs. HIGH = Transmitter outputs are set as follows: MOD+ = HIGH; MOD- = LOW LOW = Transmitter outputs Enabled. Default: Internally pulled down with a 75k Ω resistor.
14, 15	MOD-, MOD+	Transmitter Output	Modulation current output. Must be AC coupled to the laser.
19	LOS/SD_S	Logic Level Input	LOS/SD Output Select. Determines whether LOS or SD is selected. HIGH = SD is selected on the LOS/SD output and JAM logic operation is: when JAM = High \rightarrow Post amplifier output is Enabled. LOW = LOS is selected on the LOS/SD output and JAM logic operation is: when JAM = Low \rightarrow Post amplifier output is Enabled. Default: Internally pulled up with a 25k Ω resistor.
21, 22	RXIN+, RXIN-	Receiver Inputs	Receiver Differential Data Inputs. Each input is internally terminated to V _{REF} (V _{CC} – 1.3V) with 50 Ω resistors. Inputs are AC-coupled.
24	LOSLVL	Analog Input	Loss-of-Signal Level Set. A resistor from this pin to V _{CC} sets the threshold for the data input amplitude at which LOS/SD will be asserted.
3, 6	VCC_R	Receiver Positive Supply Rail	Receiver Voltage Supply. Bypass with a 0.1 μ F 0.01 μ F low ESR capacitor as close to VCC_R pin as possible.

Pin Description

Pin Number	Pin Name	Type	Pin Function
7, 10, 18	GND_T	Transmitter Ground	Transmitter Ground. Connect to the PCB ground plane.
13, 16, 17	VCC_T	Transmitter Positive Supply Rail	Transmitter Voltage Supply. Bypass with a 0.1uF 0.01uF low ESR capacitor as close to VCC_T pin as possible.
20, 23, e-pad	GND_R	Receiver Ground	Receiver Ground. Connect to the PCB ground plane. The e-pad must be connected to the PCB ground plane using a via array to transfer the heat from the package to the PCB ground plane.

Transmitter - Laser Diode Driver Truth Table

TXIN+	TXIN-	TXDIS	MOD+ ⁽³⁾	MOD-	Laser Output ⁽⁴⁾
L	H	L	H	L	L
H	L	L	L	H	H
X	X	H	H	L	L

Notes:

3. $I_{MOD} \leq I_{MOD_OFF}$ when MOD+ is HIGH.
4. Assuming that Laser is tied to MOD+

Absolute Maximum Ratings⁽⁵⁾

Supply Voltage (V_{CC})	-0.5V to +4.0V
Input Voltage (V_{IN})	-0.5V to V_{CC}
TTL Control Input Voltage (V_{IN})	0V to V_{CC}
Lead Temperature (soldering, 20 sec.)	+260°C
Storage Temperature (T_S)	-65°C to +150°C

Operating Ratings⁽⁶⁾

Supply Voltage (V_{CC})	+3.00V to +3.60V
Ambient Temperature (T_A)	-40°C to +85°C
Package Thermal Resistance ⁽⁷⁾	
Still-Air (θ_{JA})	50°C/W
Junction-to-Board (θ_{JB})	30.5°C/W

Notes:

- Permanent device damage may occur if absolute maximum ratings are exceeded. This is a stress rating only and functional operation is not implied at conditions other than those detailed in the operational sections of this data sheet. Exposure to absolute maximum ratings conditions for extended periods may affect device reliability.
- The data sheet limits are not guaranteed if the device is operated beyond the operating ratings.
- Package Thermal Resistance assumes exposed pad is soldered (or equivalent) to the devices most negative potential on the PCB using the recommended via pattern and size. Assumes a 4 layer PCB and still air.

Transceiver DC Electrical Characteristics⁽⁸⁾

$V_{CC} = 3.3V \pm 10\%$, $T_A = -40^\circ\text{C}$ to $+85^\circ\text{C}$. Typical values are $V_{CC} = 3.3V$, $T_A = 25^\circ\text{C}$, $I_{MOD} = 60\text{mA}$

Symbol	Parameter	Condition	Min	Typ	Max	Units
I_{CC}	Power Supply Current	Without Modulation & Bias currents		90	130	mA
V_{IL}	TXDIS, LOS/SD_S, JAM, Input Low		-0.3		0.8	V
V_{IH}	TXDIS, LOS/SD_S, JAM, Input High		2		$V_{CC} + 0.3$	V
I_{IH}	TXDIS, LOS/SD_S, JAM, Input High	$V_{IN} = V_{CC}$; Note 10			20	μA
I_{IL}	TXDIS, LOS/SD_S, JAM, Input Low	$V_{IN} = 0.5V$; Note 10	-0.3			mA
V_{OH}	LOS Output High Level	$V_{CC} = 3.3V$. $I_{OH} < 50\mu\text{A}$	2			V
V_{OL}	LOS Output Low Level	$I_{OL} = 2\text{mA}$			0.5	V
I_{OH}	LOS Output Leakage	$V_{OH} = V_{CC}$			100	μA

Laser Diode Driver Electrical Characteristics⁽⁸⁾

$V_{CC} = 3.3V \pm 10\%$, $T_A = -40^\circ\text{C}$ to $+85^\circ\text{C}$. Typical values are $V_{CC} = 3.3V$, $T_A = 25^\circ\text{C}$, $I_{MOD} = 60\text{mA}$

Symbol	Parameter	Condition	Min	Typ	Max	Units
	Data Rate	NRZ Data	0.155		4.25	Gbps
$R_{IIN(TXIN)}$	Input resistance (TXIN+, TXIN-)		45	50	55	Ω
$R_{IIN(MOD_SET)}$	Input resistance (MODSET)			5		k Ω
V_{ID}	Differential Input Voltage Swing	CML inputs	300		800	mV _{PP}
V_{MODSET}	Voltage Range on MODSET Pin		0		1.2	V
V_{MOD}	Voltage (MOD+, MOD-)	Note 9	$V_{CC} - 1.5$		V_{CC}	V
I_{MOD}	Modulation Current	AC-Coupled	10		60	mA
I_{MOD_OFF}	Modulation OFF current	MOD+ current when the device is disabled (TXDIS = HIGH)			200	μA
J_{TOTAL}	Total Jitter	@ 4.25Gbps data rate		20		ps
T_{PDIS}	Pulse-Width Distortion	I_{MOD} range 10mA – 60mA		20		ps
t_r, t_f	Output Rise/Fall Times (20% to 80%)	15 Ω Load		65	80	ps

Notes:

- Specification for packaged product only.
- MOD+ and MOD- are current outputs. This defines the voltage range the user must guarantee these pins remain within for proper operation.
- TXDIS signal has an internal 75k Ω pull down resistor. For TXDIS: $I_{IH} = 150\mu\text{A}$ Maximum. $I_{IL} = 0.5\mu\text{A}$ Minimum.

Limiting Amplifier Electrical Characteristics

$V_{CC} = 3.3V \pm 10\%$, $T_A = -40^\circ C$ to $+85^\circ C$. Typical values at $V_{CC} = 3.3V$, $T_A = 25^\circ C$; $R_{Load} = 50\Omega$ to V_{CC} ;

Symbol	Parameter	Condition	Min	Typ	Max	Units
LOSLVL	LOSLVL Voltage		$V_{CC}-1.3$		V_{CC}	V
V_{OH}	RXOUT+, RXOUT- High Voltage		$V_{CC}-0.020$	$V_{CC}-0.005$	V_{CC}	V
V_{OL}	RXOUT+, RXOUT- Low Voltage		$V_{CC}-0.475$	$V_{CC}-0.400$	$V_{CC}-0.350$	V
Z_0	Single-Ended Output Impedance		40	50	60	Ω
Z_I	Single-Ended Input Impedance		40	50	60	Ω
t_r, t_f	Output Rise/Fall Time (20% to 80%)	Note 1		60	120	ps
t_{JITTER}	Deterministic Random	Note 2 Note 3		10 1		ps ps
$V_{ID_2.5G}$	Differential Input Voltage Swing	Note 7. See Fig #1.	10		1800	mV _{PP}
$V_{ID_3.2G}$	Differential Input Voltage Swing	Note 7. See Fig #1.	10		1800	mV _{PP}
$V_{ID_4.25G}$	Differential Input Voltage Swing	Note 7. See Fig #1.	15		1800	mV _{PP}
V_{OD}	Differential Output Voltage Swing	Note 1	600	800	950	mV _{PP}
T_{OFF}	LOS Release Time	Note 6		2	10	μ S
T_{ON}	LOS Assert Time	Note 6		2	10	μ S
LOS_{AL}	Low LOS Assert Level	$R_{LOSLVL} = 15k\Omega$, Note 4		8		mV _{PP}
LOS_{DL}	Low LOS De-assert Level	$R_{LOSLVL} = 15k\Omega$, Note 4		13		mV _{PP}
HYS_L	Low LOS Hysteresis	$R_{LOSLVL} = 15k\Omega$, Note 5	2	3.5	6	dB
LOS_{AM}	Medium LOS Assert Level	$R_{LOSLVL} = 5k\Omega$, Note 4	12	15		mV _{PP}
LOS_{DM}	Medium LOS De-assert Level	$R_{LOSLVL} = 5k\Omega$, Note 4		24	33	mV _{PP}
HYS_M	Medium LOS Hysteresis	$R_{LOSLVL} = 5k\Omega$, Note 5	2	3.7	6	dB
LOS_{AH}	High LOS Assert Level	$R_{LOSLVL} = 100\Omega$, Note 4	34	40		mV _{PP}
LOS_{DH}	High LOS De-assert Level	$R_{LOSLVL} = 100\Omega$, Note 4		65	83	mV _{PP}
HYS_H	High LOS Hysteresis	$R_{LOSLVL} = 100\Omega$, Note 5	2	4	6	dB
$A_{V(DIFF)}$	Differential Voltage Gain			38		dB
S_{21}	Single-Ended Small-Signal Gain		26	32		dB

Notes:

1. Amplifier in limiting mode. Input is a 200MHz square wave.
2. Deterministic jitter measured using 4.25Gbps K28.5 pattern, $V_{ID} = 60mV_{PP}$.
3. Random jitter measured using 4.25Gbps K28.7 pattern, $V_{ID} = 60mV_{PP}$.
4. See "Typical Operating Characteristics" for a graph showing how to choose a particular R_{LOSLVL} for a particular LOS assert and its associated de-assert amplitude.
5. This specification defines electrical hysteresis as $20\log(\text{LOS De-Assert}/\text{LOS Assert})$. The ratio between optical hysteresis and electrical hysteresis is found to vary between 1.5 and 2 depending upon the level of received optical power and ROSA characteristics. Based on that ratio, the optical hysteresis corresponding to the electrical hysteresis range 2dB-6 dB, shown in the AC characteristics table, will be 1dB-3dB Optical Hysteresis.
6. In real world applications, the LOS Release/Assert time can be strongly influenced by the RC time constant of the AC-coupling cap and the 50 Ω input termination. To keep this time low, use a decoupling cap with the lowest value that is allowed by the data rate and the number of consecutive identical bits in the application (typical values are in the range of 0.001 μ F to 1.0 μ F).
7. Input swing required to achieve 30% mask margin with PRBS 2⁷ pattern at specified data rate. See Fig #1 for differential and single-ended swing definitions.

Transmitter – Laser Diode Driver Typical Operating Characteristics

Driver Typical Functional Characteristics

$V_{CC} = 3.3V \pm 10\%$; $T_A = -40^{\circ}C$ to $+85^{\circ}C$, typical values at $V_{CC} = 3.3V$, $T_A = 25^{\circ}C$; $R_{Load} = 25\Omega$ to V_{CC} ;

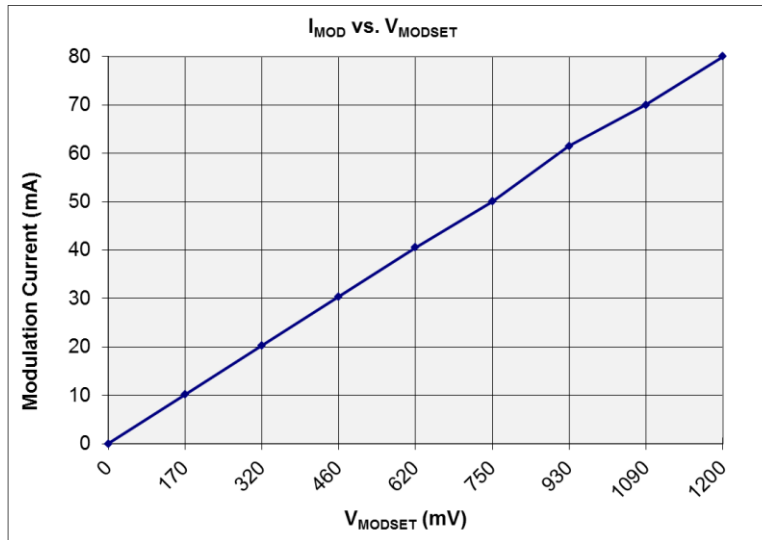

Electrical Eye Diagram @ 2.5Gbps
PRBS 2²³, 25Ω load, 40 mA
Modulation

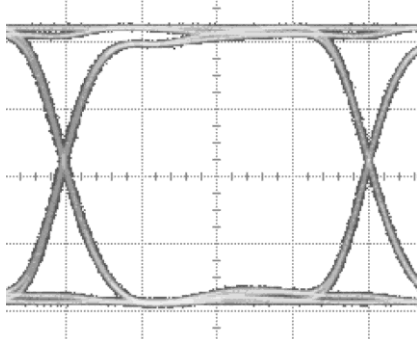

TIME (100 ps /div)

Electrical Eye Diagram @ 4.25Gbps
PRBS 2²³, 25Ω load, 40 mA
Modulation

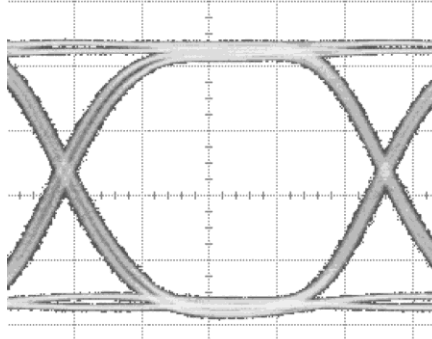

TIME (50 ps /div)

Optical Eye Diagram @ 2.5Gbps
(STM16/OC48)
ER=11 dB, mask margin = 32%

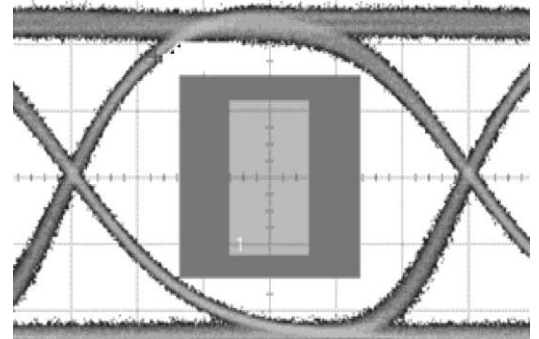

TIME (67 ps/div)

Receiver – Limiting Post Amplifier Typical Operating Characteristics

$V_{CC} = 3.3 \pm 10\%$; $T_A = -40^\circ\text{C}$ to $+85^\circ\text{C}$, typical values at $V_{CC} = 3.3\text{V}$, $T_A = 25^\circ\text{C}$; $R_{Load} = 50\Omega$ to V_{CC} ;

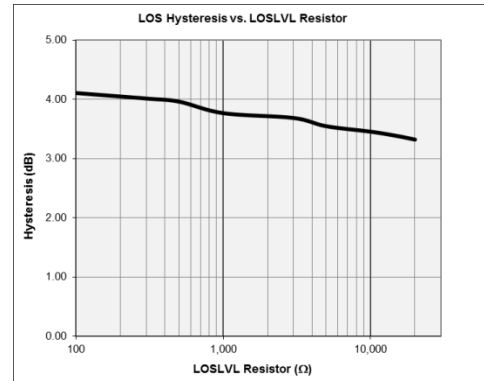
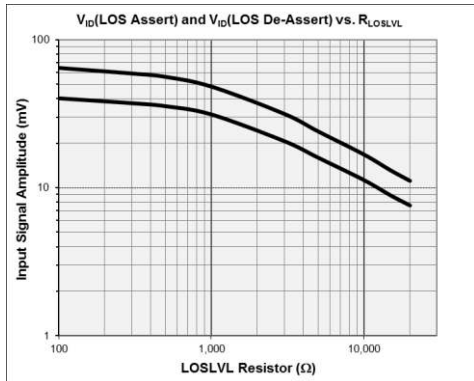

Eye Diagram @ 2.5Gbps with $V_{in}=10\text{mVpp}$

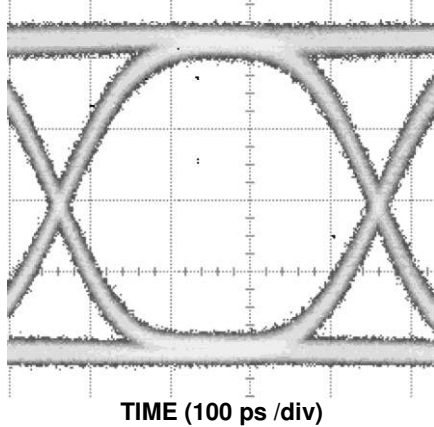

Eye Diagram @ 4.25Gbps with $V_{in}=10\text{mVpp}$

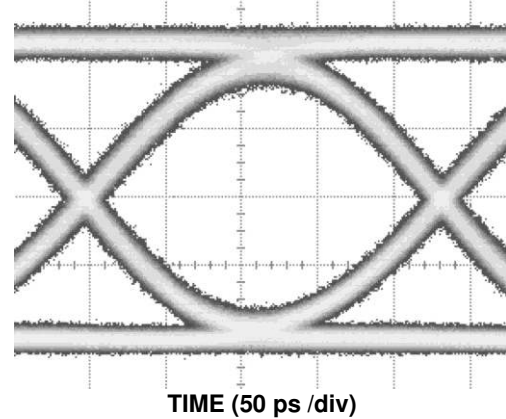

Eye Diagram @ 2.5Gbps with $V_{in}=5\text{mVpp}$

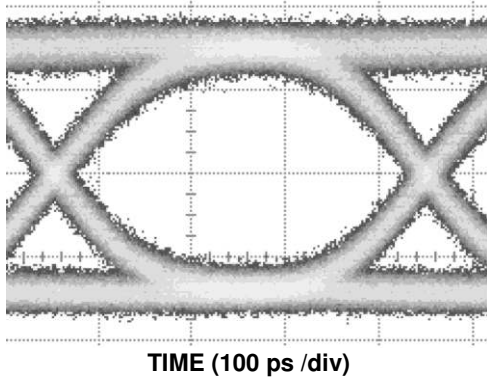

Eye Diagram @ 4.25Gbps with $V_{in}=5\text{mVpp}$

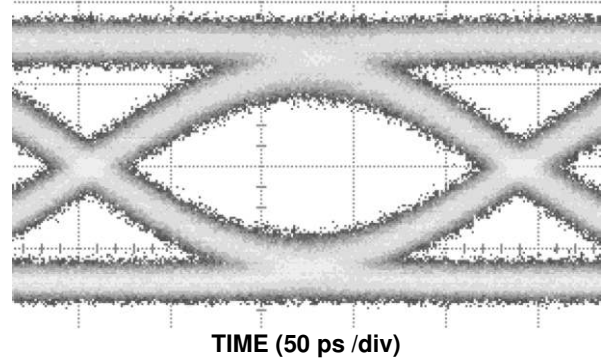

Transceiver Functional Block Diagram

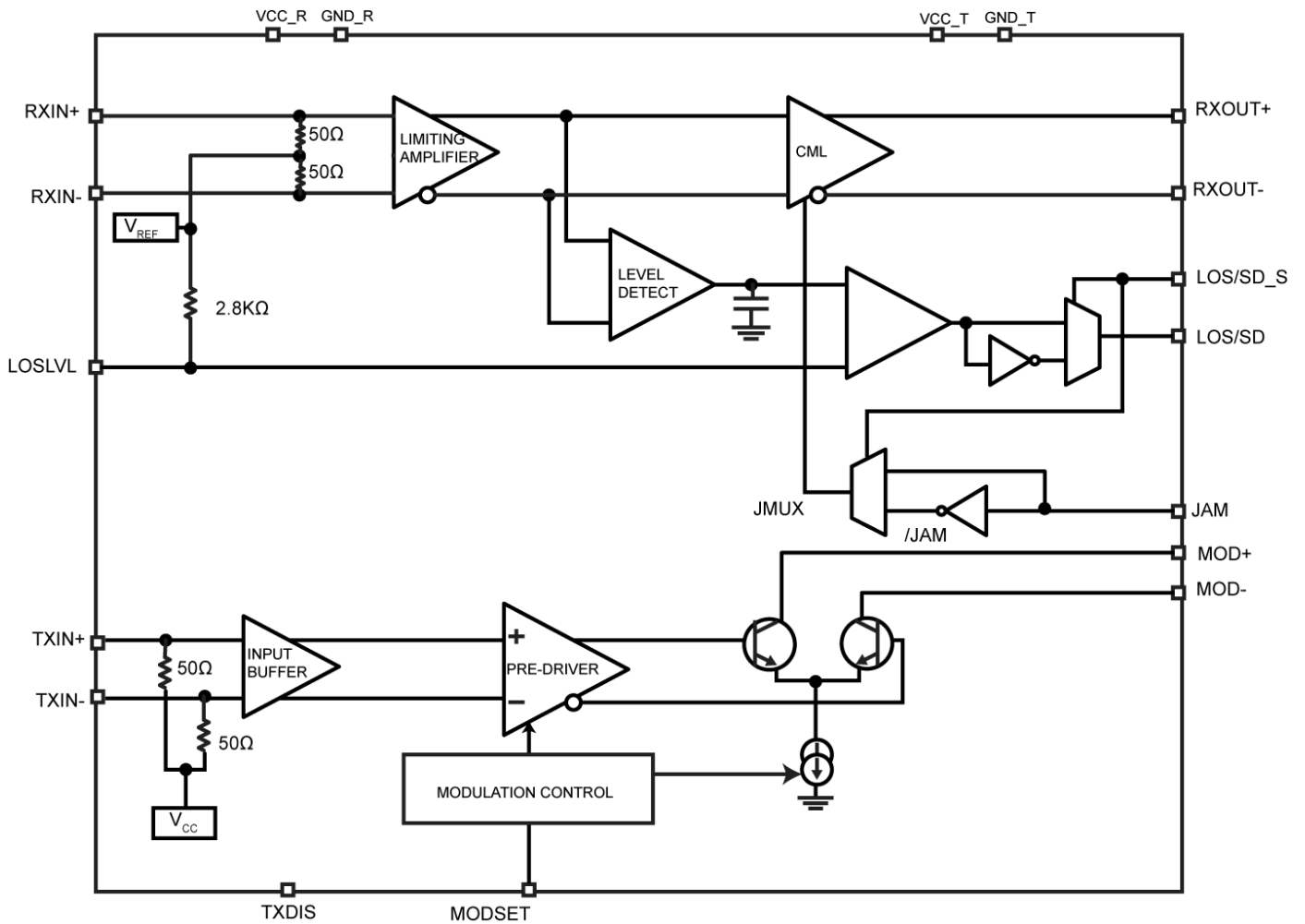

Functional Description

Transmitter - Laser Diode Driver

The laser driver consists of three stages which include the input buffer stage, a pre-driver stage where the modulation current is set, and the output driver stage.

Input Buffer

The input stage is internally terminated to V_{CC} with 50 Ω impedances. The input signals should be routed using 50 Ω transmission lines and terminated with 50 Ω impedances at the load.

Pre-Driver / Modulation Control

This stage is used to control the modulation current for the laser driver when an analog voltage between 0V to 1.2V is applied at the MODSET pin.

Output Driver

The output stage is an open-collector differential pair capable of driving modulation currents up to 60mA. It may be used single-ended or differentially. Specific care must be taken to ensure that outputs are terminated correctly for either mode of operation.

Figure 2 and 3 show input and output stages of the driver.

Receiver - Post Amplifier

The post amplifier detects and amplifies signals with data rates from 155Mbps and up to 4.25Gbps with amplitudes as low as 10mV_{PP}.

To reduce the noise at the output of the post amplifier when the input signal is absent or lower than the minimum detectable level set by LOSLVL, a JAM pin is provided, which can be connected to LOS/SD output to turn off the output buffer when LOS is asserted or SD is de-asserted.

Input Amplifier/Buffer

Figure 4 shows a simplified schematic of the input stage. The high-sensitivity of the input amplifier allows signals as small as 10mV_{PP} to be detected and amplified. The input amplifier allows input signals as large as 1800mV_{PP}.

Figure 1 shows the allowed input voltage swing. Small input signals below typically 12mV_{PP} are linearly amplified with a typical 38dB differential voltage gain. For input signals larger than 12mV_{PP}, the output signal is limited to typically 800mV_{PP}.

Output Buffer

The post amplifier CML output buffer is designed to drive 50 Ω lines and is internally terminated with 50 Ω

to V_{CC} . Figure 5 shows a simplified schematic of the output stage which can be either AC-coupled (as shown) or DC-coupled.

Loss-of-Signal

The post amplifier generates a selectable chatter-free loss-of-signal (LOS) or signal detect (SD) open-collector TTL output as shown in Figure 6. LOS/SD is used to determine that the input amplitude is too small to be considered as a valid input.

When the LOS function is selected (LOS/SD_S=0), LOS/SD asserts high if the input amplitude falls below the threshold set by LOSLVL and de-asserts low otherwise.

If the SD function is selected (LOS/SD_S=1), LOS/SD asserts low if the input amplitude falls below the threshold set by LOSLVL and de-asserts high otherwise.

LOS/SD can be fed back to the JAM input to maintain output stability under a loss of signal condition. Jam de-asserts low the true output signal without removing the input signals.

Typically, 3dB LOS hysteresis is provided to prevent chattering.

Loss/Signal Detect Selection

A pin (LOS/SD_S) is provided to select between LOS (set to LOW) or SD (set to HIGH) function. It also controls the internal circuitry of JAM input to follow LOS/SD selection.

Loss-of-Signal-Level Set

A programmable LOS/SD level set pin (LOSLVL) sets the threshold of the input amplitude detection. Connecting an external resistor between V_{CC} and LOSLVL sets the voltage at LOSLVL. This voltage ranges from V_{CC} to $V_{CC} - 1.3V$. The external resistor creates a voltage divider between V_{CC} and $V_{CC} - 1.3V$, as shown on Figure 7.

Hysteresis

The post amplifier provides typically 3.5dB LOS electrical hysteresis, which is defined as $20\log(V_{IN_LOS_Assert} / V_{IN_LOS_De_Assert})$. Since the relationship between the voltage out of the ROSA to optical power at its input is linear, the optical hysteresis will be typically half of the electrical hysteresis reported in the datasheet, but in practice, the ratio between electrical and optical hysteresis is found to be within the range 1.5 to 1.8. Thus, 3.5dB electrical hysteresis will correspond to an optical hysteresis within the range 1.6dB to 2dB.

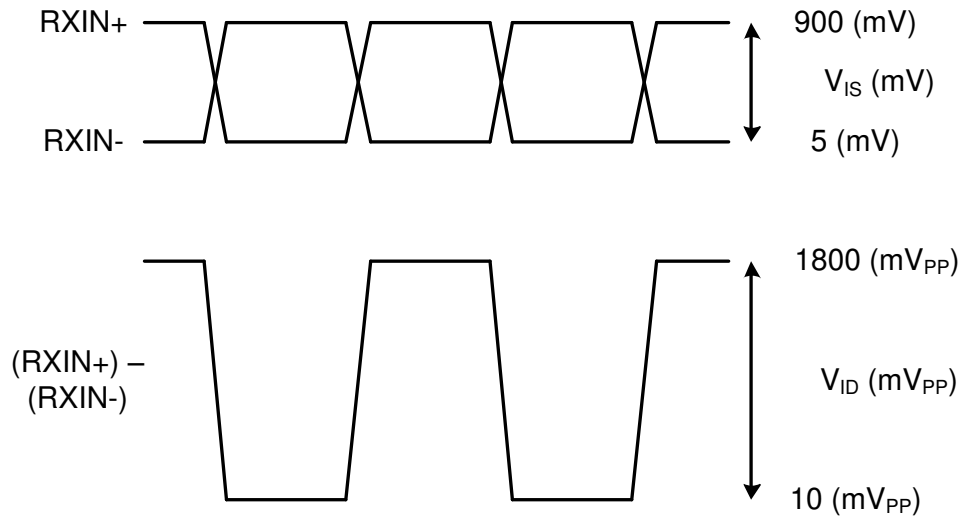

Figure 1. Transceiver V_{IS} and V_{ID} Definition

Input and Output Stages

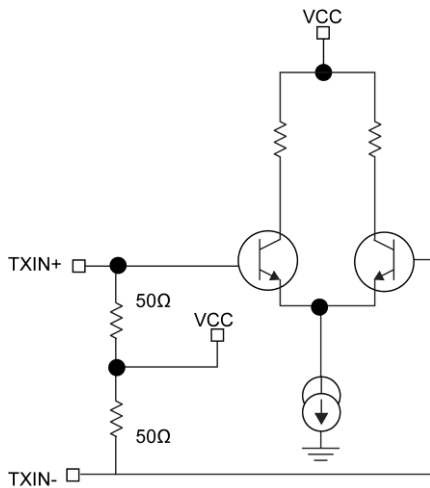

Figure 2. Laser Diode Driver Input Stage

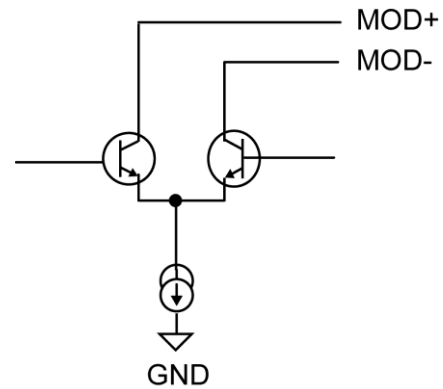

Figure 3. Simplified Laser Diode Driver Output Stage

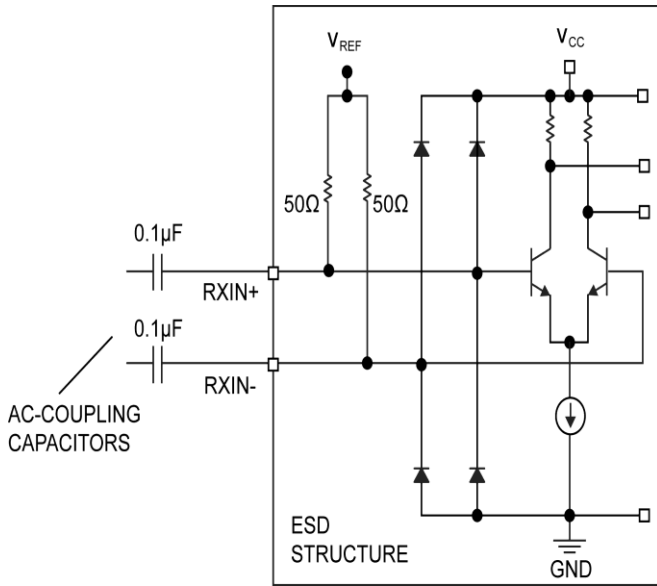

Figure 4. Receiver – Post Amplifier Input Structure

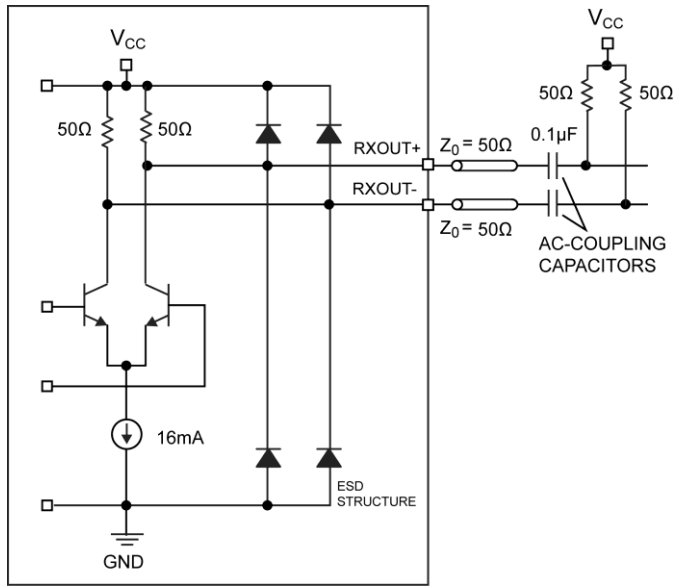

Figure 5. Receiver – Post Amplifier Output Structure

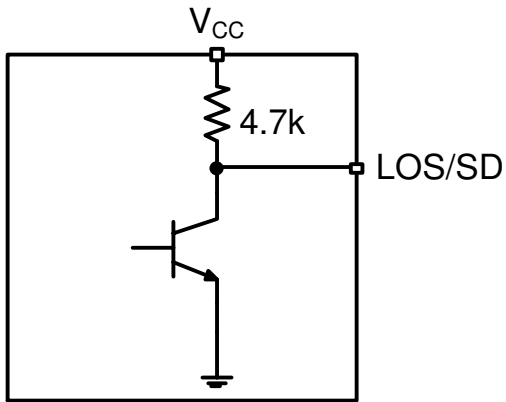

Figure 6. Receiver LOS/SD Output Structure

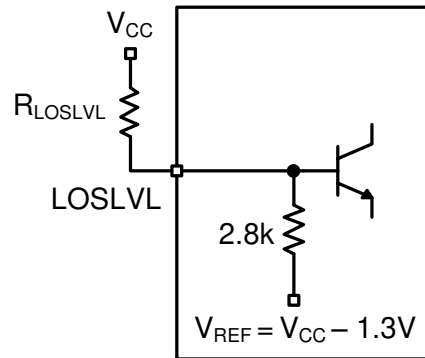

Figure 7. Receiver LOSLVL Setting Circuit

Note: Recommended value for R_{LOSLVL} is 15kΩ or less.

Application Hints

The typical applications drawing on the front page shows how to connect the driver to the laser in a single-ended configuration where the MOD- signal is disconnected from the laser anode and pulled up to V_{CC} with a resistor equal to the equivalent resistor of the load on MOD+, damping resistor plus the laser equivalent resistance.

Differential drive improves transition time and laser response. Driving the laser differentially will also minimize the cross talk with the rest of the circuitry on the board and especially the receiver.

Referring to Figure 8, the modulation current out of the driver is split between the pull-up network and the laser. If, for example, the total pull-up resistor is twice the sum of the damping resistor and laser equivalent series resistance, only two thirds (2/3) of the modulation current will be used by the laser.

To keep most of the modulation current going through the laser, it is necessary that the total pull-up resistors are high as possible. One solution consists of using a combination of resistor and inductor as shown in Figure 8 below. In this case, the headroom of the driver is $V_{CC} - R1 * \alpha_{I_{mod}}$, where $\alpha_{I_{mod}}$ is the portion of the modulation current that goes through the pull-up network.

The coupling capacitor creates a low-frequency cut-off in the circuit, and its value must be chosen to accommodate the lowest and the highest data rates. If the value of the cap is too high, it will degrade the performance at higher data rates. If its value is too small, it will not be able to hold a constant charge between the first bit and the last bit of a long string of identical bits in a low data rate application. Both cases lead to higher pattern-dependent jitter in the transmitter signal. 0.01-to-0.1 μ F is found to be good range for all applications from 155Mbps to 4.25Gbps

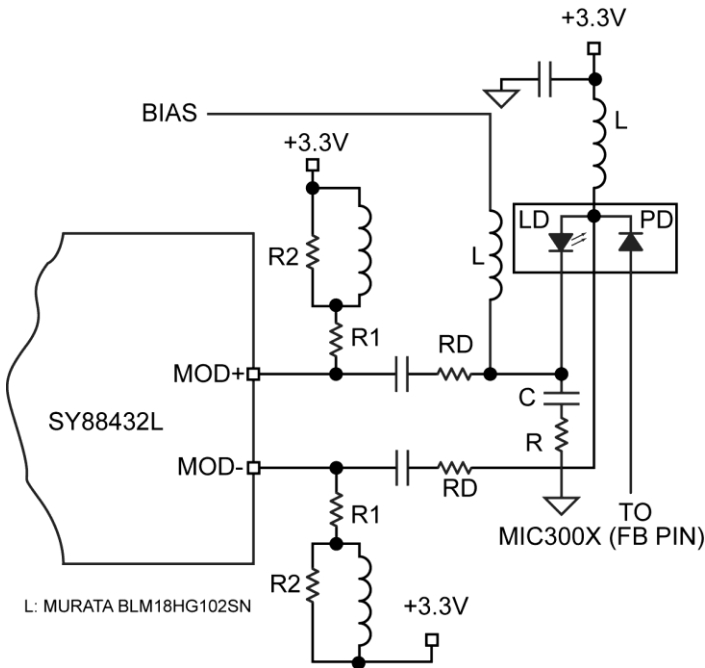
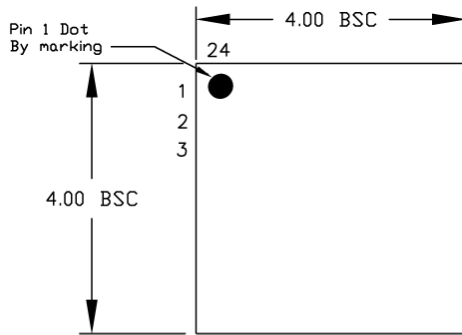
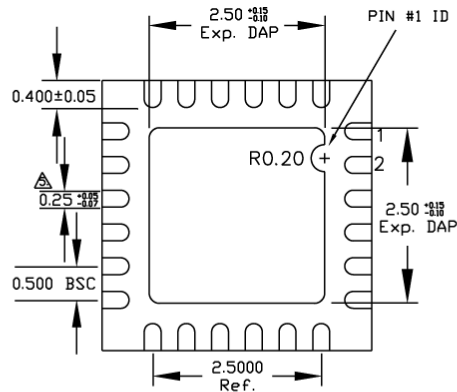

Figure 8. Transceiver Laser Driver Stage AC-coupled Differential Interface Network

Package Information



TOP VIEW



BOTTOM VIEW

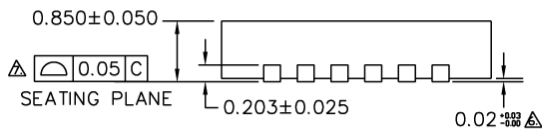

SIDE VIEW

NOTE:

1. ALL DIMENSIONS ARE IN MILLIMETERS.
 2. MAX. PACKAGE WARPAGE IS 0.05 mm.
 3. MAXIMUM ALLOWABLE BURRS IS 0.076 mm IN ALL DIRECTIONS.
 4. PIN #1 ID ON TOP WILL BE LASER/INK MARKED. DIMENSION APPLIES TO METALIZED TERMINAL AND IS MEASURED BETWEEN 0.20 AND 0.25 mm FROM TERMINAL TIP.
- APPLIED ONLY FOR TERMINALS.
 - APPLIED FOR EXPOSED PAD AND TERMINALS.

24 lead QFN (4 x 4 mm)

MICREL, INC. 2180 FORTUNE DRIVE SAN JOSE, CA 95131 USA
 TEL +1 (408) 944-0800 FAX +1 (408) 474-1000 WEB <http://www.micrel.com>

Micrel makes no representations or warranties with respect to the accuracy or completeness of the information furnished in this data sheet. This information is not intended as a warranty and Micrel does not assume responsibility for its use. Micrel reserves the right to change circuitry, specifications and descriptions at any time without notice. No license, whether express, implied, arising by estoppel or otherwise, to any intellectual property rights is granted by this document. Except as provided in Micrel's terms and conditions of sale for such products, Micrel assumes no liability whatsoever, and Micrel disclaims any express or implied warranty relating to the sale and/or use of Micrel products including liability or warranties relating to fitness for a particular purpose, merchantability, or infringement of any patent, copyright or other intellectual property right.

Micrel Products are not designed or authorized for use as components in life support appliances, devices or systems where malfunction of a product can reasonably be expected to result in personal injury. Life support devices or systems are devices or systems that (a) are intended for surgical implant into the body or (b) support or sustain life, and whose failure to perform can be reasonably expected to result in a significant injury to the user. A Purchaser's use or sale of Micrel Products for use in life support appliances, devices or systems is a Purchaser's own risk and Purchaser agrees to fully indemnify Micrel for any damages resulting from such use or sale.