

- 1
- 2
- 3
- 4
- 5
- 6
- 7
- 8
- 9
- 10
- 11
- 12
- 13
- 14
- 15
- RH

STANDARD EXECUTIONS

- **TLX.Z-A:** Zinc-plated steel lever body, bracket and torsion springs. Without locking spring cotter pins.
- **TLX.Z-B:** Zinc-plated steel lever body, bracket and torsion springs. With locking spring cotter pins.
- **TLX.SST-A:** lever body, bracket and torsion springs in AISI 304 stainless steel. Without locking spring cotter pins.
- **TLX.SST-B:** lever body, bracket and torsion springs in AISI 304 stainless steel. With locking spring cotter pins.

LOCKING SPRING COTTER PINS.

Stainless steel.

FEATURES AND APPLICATIONS

TLX hook clamps have got an internal spring mechanism that maintains both the control lever and the locking hook in the open position, allowing an easy operation.

Once the dead center has been overcome, the elasticity of the sheet metal parts causes the locking of the clamp.

For a correct functioning of the hook clamp, it is necessary to keep the hole centre distance f , by means of low flat head screws or rivets.

The TLX-B version allows the prevention of the accidental opening of the closure by means of a spring cotter pin inserted into the $d1$ hole. The maximum load values indicated in the table are the result of laboratory tests obtained in a state of static stress. Such values have to be considered as purely indicative and must be verified under the specific conditions of use.

Fig.1: in the unlocked position, the hook clamp is held in the position indicated by two internal torsion springs.

Fig.2: by lifting the lever, the locking hook is moved towards the stop.

Fig.3: by pressing the lever, the locking hook engages with the stop until it reaches the locking position.

Fig.4: to unlock, simply lift the locking lever.

All these engaging and disengaging operations of the hook clamp can be done by using one hand only, since in its movement the locking hook follows the lever.

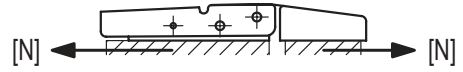

Fig.1

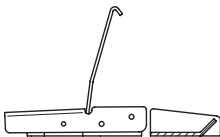

Fig.2

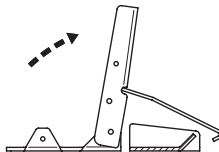

Fig.3

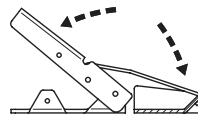
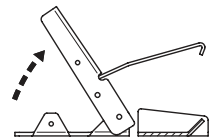
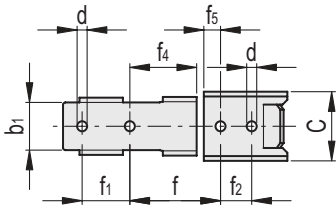

Fig.4



TLX.Z-A
TLX.SST-A
(C = 15/20/29)



TLX.Z-A
TLX.SST-A
(C = 40)

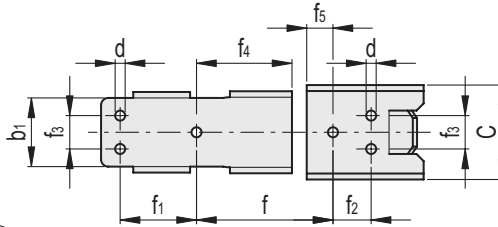

TLX.Z-B
TLX.SST-B
(C = 15/20/29/40)

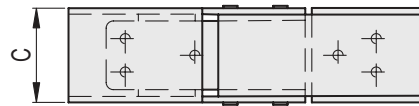
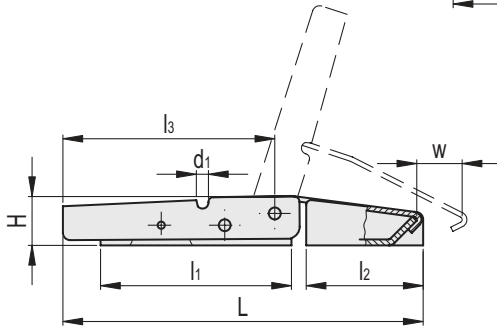
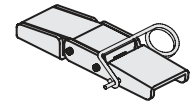

Conversion Table
1 mm = 0.039 inch

TLX.Z-A

METRIC

Code	Description	L	C	H	d	d1	b1	l1	l2	l3	f	f1	f2	f3	f4	f5	w	Max. working load [N]	⚖️
420301	TLX.Z-15/53-A+R	53	15	8	3.4	1.4	9.5	25	17	31.5	13.5+0.3	9.5	6.2	-	8.5	3	11	100	16
420311	TLX.Z-20/76-A+R	76	20	10	3.4	1.8	13	34	25	44	29+0.5	8	8	-	22	4	9	300	35
420321	TLX.Z-29/111-A+R	111	29	15	4.2	2.5	20	56	35	67	38.8+0.5	20	13	-	28	7	11	600	123
420331	TLX.Z-40/152-A+R	152	40	20	4.2	3	29	80	49	89	57.3+0.5	32	16	14	40	11	19	1200	289

TLX.Z-B

METRIC

Code	Description	L	C	H	d	d1	b1	l1	l2	l3	f	f1	f2	f3	f4	f5	w	Max. working load [N]	⚖️
420302	TLX.Z-15/53-B+R	53	15	8	3.4	1.4	9.5	25	17	31.5	13.5+0.3	9.5	6.2	-	8.5	3	11	100	17
420312	TLX.Z-20/76-B+R	76	20	10	3.4	1.8	13	34	25	44	29+0.5	8	8	-	22	4	9	300	36
420322	TLX.Z-29/111-B+R	111	29	15	4.2	2.5	20	56	35	67	38.8+0.5	20	13	-	28	7	11	600	128
420332	TLX.Z-40/152-B+R	152	40	20	4.2	3	29	80	49	89	57.3+0.5	32	16	14	40	11	19	1200	294

TLX.SST-A

INOX STAINLESS STEEL METRIC

Code	Description	L	C	H	d	d1	b1	l1	l2	l3	f	f1	f2	f3	f4	f5	w	Max. working load [N]	⚖️
420351	TLX.SST-15/53-A+R	53	15	8	3.4	1.4	9.5	25	17	31.5	13.5+0.3	9.5	6.2	-	8.5	3	11	100	20
420361	TLX.SST-20/76-A+R	76	20	10	3.4	1.8	13	34	25	44	29+0.5	8	8	-	22	4	9	300	37
420371	TLX.SST-29/111-A+R	111	29	15	4.2	2.5	20	56	35	67	38.8+0.5	20	13	-	28	7	11	600	117
420381	TLX.SST-40/152-A+R	152	40	20	4.2	3	29	80	49	89	57.3+0.5	32	16	14	40	11	19	1200	280

TLX.SST-B

INOX STAINLESS STEEL METRIC

Code	Description	L	C	H	d	d1	b1	l1	l2	l3	f	f1	f2	f3	f4	f5	w	Max. working load [N]	⚖️
420352	TLX.SST-15/53-B+R	53	15	8	3.4	1.4	9.5	25	17	31.5	13.5+0.3	9.5	6.2	-	8.5	3	11	100	17
420362	TLX.SST-20/76-B+R	76	20	10	3.4	1.8	13	34	25	44	29+0.5	8	8	-	22	4	9	300	38
420372	TLX.SST-29/111-B+R	111	29	15	4.2	2.5	20	56	35	67	38.8+0.5	20	13	-	28	7	11	600	122
420382	TLX.SST-40/152-B+R	152	40	20	4.2	3	29	80	49	89	57.3+0.5	32	16	14	40	11	19	1200	286



Latches