

THIS DRAWING IS UNPUBLISHED. RELEASED FOR PUBLICATION  
 © COPYRIGHT 20 ALL RIGHTS RESERVED.

LOC	DIST	REVISIONS			
P	LTR	DESCRIPTION	DATE	DWN	APVD
AI	-				
	C2	2-1987143-3 ADDED	30SEP2008	DZ	HB
	D4	OBSOLETE 5-1987143-1	13JAN2020	MB	PKS

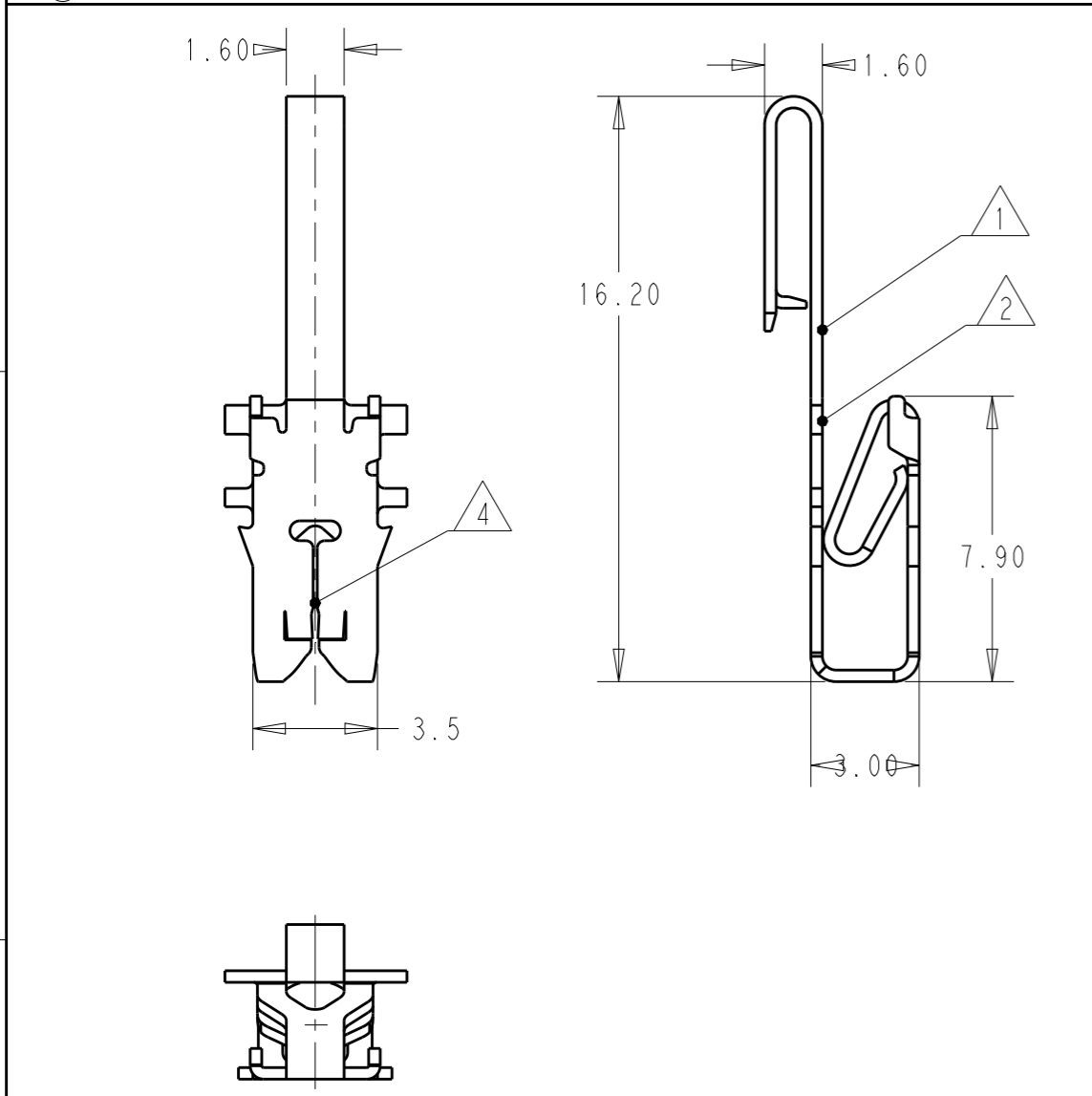

- 8 Zwei Draehete gleichen Durchmessers  
TWO WIRES OF SAME DIAMETER
- 7 Reeling Richtung  
REELING DIRECTION
- 6 Materialdicke 0.32±0.02  
STOCK THICKNESS 0.32±0.02
- 5 Werkzeugvorschub : 5mm  
DIE FEED : 5mm
- 4 Schlitz geeignet fuer Kupferlackdraht  
einfach oder doppelt (gemaeß Tabelle)  
SLOT ACCEPTS: SINGLE OR DOUBLE MAGNET WIRE  
(SEE TABLE FOR SIZE)
- 3 Kontaktkammer nach  
Zeichnung Nr.411-18517  
CONTACT CAVITY ACCORDING  
DRAWING No. 411-18517
- 2 TE Markenzeichen  
TE TRADEMARK
- 1 Kennziffer fuer Lackdrahtbereich  
IDENTIFICATION NO. FOR MAGNET WIRE RANGE

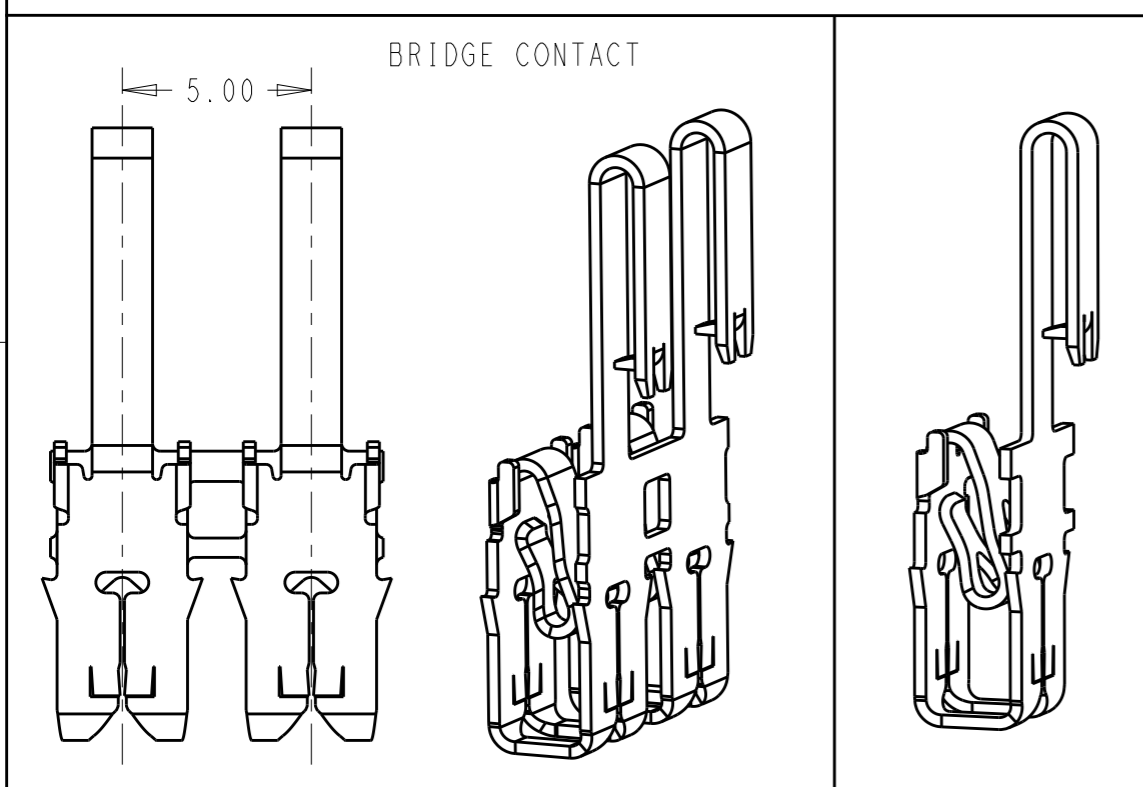
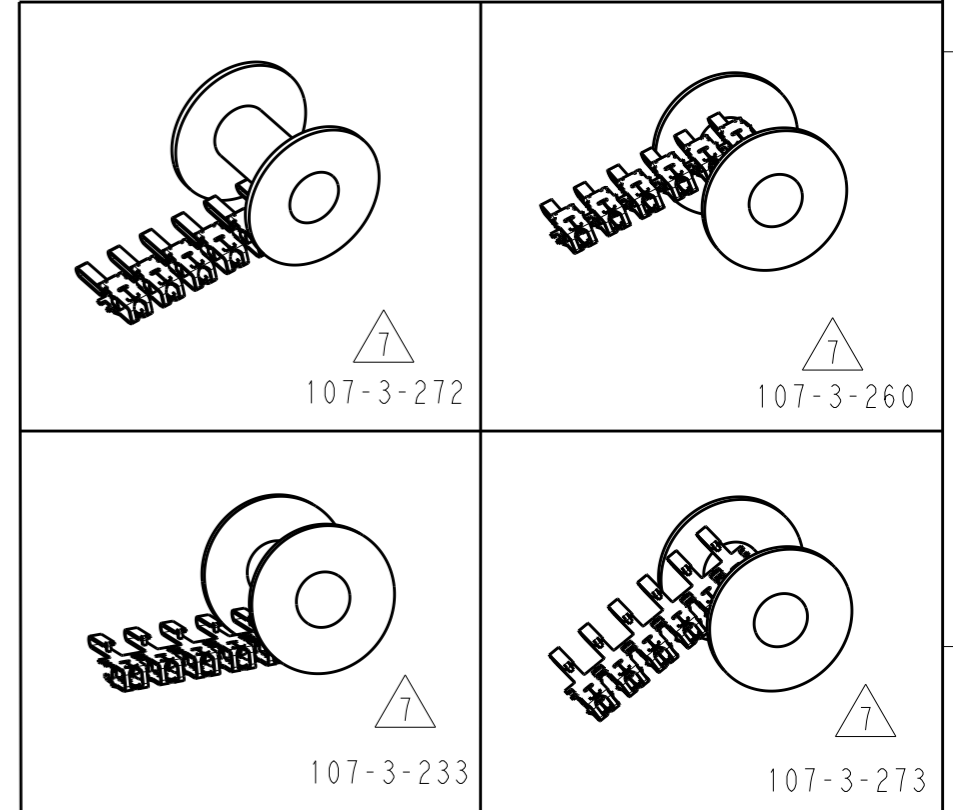

ID. MARK	DOUBLE W. WIRE RANGE	SINGLE W. WIRE RANGE	REELING	MATERIAL	PRODUCED FROM	FINISH	PART NO	Par Rev
4	0.180 to 0.265	0.180 to 0.265	107-3-233	CuNiSi	Pre-tin		6-1987143-2	D
					BLANK		6-1987143-1	D
				7 CuZn	Pre-tin		5-1987143-2	D
					BLANK	OBSOLETE	<del>5-1987143-1</del>	D
	107-3-272	8	CuNiSi	2-1987143-1 posttinned 2-6µm. Spec. 112-16-3	OBSOLETE	<del>2-1987143-3</del>	D	
				Pre-tin		2-1987143-2	D	
				BLANK		2-1987143-1	D	
			7 CuZn	Pre-tin	OBSOLETE	<del>1-1987143-2</del>	D	
			BLANK		1-1987143-1	D		

THIS DRAWING IS A CONTROLLED DOCUMENT.

DWN 16-May-07 Praveen K  
 CHK 10-July-07 M. Boeffert  
 APVD 10-July-07 T. Gerlach

**STE** TE Connectivity

NAME: MAG-MATE EDGE-LEAF CONTACT

PRODUCT SPEC: -  
 APPLICATION SPEC: -  
 WEIGHT: -

MATERIAL: SEE TABLE FINISH: SEE TABLE

SIZE: A3 CAGE CODE: 00779 DRAWING NO: 1987143 RESTRICTED TO: -

CUSTOMER DRAWING SCALE: 1:1 SHEET 1 OF 1 REV: D4