

PART NUMBER	REV	FIRST USED
567463-1	C	854400-1
567463-2	C	565435-5

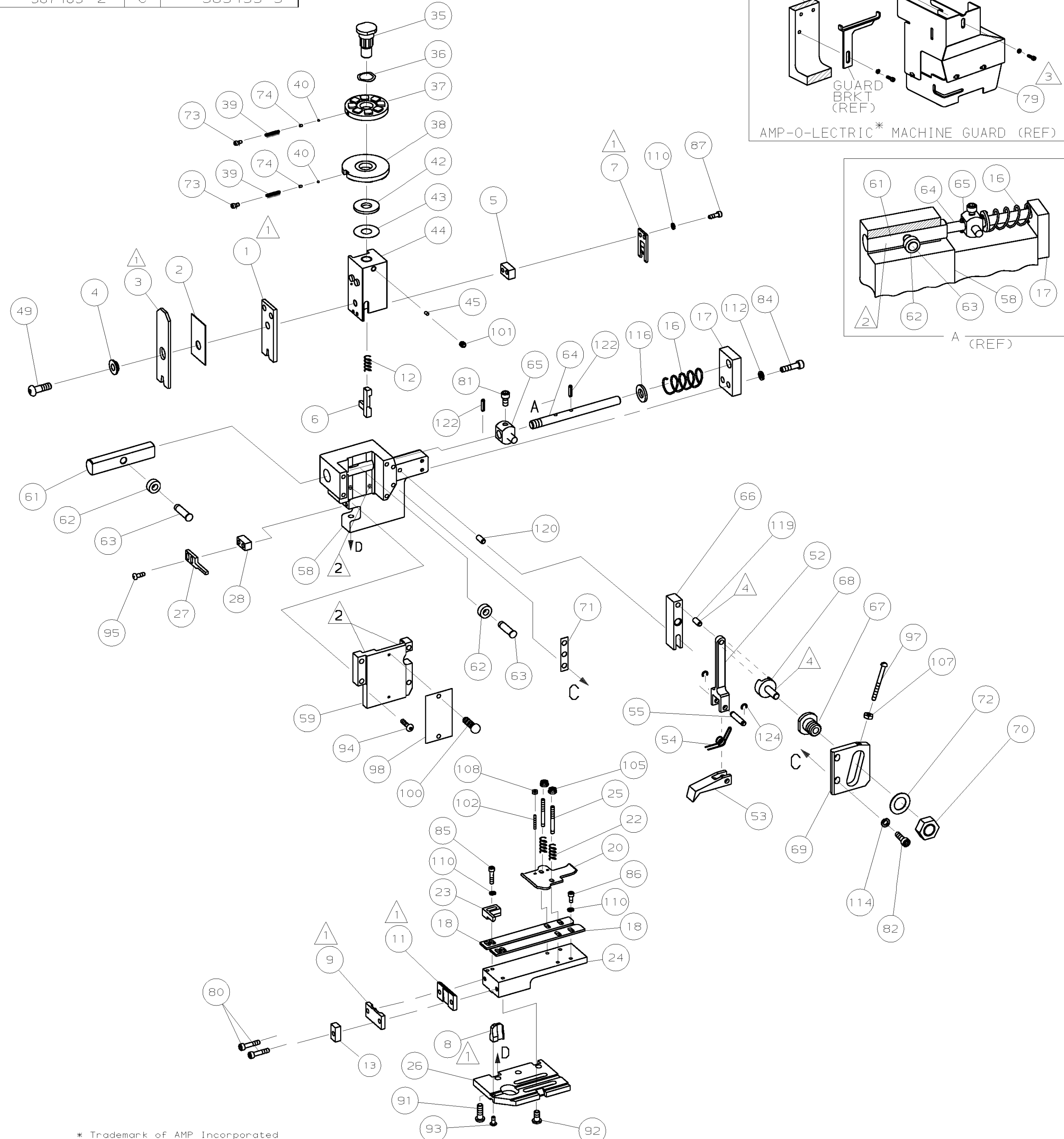
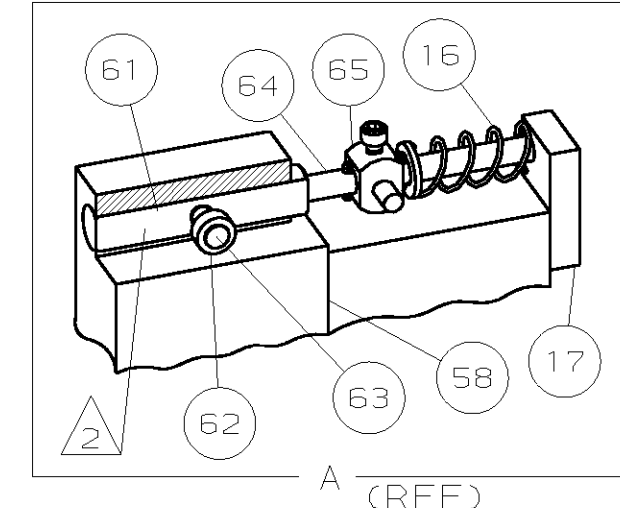
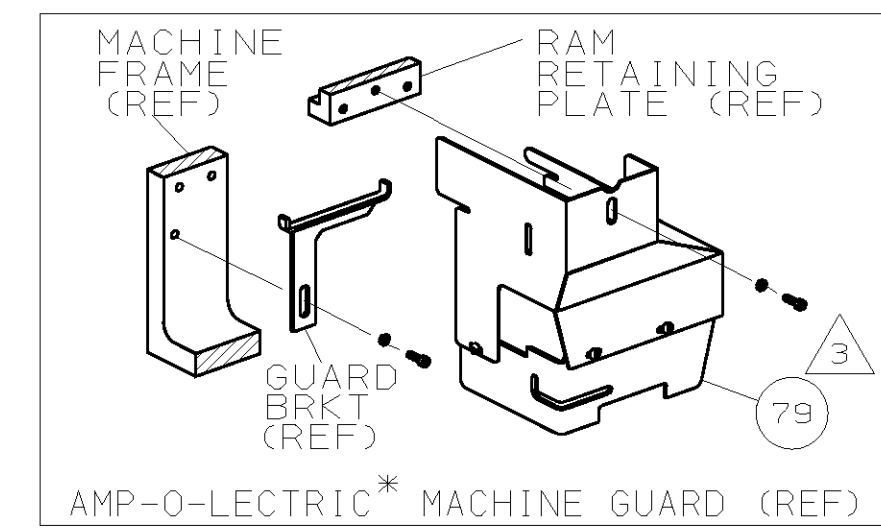

TERMINAL NAME:
2.36 (.093) DIA PIN RECEPT W/LANCE

	172792-1
	172792-2

CRIMPING DATA

PAD LTR	CRIMP HEIGHT	WIRE SIZE
A	.047 ±.002	18
B	.043 ±.002	20
C	.039 ±.002	22
D	NOT USED	

CRIMP	SIZE	TYPE	RANGE
WIRE	.070	F	22-18
INSUL	.140	F	.047-.110

FEED	APPL INST	SET UP GAGE	LAYOUT
.650	A1 8039	458638-1	L1462

WIRE STRIP LENGTH -

	LEADMAKER	MECH-POST FEED
-1		
	AMP-O-LECTRIC	MECH-PRE FEED
-2		

REF	REF	-	A	21045-3	RING, RET "C" (Ø.187) FD PIN	125
						124
REF	REF	-	A	5-21028-1	PIN, STD SPRING (Ø.12) FD ADJ ROD	123
						122
REF	REF	-	A	1-21030-7	PIN, DOWEL (Ø.187x1.50) H56	120
REF	REF	-	A	1-21030-1	PIN, DOWEL (Ø.187x.50) LEVER	119
						118
						117
REF	REF	-	A	21899-4	WASHER, FLAT (Ø5/16) SCR ADJ	116
						115
REF	REF	-	A	21024-5	WASHER, LOCK (NO.10) FD ADJ PL	114
						113
REF	REF	-	A	21024-5	WASHER, LOCK (NO.10) FD ROD GDE	112
						111
7	7	-	A	21024-4	WASHER, LOCK (NO.8) SHEAR BL	110
						109
2	2	-	A	21018-4	NUT, HEX (4-40) DRAG	108
REF	REF	-	A	21018-5	NUT, HEX (6-32) FD ADJ PL	107
						106
2	2	-	A	21022-2	NUT, HEX SL (8-32) DRAG STUD	105
						104
						103
2	2	-	A	4-21078-8	SKT SKT SET (4-40x.75) DRAG	102
1	1	-	A	21009-2	SCR, SKT SET (1/4-20x.25) RAM	101
2	2	-	A	21017-2	SCR, DRIVE (#2x.19) ID PLATE	100
1	1	-	A	1-21002-7	SCR, BHC (8-32x.38) CAM	99
1	1	-	B	461264-1	PLATE, IDENTIFICATION	98
REF	REF	-	A	6-23715-5	SCR, PAN HD (8-32x1.50) FEED ADJ	97
						96
2	2	-	A	2-21002-2	SCR, BHC (8-32x.50) STRIPPER	95
REF	REF	-	A	2-21002-9	SCR, BHC (10-32x.75) H56 CAP	94
1	1	-	A	22733-8	SCR, BHC (8-32x.38 LW) ANVIL	93
4	4	-	A	3-21002-3	SCR, BHC (1/4-20x.50) ST 6D PL	92
REF	REF	-	A	2-22733-8	SCR, BHC (1/4-20x.62) BASE PL	91
						90
						89
						88
2	2	-	A	2-21000-6	SCR, SHC (8-32x.38) SLUG BLADE	87
3	3	-	A	2-21000-5	SCR, SHC (8-32x.25) STRIP GUIDE	86
2	2	-	A	2-21000-9	SCR, SHC (8-32x.75) R STRIP GUIDE	85
REF	REF	-	A	3-21000-7	SCR, SKT CAP (10-32x.75) FD GDE	84
						83
REF	REF	-	A	3-21000-6	SCR, SKT CAP (10-32x.62) FD ADJ P	82
REF	REF	-	A	3-21000-4	SCR, SKT CAP (10-32x.38) PIVOT BL	81
2	2	-	A	2-21002-9	SCR, SKT CAP (10-32x.75) SH PL	80
REF	-	-	A	455745-1	GUARD, WINDOW	79
						78
						77
						76
						75
2	2	-	A	690603-1	SPRING, ASSIST	74
2	2	-	A	23030-1	SCR, SKT CAP (6-32x.25) CP DSC	73
REF	REF	-	A	458109-1	WASHER, FLAT (SPECIAL)	72
REF	REF	-	A	690517-1	SPACER	71

REF	REF	-	A	22594-8	NUT, HEX	70
REF	REF	-	B	240628-1	PLATE, ADJ	69
REF	REF	-	B	240626-1	SHAFT, PIVOT	68
REF	REF	-	B	240633-1	BUSHING	67
REF	REF	-	A	455680-1	LEVER, INTERMEDIATE	66
REF	REF	-	B	240629-1	BLOCK, PIVOT	65
REF	REF	-	A	240632-2	SCR, ADJ	64
REF	REF	-	B	240659-3	PIN, CAM ROLLER	63
REF	REF	-	B	240658-1	CAM, ROLLER	62
REF	REF	-	B	454398-1	ROD, FEED	61
						60
REF	REF	-	C	454220-1	CAP, RAM	59
REF	REF	-	D	453736-1	HOUSING	58
						57
						56
REF	REF	-	B	240624-1	PIN, FEED FINGER	55
REF	REF	-	B	691499-1	SPRING, FEED FINGER	54
REF	REF	-	B	240635-1	FINGER, FEED	53
REF	REF	-	B	240634-1	LEVER, TERMINAL	52
						51
						50
1	1	-	A	7-21002-9	BOLT, CRIMPER (5/16-24x1.00)	49
1	-	-	B	690602-5	CAM, PRE-FEED 1 1/8 ST	48
-	1	-	B	690501-4	CAM, POST-FEED 1 5/8 ST	47
						46
1	1	-	A	690191-1	PLUG, NYLON	45
1	1	-	C	455674-1	RAM	44
1	1	-	A	690125-1	WASHER, LAMINATED	43
1	1	-	A	690124-1	WASHER, RAM	42
						41
2	2	-	A	23241-6	BALL, STEEL	40
2	2	-	A	690170-1	SPRING, COMPRESSION	39
1	1	-	C	690142-1	DISC, INSULATION	38
1	1	-	D	5-692155-1	DISC, WIRE	37
1	1	-	A	22480-5	WASHER, SPRING	36
1	1	-	B	690212-1	POST, RAM	35
						34
						33
1	1	-	D	458980-1	APPLICATOR, BASIC (SUB ASSY)	32
						31
						30
						29
1	1	-	B	2-690451-4	SPACER, STRIPPER	28
REF	REF	-	A	240639-3	STRIPPER	27
REF	REF	-	C	455676-1	PLATE, BASE	26
2	2	-	A	22354-8	DRAG, STUD	25
1	1	-	B	458803-9	PLATE, STRIP GUIDE	24
1	1	-	C	240825-6	PLATE, STRIP HOLD DOWN	23
2	2	-	A	4-22281-1	SPRING, DRAG	22
						21
1	1	-	A	454177-1	DRAG, STOCK	20
						19
2	2	-	C	454204-1	GUIDE, STRIP (FRONT)	18
REF	REF	-	A	454178-1	GUIDE, FEED ROD	17
REF	REF	-	A	4-22284-9	SPRING, FEED RETURN	16
						15
						14
1	1	-	C	1-690481-4	SPACER, HOLD DOWN	13
1	1	-	A	23846-1	SPRING, HOLD DOWN	12
1	1	-	B	240833-3	PLATE, REAR SHEAR	11
						10
1	1	-	B	3-690482-9	PLATE, FRONT SHEAR	9
1	1	-	D	7-683452-0	ANVIL	8
1	1	-	B	690474-6	BLADE, SLUG	7
1	1	-	D	2-455892-2	HOLD DOWN, TERMINAL	6
1	1	-	C	1-240641-3	SPACER, SLUG BLADE	5
1	1	-	B	2-238009-2	SPACER, BLOCK CRIMPER	4
1	1	-	C	2-456134-3	CRIMPER, INSULATION	3
1	1	-	B	455888-6	SPACER, CRIMPER	2
1	1	-	C	1-456404-8	CRIMPER, WIRE	1

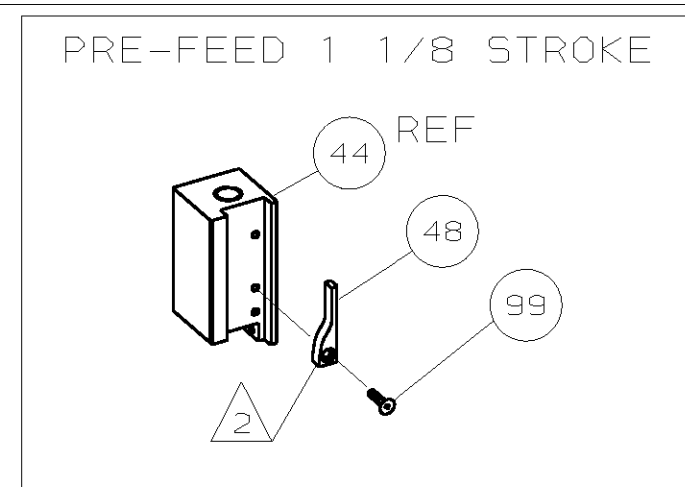
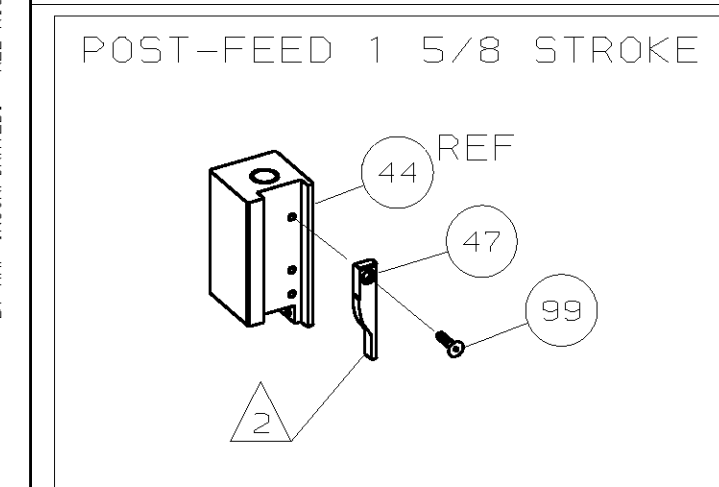

- 1 RECOMMENDED SPARE PARTS.
- 2 GREASE LIGHTLY.
- 3 GUARD MUST BE IN PLACE WHEN OPERATING APPLICATOR IN AMP-O-LECTRIC MACHINE.
- 4 LUBRICATE DAILY USING NO. 20 MACHINE OIL.
- 5. ITEMS WITH QTY OF REF SPECIFIED (EXCEPT ITEM 79) ARE USED ON ITEM 32.

LOC A
DIST 66
T TERMINATING UNIT

AMP-O-LECTRIC
K TERMINATING UNIT

DIMENSIONS IN INCHES. DO NOT SCALE PRINT.		MATERIAL		HT TR		FIN	
TOLERANCES UNLESS OTHERWISE SPECIFIED:		-		-		-	
2 PLC DEC ±		DR P.MATHIAS 7/31/92		APP 8/22/95			
3 PLC DEC ±		S. FERANTTI		S. FERANTTI			
4 PLC DEC ±		CHK 8/22/95		REL 8/31/95			
		S. FERANTTI		B. MORGAN			
REMOVE BURRS, BREAK SHARP EDGES R.015 MAX		NAME		END FEED HDM APPLICATOR		MACHINE REF	
		SCALE		DWG NO		1 OF 1	
		D		567463		REV C	