

Description

The AGQ100-48S12 is a single output DC-DC converter with standard quarter-brick outline and pin configuration. It delivers up to 8.3A output current with 12.0V output voltage. Above 92.9% efficiency and excellent thermal performance make it an ideal choice to supply power in telecom and datacom application. It can work under -40°C ~ +85°C.

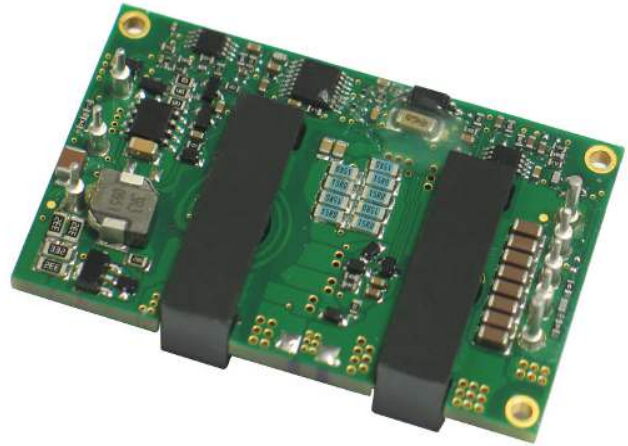

Operational Features

- Delivering up to 8.3A output current
- High efficiency: 92.9% typ., at full load
- Wide input range: 36V ~ 75V
- Excellent thermal performance
- No minimum load requirement
- RoHS 5 compliant

Control Features

- Remote control function (negative or positive logic optional)
- Remote output sense
- Trim function: -20% ~ +10%

Protection Features

- Input under voltage lockout
- Output over current protection
- Output over voltage protection
- Over temperature protection

Mechanical Features

- Industry standard quarter-brick pin-out outline
- Open frame structure
- Pin length: 3.8mm

Safety & EMC

- Meet latest safety standards UL 60950-1, CSA-C22.2 NO.60950-1, IEC/EN 60950-1 and GB4943
- Approved by UL and TUV
- Meet 2006/95/EEC and 93/68/EEC directives which facilitate CE marking in user's end product
- Meet conducted emission's requirements of FCC Class A and EN55022 Class A, tested with external filter
- Material meets UL 94-V0

Electrical Characteristics

Full operating ambient temperature range is -40°C to +85°C.

Specifications are subject to change without notice.

Parameter		Min.	Typ.	Max.	Unit	Notes & conditions
Absolute max. ratings						
Input voltage	Non-operating			100	V	100ms
	Operating			80	V	Continuous
Operating temperature		-40		85	°C	
Storage temperature		-55		125	°C	
Voltage at remote ON/OFF pin		-0.7		12	V	
Input characteristics						
Operating input voltage range		36	48	75	V	
Input under-voltage lockout	Turn-on voltage threshold	31	34.6	36	V	
	Turn-off voltage threshold	30	32.7	35	V	
	Lockout voltage hysteresis	1	2	3	V	
Max. input current			2.95	3.5	A	36V _{in} , full load
No-load input current			79	100	mA	48V _{in} , no load
Standby Input current			9	20	mA	Remote OFF
Inrush current transient rating				1	A ² s	See Figure 16
Input reflected ripple current			30	40	mA	Through 12μH inductor; see Figure 16
Recommended input fuse				5	A	External fast blow fuse recommended; see Figure 11
Input filter component values (CL)			2.0\3.3		μF\μH	Internal values
Recommended external input capacitance		100			μF	Low ESR capacitor recommended; see Figure 11
Output characteristics						
Output voltage set point (standard option)		11.88	12.00	12.12	V	48V _{in} , full load
Output voltage line regulation			0.08	0.2	%	
					mV	
Output voltage load regulation			0.08	0.5	%	
					mV	

Parameter		Min.	Typ.	Max.	Unit	Notes & conditions
Output voltage temperature regulation			0.001	0.02	%/°C	
Total output voltage range		9.6	12	13.2	V	Over sample, line, load, temperature & life
Output voltage ripple and noise			100	180	mVpp	See Figure 2. 20MHz bandwidth; see Figure 16
Operating output current range		0		8.3	A	
Output DC current-limit inception		9	11.5	13.5	A	Hiccup: auto-restart when over-current condition is removed
Output capacitance		220		2200	μF	High frequency and low ESR is recommended
Dynamic characteristics						
Dynamic response	50% ~ 75% ~ 50% $I_{o,max}$, 0.1A/μs		122	480	mV	See Figure 4. Test condition: 25°C, nominal input voltage, see Figure 11
	Settling time		330	700	μs	Recovery to within 1% $V_{o,nom}$
	10% ~ 50% ~ 10% $I_{o,max}$, 0.1A/μs		350	600	mV	See Figure 5. Test condition: 25°C, nominal input voltage, see Figure 11
	Settling time				μs	
Turn-on transient	Rise time		21	50	ms	Full load, see Figure 6
	Turn-on delay time		4.6	50	ms	
	Output voltage overshoot		0	5	% V_o	
Efficiency						
100% load			92.9		%	See Figure 1
50% load			92.08		%	See Figure 1
Isolation characteristics						
Isolation voltage (conditions: 1mA for 60s, slew rate of 1500V/10s)		1500			Vdc	Basic insulation, input to output

Electrical Characteristics (Continued)

Parameter		Min.	Typ.	Max.	Unit	Notes & conditions
Feature characteristics						
Switching frequency		280	310	340	kHz	
Remote ON/OFF control (positive logic)	Off-state voltage	-0.7		1.2	V	See Figure 12
	On-state voltage	3.5		12	V	
Remote ON/OFF control (negative logic)	Off-state voltage	3.5		12	V	
	On-state voltage	-0.7		1.2	V	
Output voltage trim range		-20		10	%	See <i>Trim Characteristics of Application Note</i>
Output voltage remote sense range				5	%	
Output over-voltage protection		14.4	15.8	18	V	Hiccup
Over-temperature shutdown			122	130	°C	Auto recovery; OTP test point, see Figure 10
Over-temperature hysteresis			20		°C	
Reliability characteristics						
Calculated MTBF (telcordia)			1.5		10 ⁶ h	Telcordia SR-332-2006; 80% load, 300LFM, 40°C T _a

Electromagnetic Compatibility Requirements

Test item	Regulations	Criteria	Notes & conditions
Conducted emission	EN 55022 DC input port, Class A		See <i>EMC Test Conditions</i>
Immunity to electrostatic discharge	IEC/EN61000-4-2 Enclosure port, Level 3	B	
Immunity to electrical fast transient	IEC/EN61000-4-4 DC input port, Level 3	B	
Immunity to surges	IEC/EN61000-4-5 DC input port Line to Ground (earth): 600V Line to Lineline: 600V	B	
Immunity to continuous conducted interference	IEC/EN61000-4-6 DC input port, Level 2	A	
Immunity to voltage dips and short interruptions and voltage variations	EN 61000-4-29 DC input port	B	

Criterion A: Normal performance during and after test.

Criterion B: For EFT and surges, low-voltage protection or reset is not allowed. Temporary output voltage fluctuation ceases after disturbances ceases, and from which the EUT recovers its normal performance automatically.

For Dips and ESD, output voltage fluctuation or reset is allowed during the test, but recovers to its normal performance automatically after the disturbance ceases.

Criterion C: Temporary loss of output, the correction of which requires operator intervention.

Criterion D: Loss of output which is not recoverable, owing to damage to hardware.

Qualification Testing

Parameter	Unit (pcs)	Test condition
Halt test	4 ~ 5	$T_{a,min} - 10^{\circ}\text{C}$ to $T_{a,max} + 10^{\circ}\text{C}$, 5°C step, V_{in} = min to max, 0 ~ 105% load
Vibration	3	Frequency range: 5Hz ~ 20Hz, 20Hz ~ 200Hz, A.S.D: $1.0\text{m}^2/\text{s}^3$, -3db/oct, axes of vibration: X/Y/Z Time: 30min/axis
Mechanical shock	3	30g, 6ms, 3axes, 6directions, 3time/direction
Thermal shock	3	-40°C to 100°C , unit temperature 20cycles
Thermal cycling	3	-40°C to 55°C , temperature change rate: $1^{\circ}\text{C}/\text{min}$, cycles: 2cycles
Humidity	3	40°C , 95%RH, 48h
Solder ability	15	IPC J-STD-002C-2007

Characteristic Curves

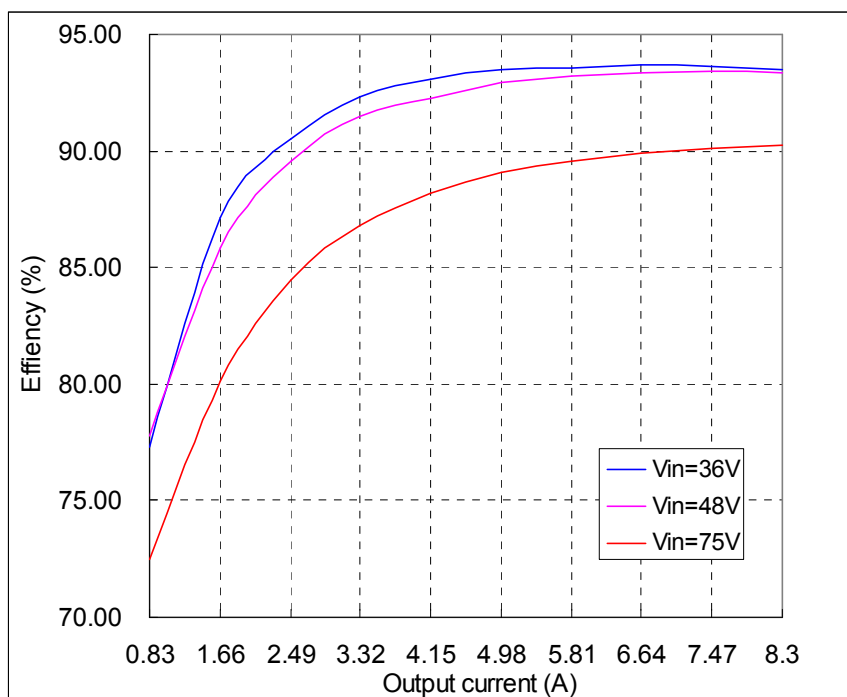

Figure 1 Efficiency vs. output current, $T_a=25^{\circ}\text{C}$

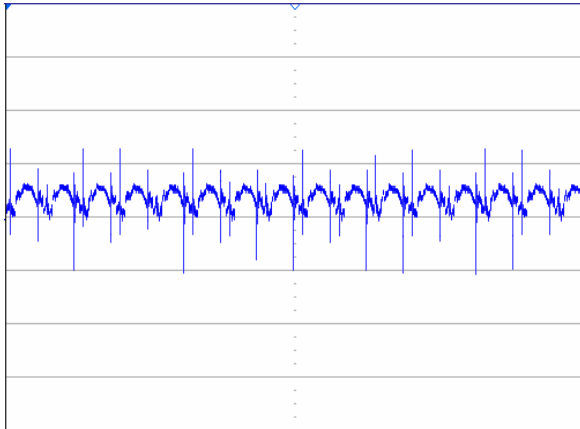

Figure 2 Output ripple & noise (5ms/div, 20mV/div), see Figure 16 for test configuration

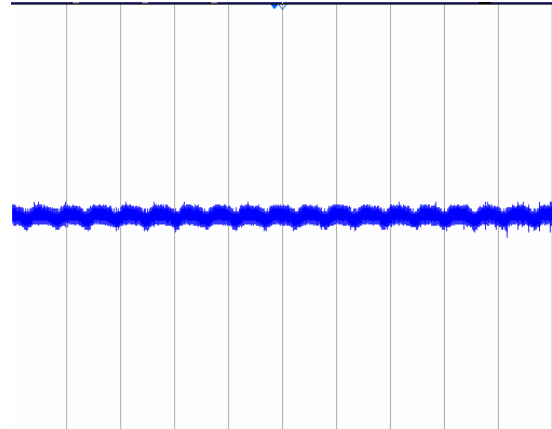

Figure 3 Input reflected ripple current (2µs/div, 50mA/div), see Figure 16 for test configuration

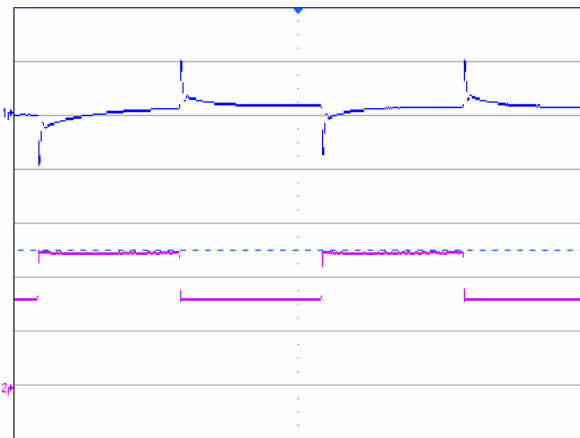

Figure 4 Dynamic response for 25% load step (50% ~ 75% ~ 50%) and 0.1A/µs slew rate, (2ms/div), see Figure 11 for test configuration; CH1-output voltage (200mV/div); CH2-output current (2.5A/div)

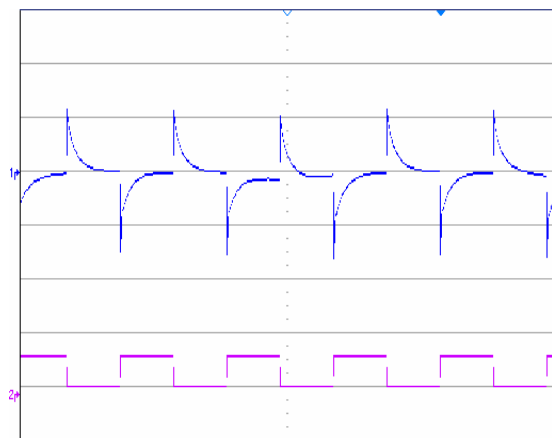

Figure 5 Dynamic response for 40% load step (50% ~ 10% ~ 50%) and 0.1A/µs slew rate, (2ms/div), see Figure 11 for test configuration; CH1-output voltage (200mV/div); CH2-output current (10A/div)

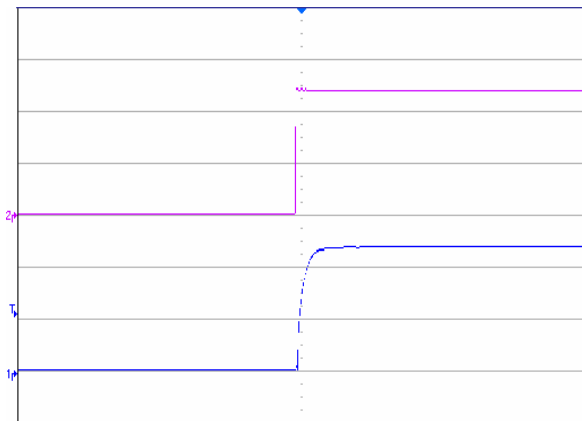

Figure 6 Output voltage startup by power on, (50ms/div), see Figure 11 for test configuration; CH1-output voltage (5V/div); CH2-input voltage (20V/div)

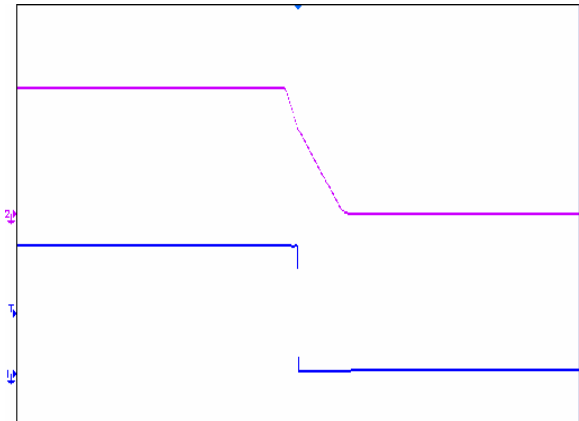

Figure 7 Output voltage startup by shutdown, (100ms/div), see Figure 11 for test configuration; CH1-output voltage (5V/div); CH2-input voltage (20V/div)

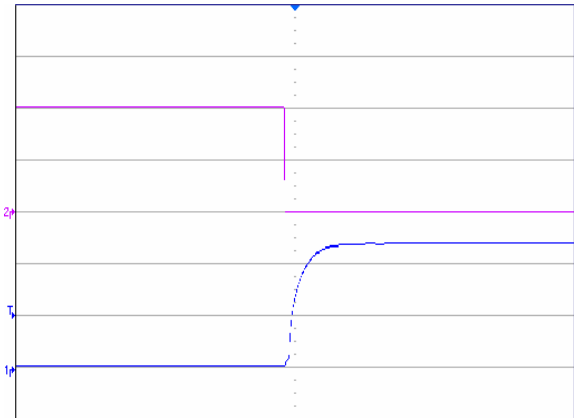

Figure 8 Output voltage startup by remote ON of negative module, (50ms/div), see Figure 11 for test configuration; CH1-output voltage (5V/div); CH2-remote ON voltage (2V/div)

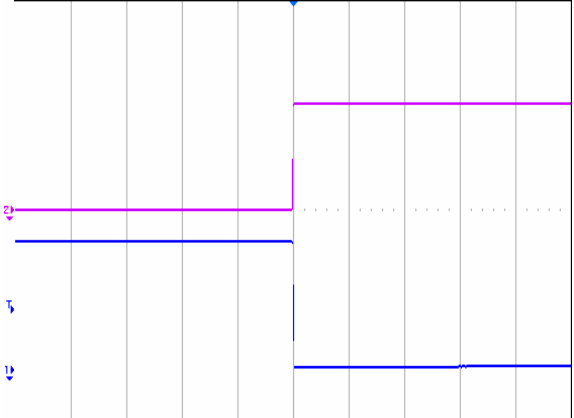

Figure 9 Output voltage shutdown by remote OFF of negative module, (50ms/div), see Figure 11 for test configuration; CH1-output voltage (5V/div); CH2-remote OFF voltage (2V/div)

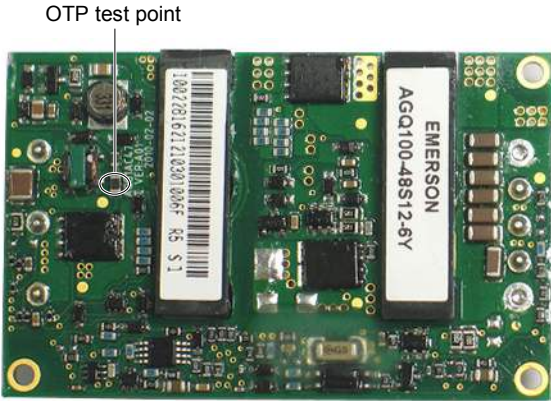

Figure 10 OTP test point

Application Note

Typical Application

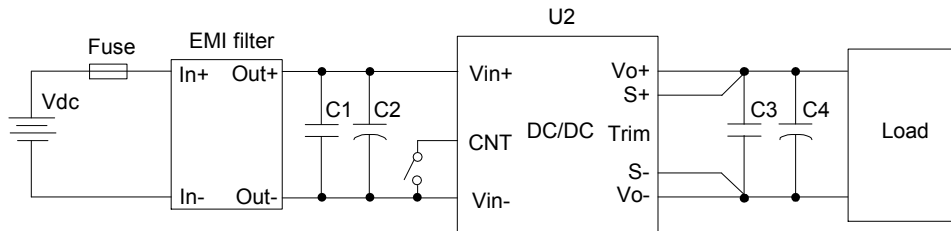

Figure 11 Typical application

C1: 1 μ F/100V X7R ceramic capacitor, P/N: C3225X7R2A105KT0L0U (TDK) or equivalent caps

C2: 100 μ F/100V electrolytic capacitor, P/N: UVZ2A101MHD (Nichicon) or equivalent caps

C3: 1 μ F/25V X7R ceramic capacitor, P/N: C2012X7R1E105KT000N (TDK) or equivalent caps

C4: 220 μ F electrolytic capacitor, P/N: UPM1E221MHD (Nichicon) or equivalent caps

U2: Module to test, AGQ100-48S12

Fuse: External fast blow fuse with a rating of 5A. The recommended fuse model is 314005 MXP from LITTLEFUSE.

Remote ON/OFF

Either positive or negative remote ON/OFF logic is available in AGQ100-48S12. The logic is CMOS and TTL compatible.

Figure 12 is the detailed internal circuit and reference in AGQ100-48S12.

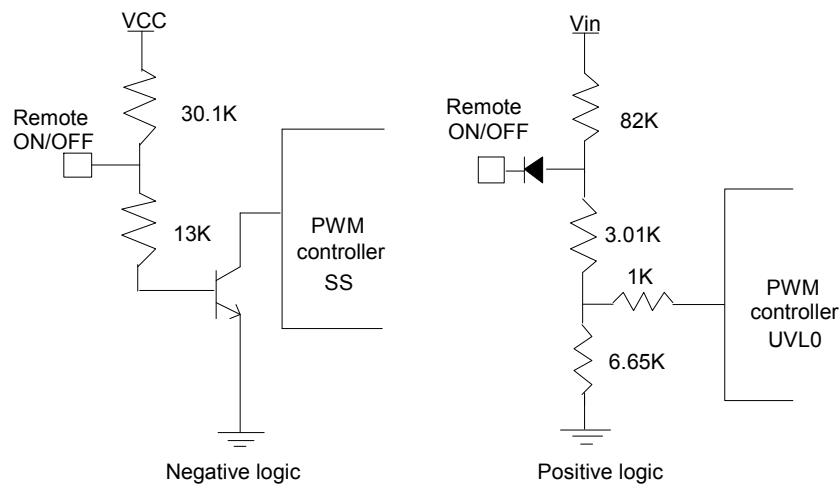

Figure 12 Remote ON/OFF internal diagram

The voltage between pin Remote ON/OFF and pin Vin- must not exceed the range listed in table “Feature characteristics” to ensure proper operation. The external remote ON/OFF circuit is highly recommended as shown in Figure 13.

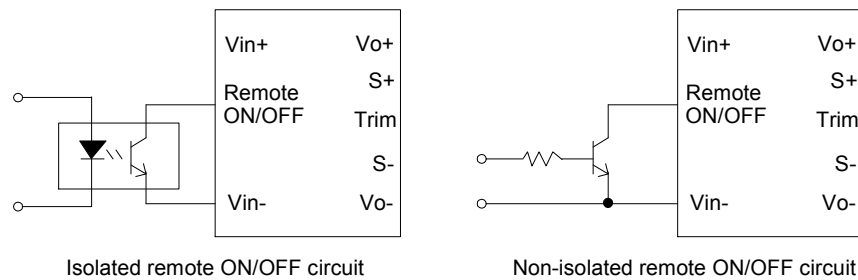

Figure 13 External remote ON/OFF circuit

Trim Characteristics

Connecting an external resistor between Trim pin and Vo- pin will decrease the output voltage. Connecting it between Trim pin and Vo+ pin will increase the output voltage. The following equations determine the external resistance to obtain the trimmed output voltage.

$$R_{adj-down} = \frac{511}{\Delta} - 10.22(K\Omega)$$

$$R_{adj-up} = \frac{5.11 \times V_{nom} \times (100 + \Delta)}{1.225 \times \Delta} - \frac{511}{\Delta} - 10.22(K\Omega)$$

$$\Delta = \frac{|V_{nom} - V_{desired}|}{V_{nom}} \times 100$$

V_{nom} : Nominal output voltage.

For example, to get 13.12V output, the trimming resistor is

$$R_{adj-up} = \frac{5.11 \times 12 \times (100 + 10)}{1.225 \times 10} - \frac{511}{10} - 10.22(K\Omega) = 489.3(K\Omega)$$

The output voltage can also be trimmed by potential applied at the Trim pin.

$$V_o = (V_{trim} + 1.225) \times 6.122$$

Where V_{trim} is the potential applied at the Trim pin, and V_o is the desired output voltage.

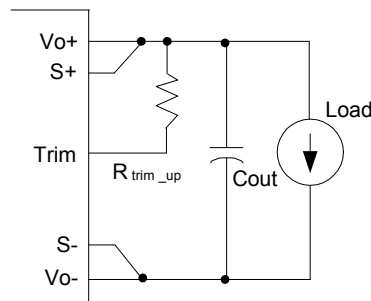

Figure 14 Trim up

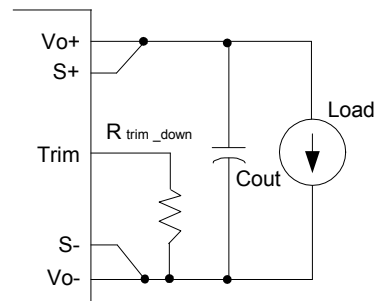

Figure 15 Trim down

Sense Characteristics

If the load is far from the unit, connect S+ and S- to the terminal of the load respectively to compensate the voltage drop on the transmission line. If the sense compensate function is not necessary, connect S+ to V_{o+} and S- to V_{o-} directly.

Input Ripple & Inrush Current And Output Ripple & Noise Test Configuration

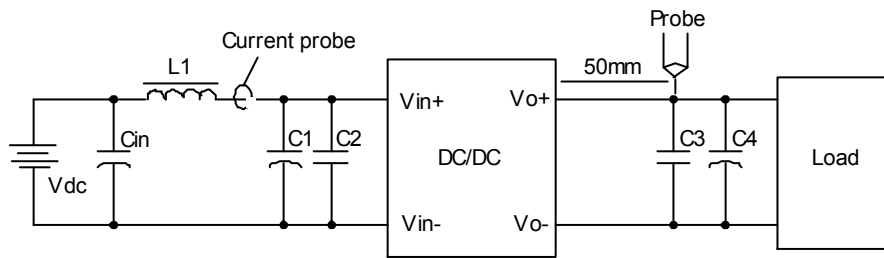

Figure 16 Input ripple & inrush current, output ripple & noise test configuration

Vdc: DC power supply

L1: 12μH

Cin: 220μF/100V typical

C1 ~ C4: See Figure 11

Note: It is recommended to use a coaxial cable with series 50Ω resistor and 0.68μF ceramic capacitor or a ground ring of probe to test output ripple & noise.

EMC Test Conditions

The customer actual EMI circuit is shown in the following figure.

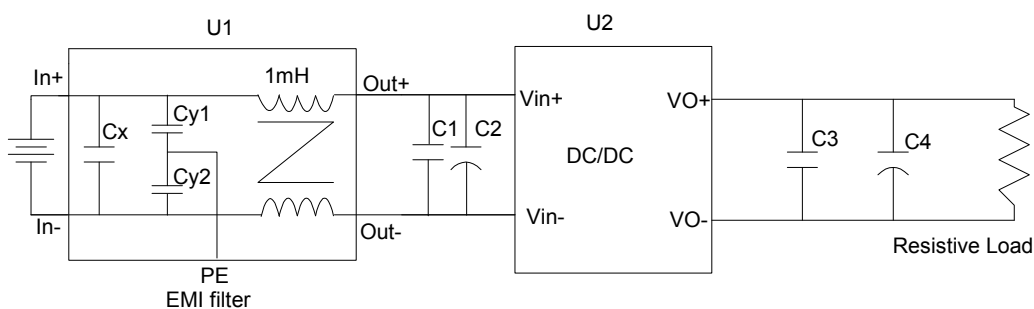

Figure 17 EMC test configuration

CX: 1μF/100V ceramic capacitor, C3225X7R2A225KT0LOU/TKD

Cy1, Cy2: 2200pF/1000V ceramic capacitor, GHM1535X7R223K1KD550/MURATA

C1: 0.1μF/100V ceramic capacitor, C1206X7R2A105KT0LOU/TKD

C2: 100μF/100V low ESR aluminum electrolytic capacitor, UVZ2A101MPD

C3: 1μF/25V ceramic capacitor, C2012X7R1E105KT000N/TKD

C4: 220μF/100V low ESR aluminum electrolytic capacitor, UPM1E221MHD

Thermal Considerations

The converter is designed to operate in different thermal environments and sufficient cooling must be provided. Proper cooling can be verified by measuring the temperature at the temperature test point. The temperature at this point should not exceed the maximum value in Table 1.

For a typical application, Figure 20 shows the derating of output current vs. ambient air temperature at different air velocity.

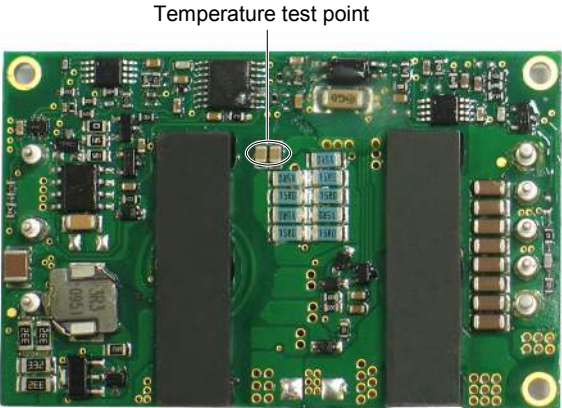

Figure 18 Temperature test point

Table 1 Temperature limit of test point

Test point	Temperature limit
Temperature test point	116°C

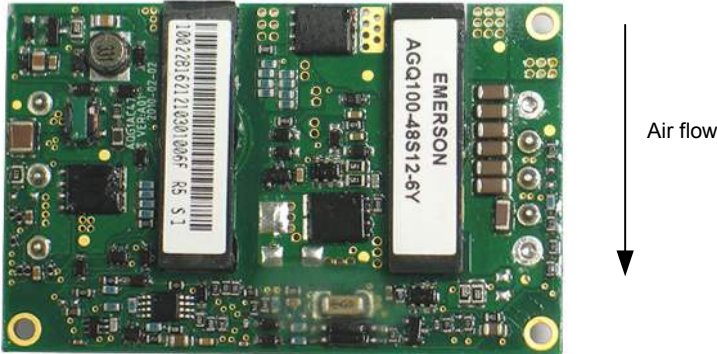

Figure 19 Typical test condition, forced airflow direction is from V_{o+} to V_{o-}

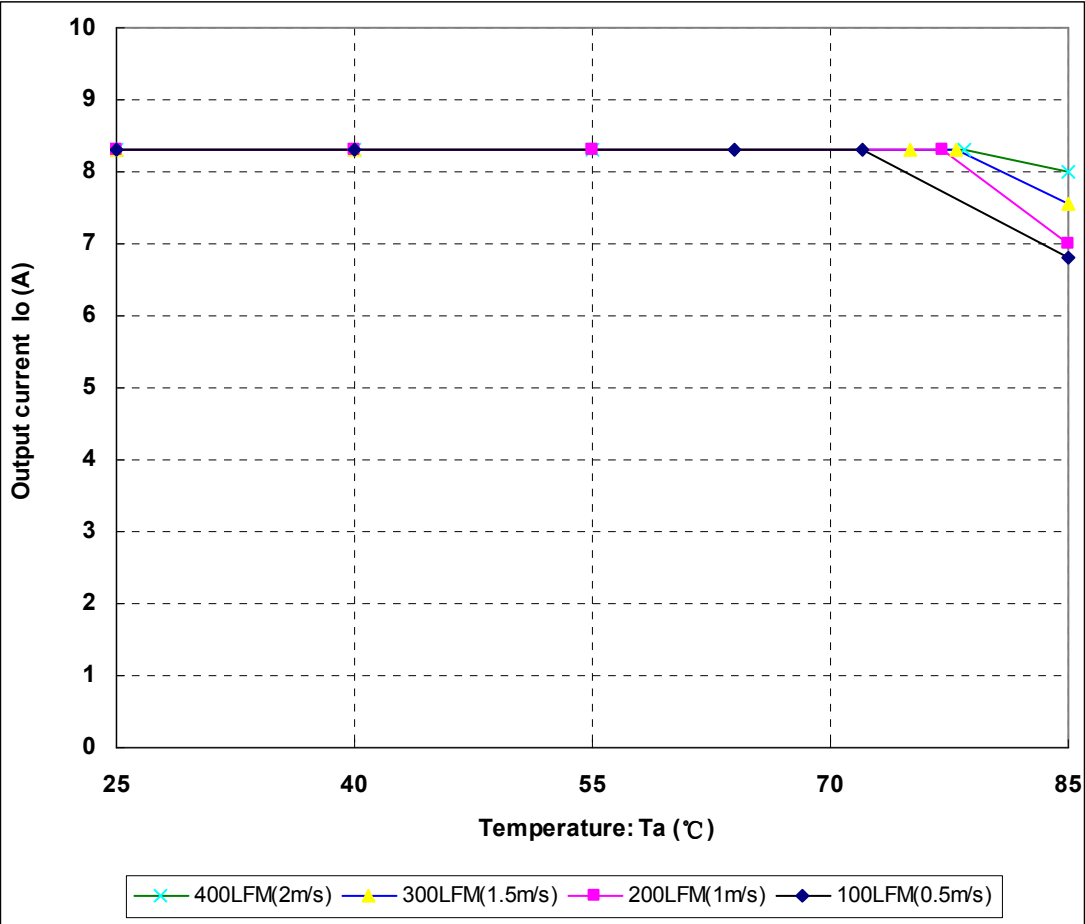
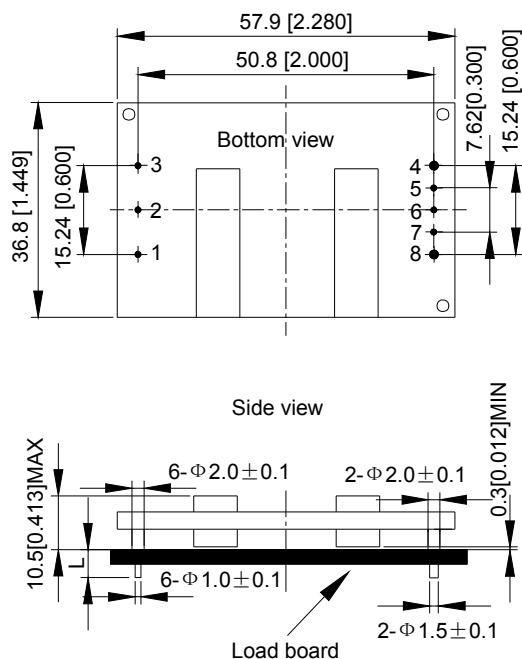

Figure 20 Output power derating, 48V_{in}, air flowing across the converter from V_{o+} to V_{o-}

Mechanical Diagram



Unit: mm[inch] Bottom view: pin on upside

Tolerance: X.Xmm ± 0.5mm[X.X in. ± 0.02in.]

X.XXmm ± 0.25mm[X.XX in. ± 0.01in.]

Figure 21 Mechanical diagram

Pin length option

Device code suffix	L
-4	4.8mm ± 0.25mm
-6	3.8mm ± 0.25mm
-8	2.8mm ± 0.25mm
None	5.8mm ± 0.25mm

Pin Designations

Pin No.	Name	Function
1	V _{in+}	Positive input voltage
2	Remote ON/OFF	Remote control
3	V _{in-}	Negative input voltage
4	V _{o-}	Negative output voltage
5	S-	Negative remote sense
6	Trim	Output voltage trim
7	S+	Positive remote sense
8	V _{o+}	Positive output voltage

Soldering

The product is intended for standard manual wave soldering.

When wave soldering is used, the temperature on pins is specified to maximum 260°C for maximum 7s.

When soldering by hand, the iron temperature should be maintained at 300°C ~ 380°C and applied to the converter pins for less than 10s. Longer exposure can cause internal damage to the converter.

Cleaning of solder joint can be performed with cleaning solvent IPA or simulative.

Ordering Information

AGQ100	-	48	S	12	-	6	Y
①		②	③	④		⑥	⑦

①	Model series	AGQ: high efficiency quarter-brick series, 100: output power 100W
②	Input voltage	48: 36V ~ 75V input range, rated input voltage 48V
③	Output number	S: single output
④	Rated output voltage	12:12V output
⑥	Pin length	-6: 3.8mm
⑦	RoHS status	L: RoHS, R6; Y: RoHS, R5

Model number	Description
AGQ100-48S12-6Y	3.8mm pin length; negative on/off logic; without thread inside mounting hole; R5 compliant
AGQ100-48S12B-6Y	3.8mm pin length; negative on/off logic; without thread inside mounting hole; R5 compliant; baseplated; for detailed information, refer to <i>AGQ100-48S12B Technical Reference Notes</i>

Hazardous Substances Announcement (RoHS Of China)

Parts	Hazardous substances					
	Pb	Hg	Cd	Cr ⁶⁺	PBB	PBDE
AGQ100-48S12	√	x	x	x	x	x
<p>x: Means the content of the hazardous substances in all the average quality materials of the part is within the limits specified in SJ/T-11363-2006</p> <p>√: Means the content of the hazardous substances in at least one of the average quality materials of the part is outside the limits specified in SJ/T11363-2006</p> <p>Emerson Network Power Co., Ltd. has been committed to the design and manufacturing of environment-friendly products. It will reduce and eventually eliminate the hazardous substances in the products through unremitting efforts in research. However, limited by the current technical level, the following parts still contain hazardous substances due to the lack of reliable substitute or mature solution:</p> <ol style="list-style-type: none"> 1. Solders (including high-temperature solder in parts) contain plumbum. 2. Glass of electric parts contains plumbum. 3. Copper alloy of pins contains plumbum 						