

Verpackt in Gurtverpackung - Tape on Reel Packaging
 Verpackungseinheit: 400 Stück - Packaging unit: 400 pcs

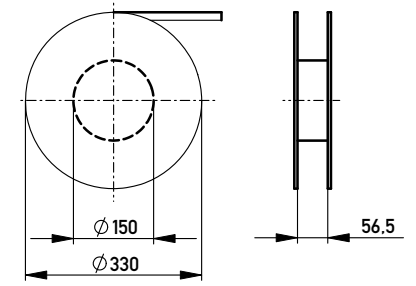

Abspulrichtung - Reel off Direction

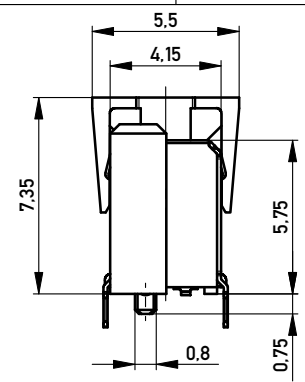
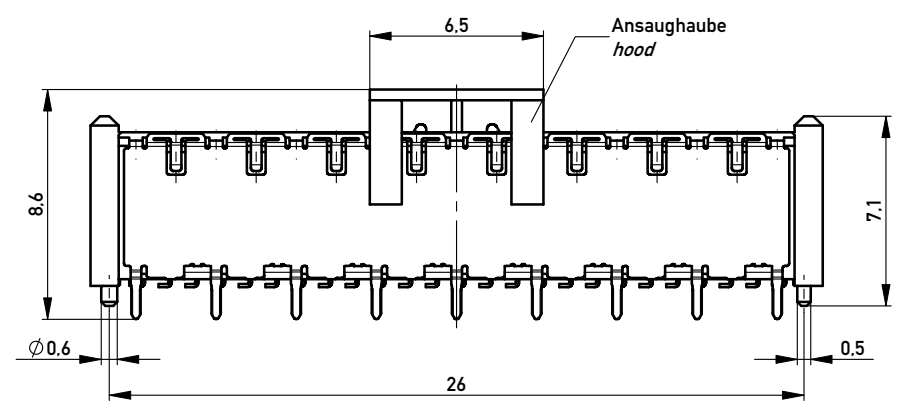
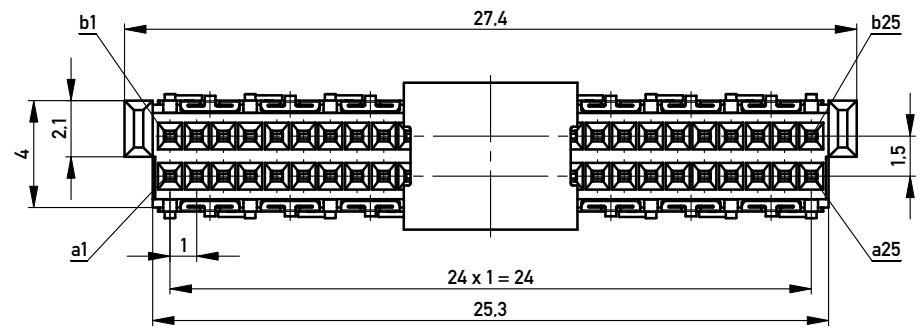
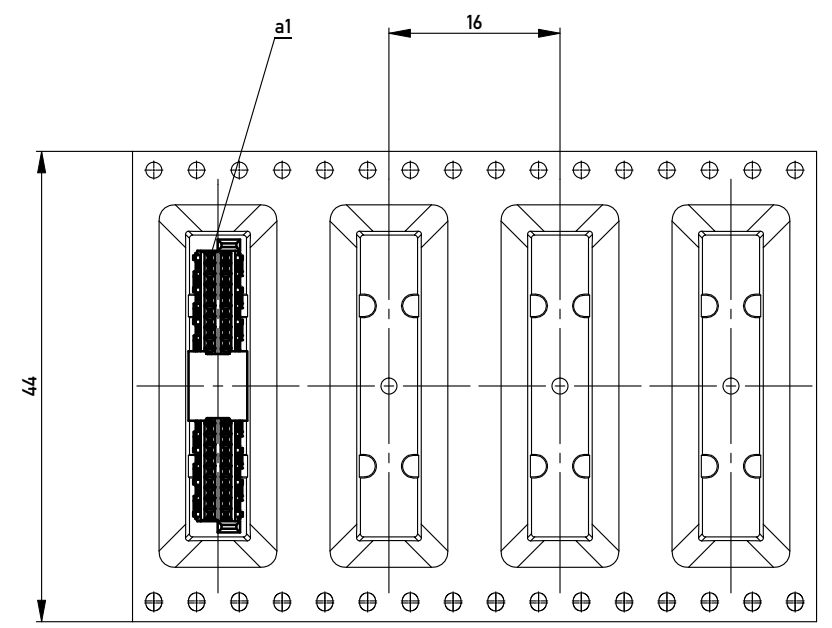

Leiterplatten-Layout Vorschlag / PCB-Layout Proposal

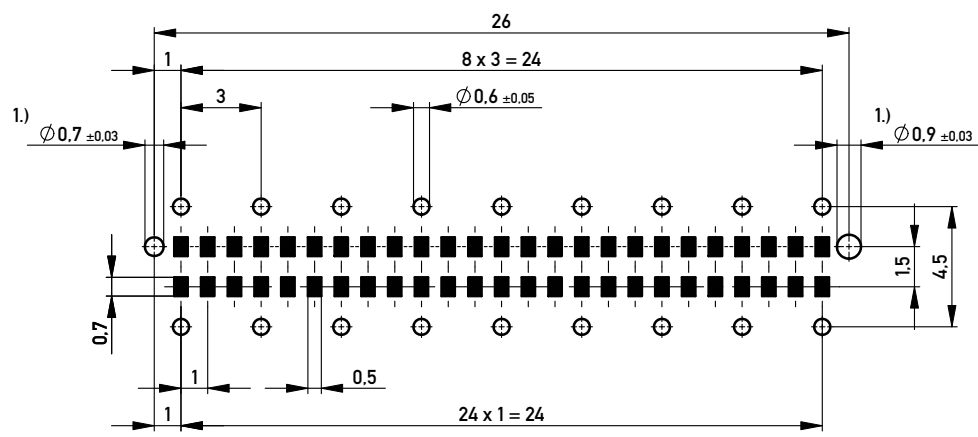

Anforderungsstufe 1
 Performance Level 1

Kontaktbereich vergoldet
 Mating Area gold plating

Anschlussbereich verzinkt 4-6µm
 Terminal Area 4-6µm tin plating

Koplanarität der Anschlüsse ≤ 0.1mm
 Coplanarity Area of Termination ≤ 0.1mm

1.) Durchmesser des Bohrers / Drill tool

Information:	Tolerances	 All Dimensions in mm	Scale	5:1
	All rights reserved. Only for Information. To ensure that this is the latest version of this drawing, please contact one of the ERNI companies before using.		Designation F06 MSpeed BlindMate 50 THR	
Subject to modification without prior notice. Drawing will not be updated.		www.ERNI.com	354177	
a	01.09.2010		Class	MSPEED
Index	Date			A3

Copyright by ERNI GmbH. Proprietary notice pursuant to ISO 16106 to be observed.