

DO NOT SCALE FROM THIS PRINT

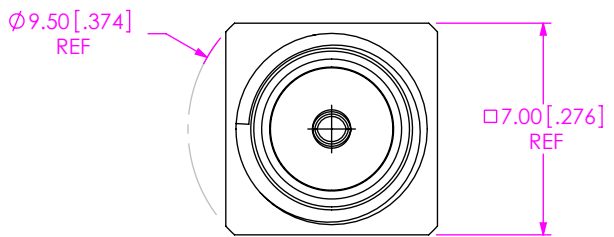

TABLE 1		
ITEM	COMPONENT	-H
1	SHELL	SMA-J-P-F-ST-TH1-SHL
2	RING	SMA-J-P-F-ST-TH1-RNG
3	INSULATOR	SMA-J-P-TH1-INS
4	SOCKET	SMA-SKT-005-H

SMA-J-P-X-ST-TH1

GENDER
-J: JACK

TERMINATION
-TH1: THROUGH HOLE

TYPE
-P: PCB

ORIENTATION
-ST: STRAIGHT

PLATING SPECIFICATION
-H: 30μ" MIN GOLD OVER 50μ" MIN NICKEL CENTER CONTACT,
3μ" MIN GOLD OVER 50μ" MIN NICKEL OUTER CONTACT
(SEE TABLE 1)

DESIGNED & DIMENSIONED IN MILLIMETERS[INCHES]

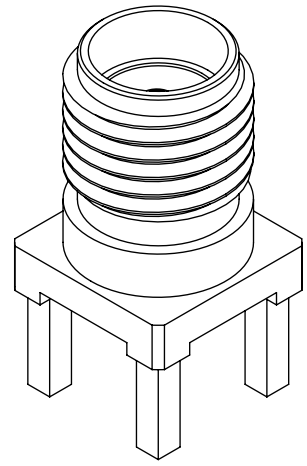
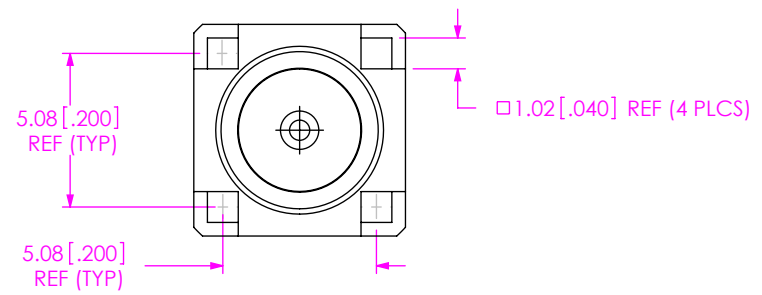
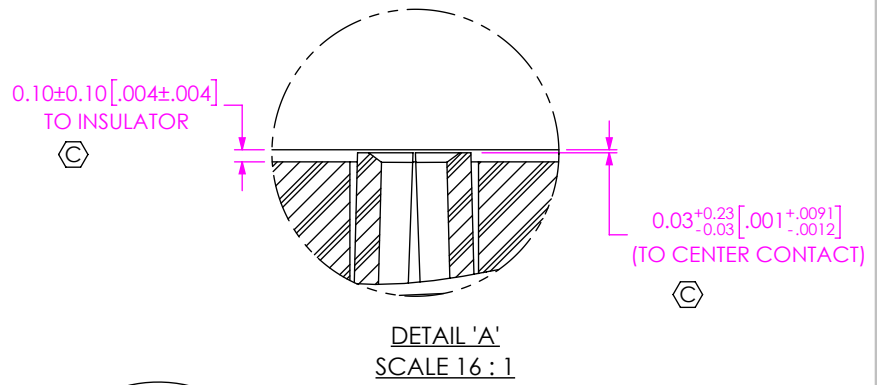
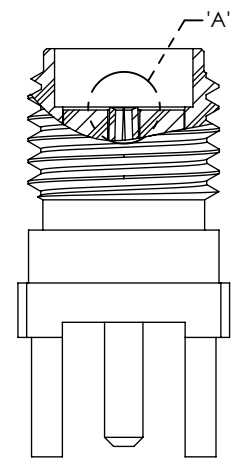
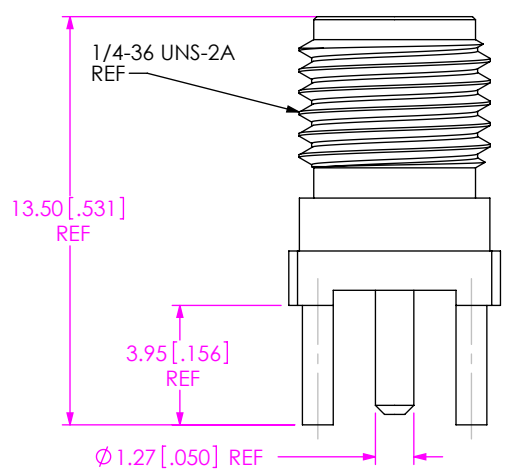

RECOMMENDED PCB LAYOUT

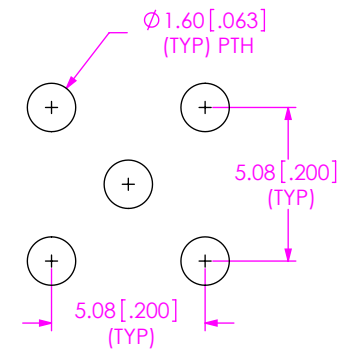

NOTES:

1. Ⓢ REPRESENTS A CRITICAL DIMENSION.
2. MINIMUM PUSHOUT FORCE FOR INSULATOR: 44.48 N [10 LB].
3. MINIMUM CENTER CONTACT PUSHOUT FORCE: 13.35 N [3 LBS].
4. PRODUCT TO BE PACKAGED PER PACKAGING STANDARD CO-RF-WI-3040-M.
5. NOTE DELETED.
6. NOTE DELETED.
7. NOTE DELETED.

UNLESS OTHERWISE SPECIFIED, DIMENSIONS ARE IN MILLIMETERS INCHES.

TOLERANCES ARE:

DECIMALS	ANGLES
.X: ±0.3 [0.01]	5°
.XX: ±0.13 [0.005]	
.XXX: ±0.051 [0.0020]	

PROPRIETARY NOTE
THIS DOCUMENT CONTAINS CONFIDENTIAL AND PROPRIETARY INFORMATION AND ALL DESIGN, MANUFACTURING, REPRODUCTION, USE, PATENT RIGHTS AND SALES RIGHTS ARE EXPRESSLY RESERVED BY SAMTEC, INC. THIS DOCUMENT SHALL NOT BE DISCLOSED, IN WHOLE OR PART, TO ANY UNAUTHORIZED PERSON OR ENTITY NOR REPRODUCED, TRANSFERRED OR INCORPORATED IN ANY OTHER PROJECT IN ANY MANNER WITHOUT THE EXPRESS WRITTEN CONSENT OF SAMTEC, INC.

MATERIAL: DO NOT SCALE DRAWING SHEET SCALE: 4:1

SHELL, RING: BRASS
SOCKET: COPPER ALLOY
DIELECTRIC: PTFE

520 PARK EAST BLVD, NEW ALBANY, IN 47150
PHONE: 812-944-6733 FAX: 812-948-5047
e-Mail: info@SAMTEC.com code: 55322

DESCRIPTION:
SMA STRAIGHT, THROUGH HOLE JACK - 50 OHM

DWG. NO.
SMA-J-P-X-ST-TH1

BY: R MUSSER 01/28/2008 SHEET 1 OF 1