

REVISIONS					
REV	DATE	DESCRIPTION	BY	CHK	APPV
A1	24APR10	REVISED PER ECO-10-008611	HMR	NE	
A2	30MAY2017	REVISED PER ECO-16-018096	RK	PO	

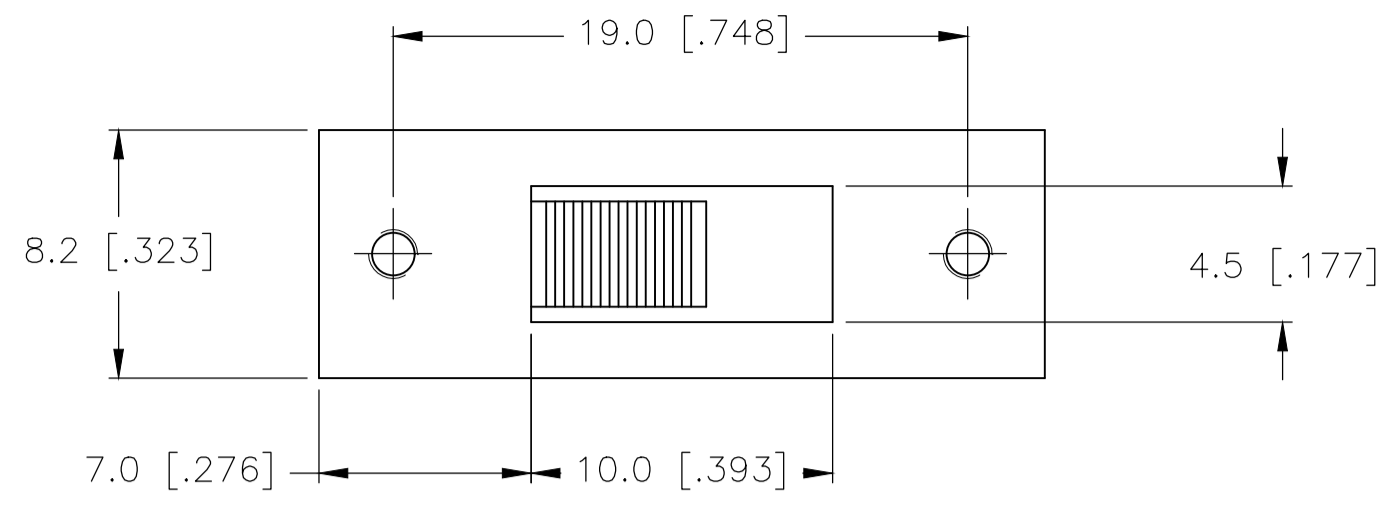

SPECIFICATIONS  
MAKE-BEFORE-BREAK

MATERIALS:  
 ACTUATOR- POM, UL94HB BLACK  
 TERMINAL BOARD- PHENOLIC LAMINATED SHEET, UL94HB, NATURAL  
 FRAME- STEEL, NICKEL PLATE  
 TERMINAL/FIXED CONTACT- COPPER ALLOY, GOLD OR SILVER OVER NICKEL PLATE  
 MOVING CONTACT- COPPER ALLOY, GOLD OR SILVER OVER NICKEL PLATE  
 DETENT BALL- STEEL  
 COIL SPRING- GALVANIZED SPRING WIRE  
 SEAL- EPOXY

ELECTRICAL:  
 CONTACT RATING- .4VA@20VDC OR PEAK AC (GOLD); 300mA@125V AC (SILVER)  
 INITIAL CONTACT RESISTANCE- 30 milliohm max.  
 FINAL CONTACT RESISTANCE- 100 milliohm max. (AFTER TEST)  
 INSULATION RESISTANCE- 1,000 Megohms min.  
 DIELECTRIC STRENGTH- 500V RMS@SEA LEVEL  
 LIFE EXPECTANCY- 15,000 CYCLES MIN.

MECHANICAL:  
 ACTUATION FORCE- 600+/-300 GRAMS  
 TRAVEL- 2.0 +/-0.50 (0.079 +/-0.020)

ENVIRONMENTAL:  
 OPERATING TEMPERATURE- -20 TO +85 DEGREES C  
 STORAGE TEMPERATURE- -40 TO +100 DEGREES C  
 RESISTANCE TO SOLDER HEAT PER 109-202, CONDITION B  
 SOLDERABILITY PER EIA-364-52, CLASS 2, CATEGORY 1, 95% MIN COVERAGE

NOTES:

- 1 COUNTRY OF ORIGIN AND TE LOGO LOCATED APPROXIMATELY AS SHOWN
2. ALL MATERIALS AND FINISHES SHALL COMPLY WITH EU DIRECTIVE 2002/95/EC OF 27JAN2003 (ROHS)
- 3 ANTI SOLDER WICK SEAL AT TERMINAL TO BOARD INTERFACE
4. ALL PERFORMANCE TESTING WAS DONE IN ACCORDANCE TO TE SPECIFICATION 102-2469

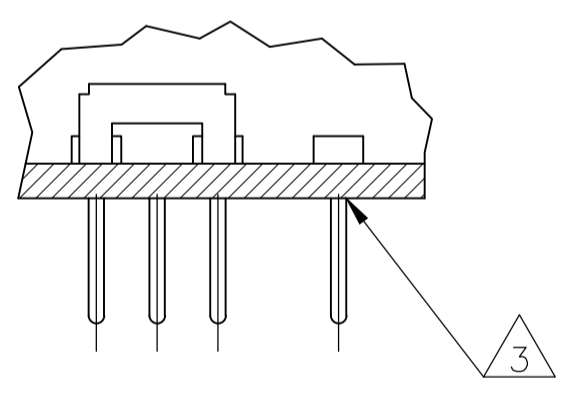
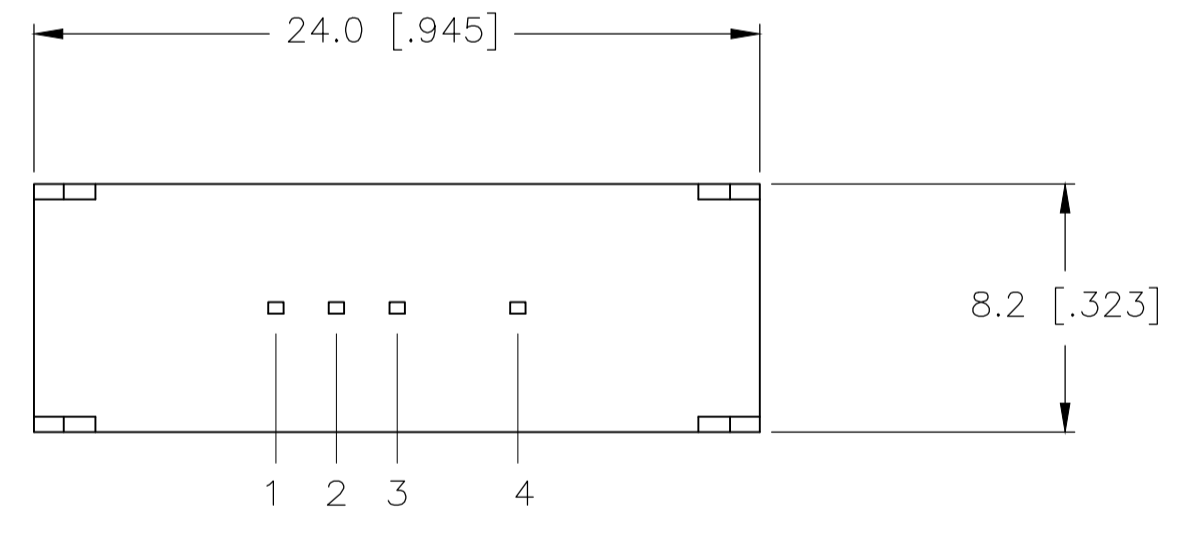
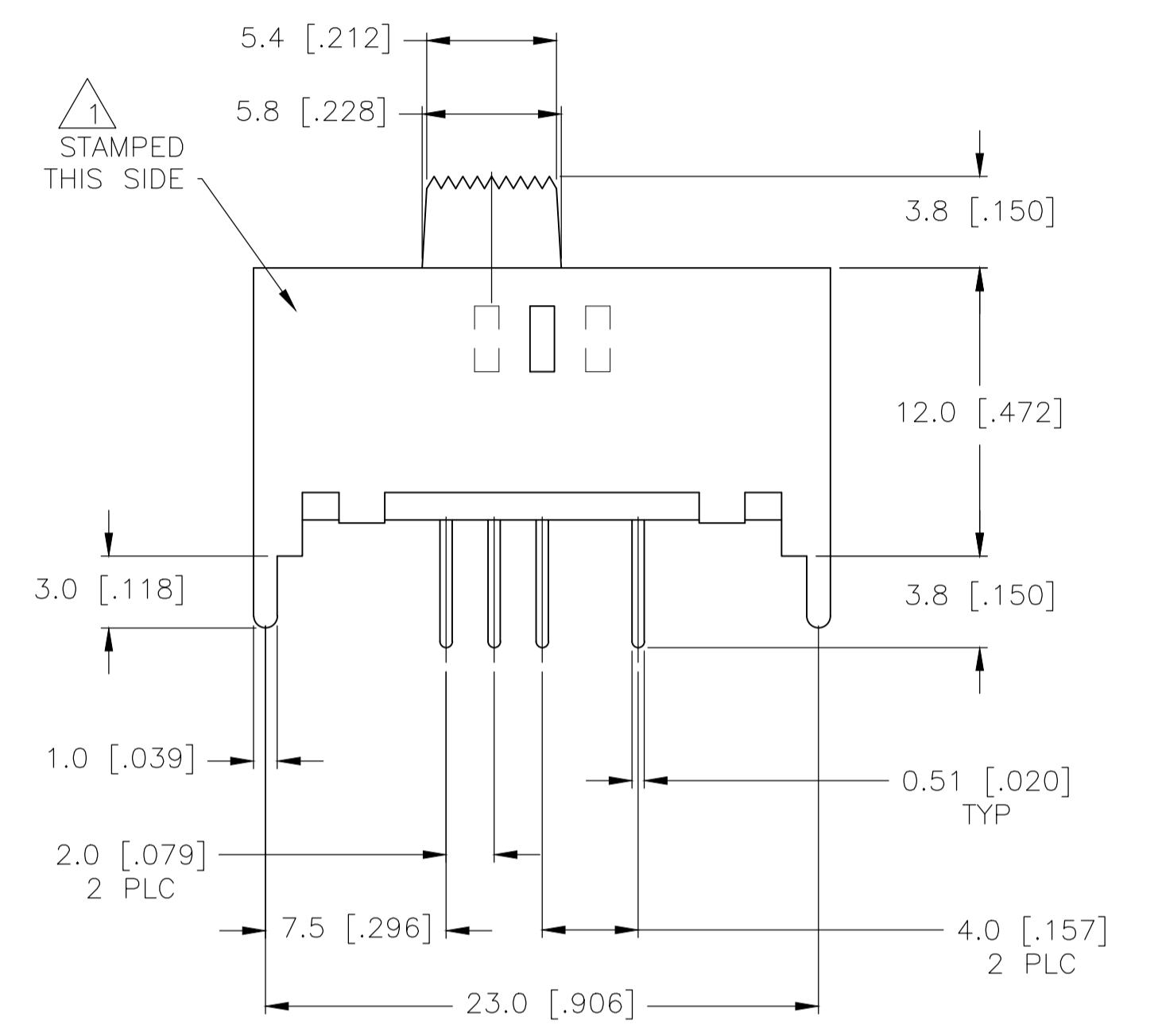
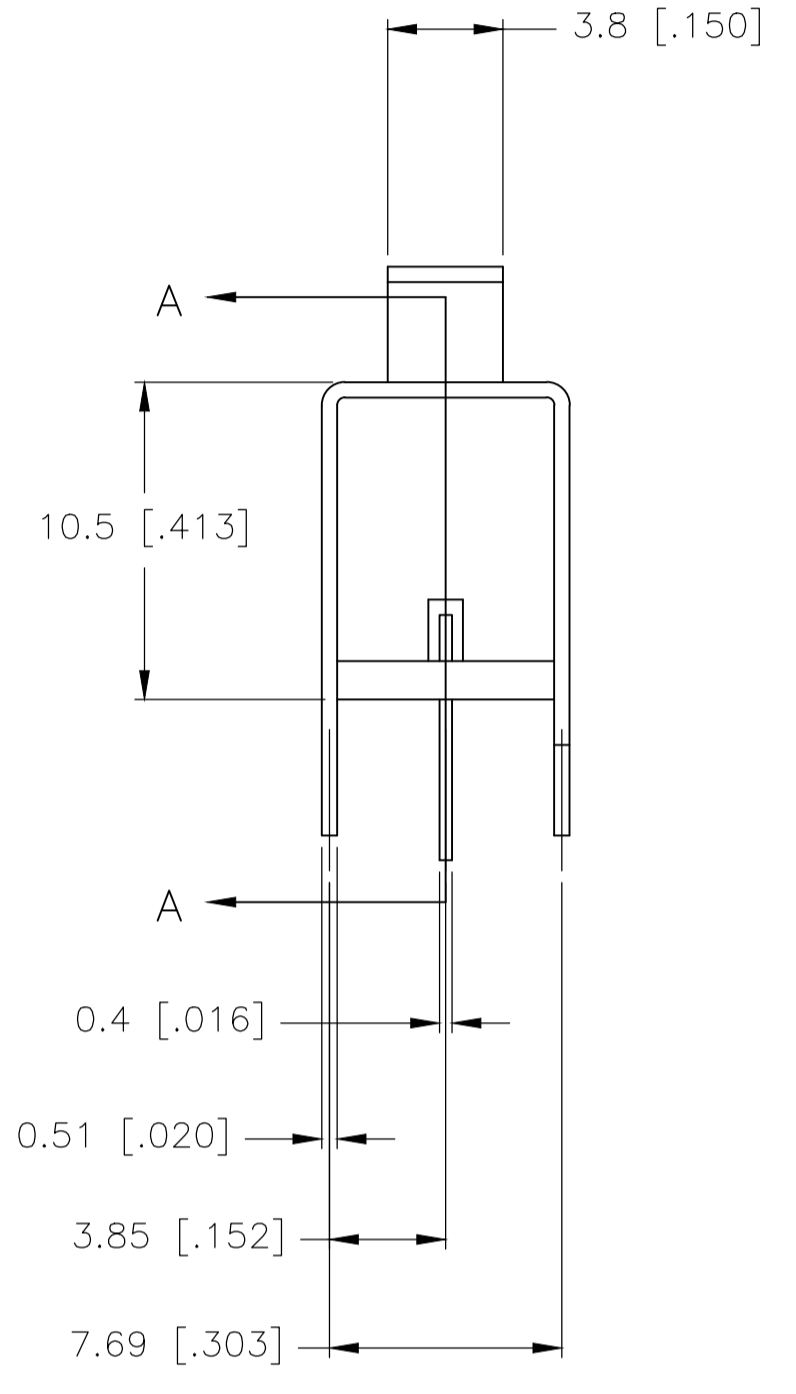

SECTION A-A

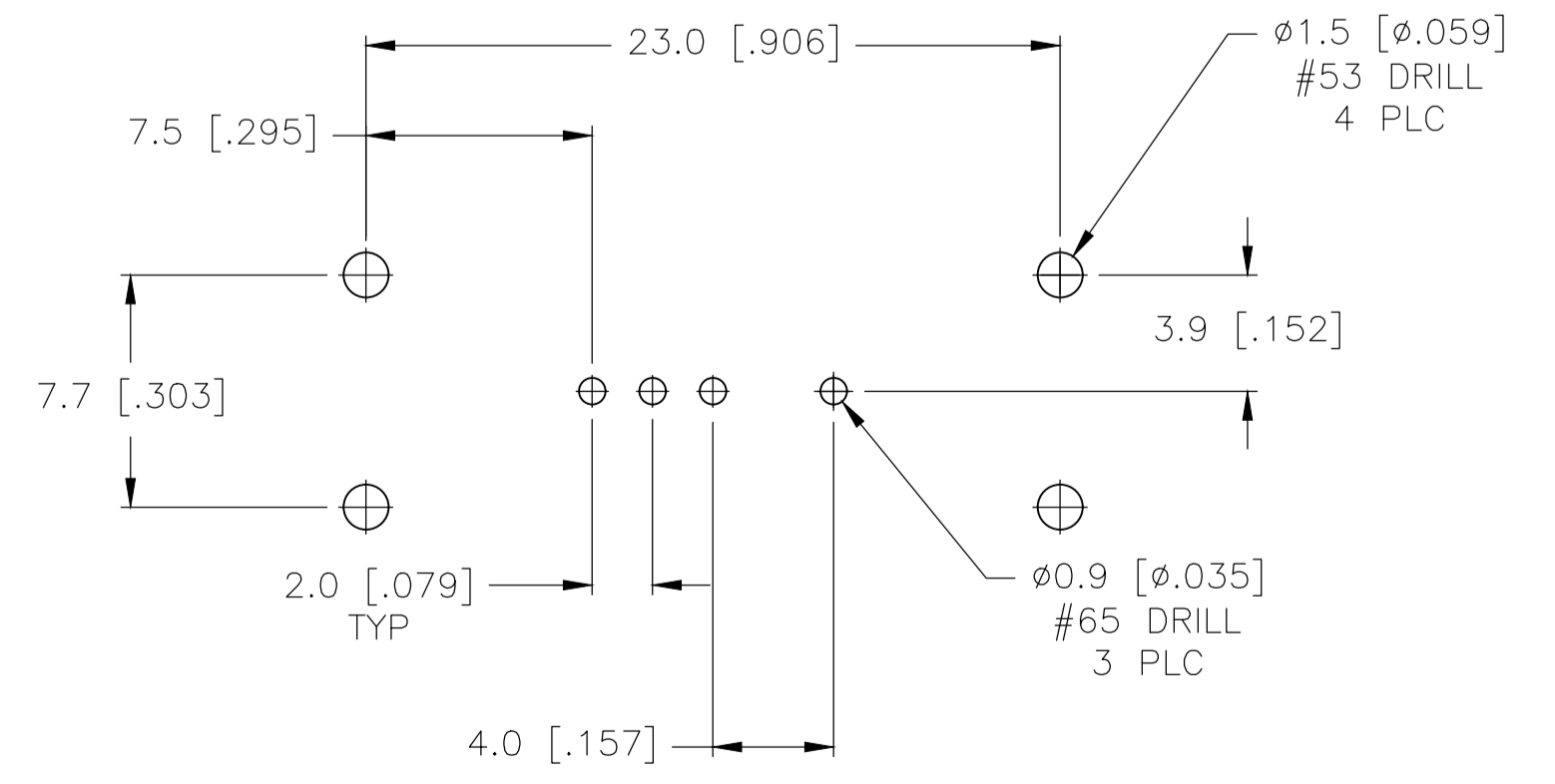

RECOMMENDED BOARD LAYOUT

1825259-2	MSS1300G04	GOLD	3 TO 1	3 TO 2	3 TO 4
OBSOLETE	1825259-1	MSS130004	SILVER	3 TO 1	3 TO 2
TE PART NO.	T&B PART NO.	PLATING			
TERMINALS CONNECTED WHEN SLIDE IS IN POSITION SHOWN.					

THIS DRAWING IS A CONTROLLED DOCUMENT. DIN R BROWN 20DEC05. CHK M SARVER 20DEC05. APVD M SARVER 20DEC05. NAME: SLIDE SWITCH, MSS 1300 SERIES, SP-3T, VERTICAL.

DIMENSIONS:	TOLERANCES UNLESS OTHERWISE SPECIFIED:	SIZE	CAGE CODE	DRAWING NO	RESTRICTED TO
mm	0 PLC ± - 1 PLC ± - 2 PLC ± 0.3 [0.12] 3 PLC ± - 4 PLC ± - ANGLES ± -	A1	00779	1825259	-

MATERIAL: FINISH: WEIGHT: SCALE: 4:1 SHEET 1 OF 1 REV A2