

## Specific CAN-controlled brushless motor evaluation board based on SPC560P and L9908



### Features

- Hosts an automotive-grade **L9908** gate driver to control 6 N-channel FETs and **SPC560P** Pictus 32-bit automotive microcontroller
- Works with 12 V, 24 V and 48 V battery bus
- Independent encoder inputs and Hall sensors
- Gate driver configurable through dedicated SPI bus
- CAN bus interface for remote control

### Description

The **AEK-MOT-3P99081** evaluation board is based on the **SPC560P** Pictus 32-bit MCU and the **L9908** gate driver allowing the control of 6 N-channel FETs for brushless motors in automotive applications.

The **AEK-MOT-3P99081** supports independent encoder inputs and Hall sensors to detect and control motor speed.

The **L9908** independently controls each N-channel FET through a dedicated PWM input pin. **L9908** configuration, protection and diagnostic functions are controlled via SPI by the **SPC560P** microcontroller.

Firmware is preloaded and can be externally driven via CAN bus. The **STSW-AUTODEVKIT** contains a CAN bus driving example based on **SPC58** Chorus 4M, named "SPC58ECxx\_RLA\_MainEcuForBLDCControl-L9908 - Test Application". In the project folder, a readme file explains how to use the demo which works only with a BLDC motor with Hall sensors.

To change the motor characteristics or the control firmware on the **SPC560P50L5**, you need to install the **SPC5-MCTK-LIB** motor control plug-in in **SPC5-STUDIO**.

Once the motor control plug-in is installed, select the "SPC560Pxx\_RLA\_AEK\_MOT\_3P99081\_3Phase\_Motor\_Control\_L9908\_via\_CAN" demo and make your customizations in the Motor Control Component section.

Update the Motor Settings section according to the motor used and, if the motor sensing is not based on Hall sensors, update also the type of sensor used in the Speed Sensor Selection menu of the Drive Management section.

Product summary	
Evaluation board based on SPC560P Pictus 32-bit MCU and L9908 gate driver	<b>AEK-MOT-3P99081</b>
AutoDevKit library plugin for SPC5-STUDIO	<b>STSW-AUTODEVKIT</b>
Code Generator, Quick resources configurator and Eclipse development environment for SPC5 MCUs	<b>SPC5-STUDIO</b>
32-bit Power Architecture MCU for Automotive Chassis and Safety Applications	<b>SPC560P50L5</b>
Applications	Motor Control

# 1 Block diagram

Figure 1. AEK-MOT-3P99081 block diagram

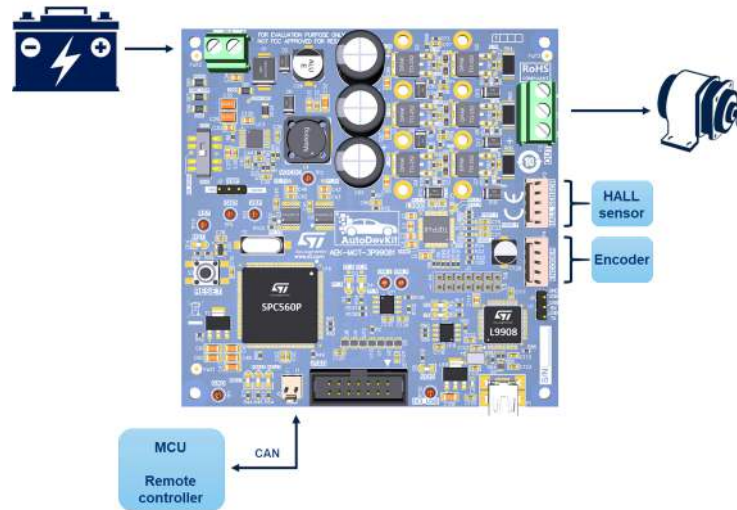

## 2 Schematic diagrams

Figure 2. AEK-MOT-3P99081 circuit schematic (1 of 5)

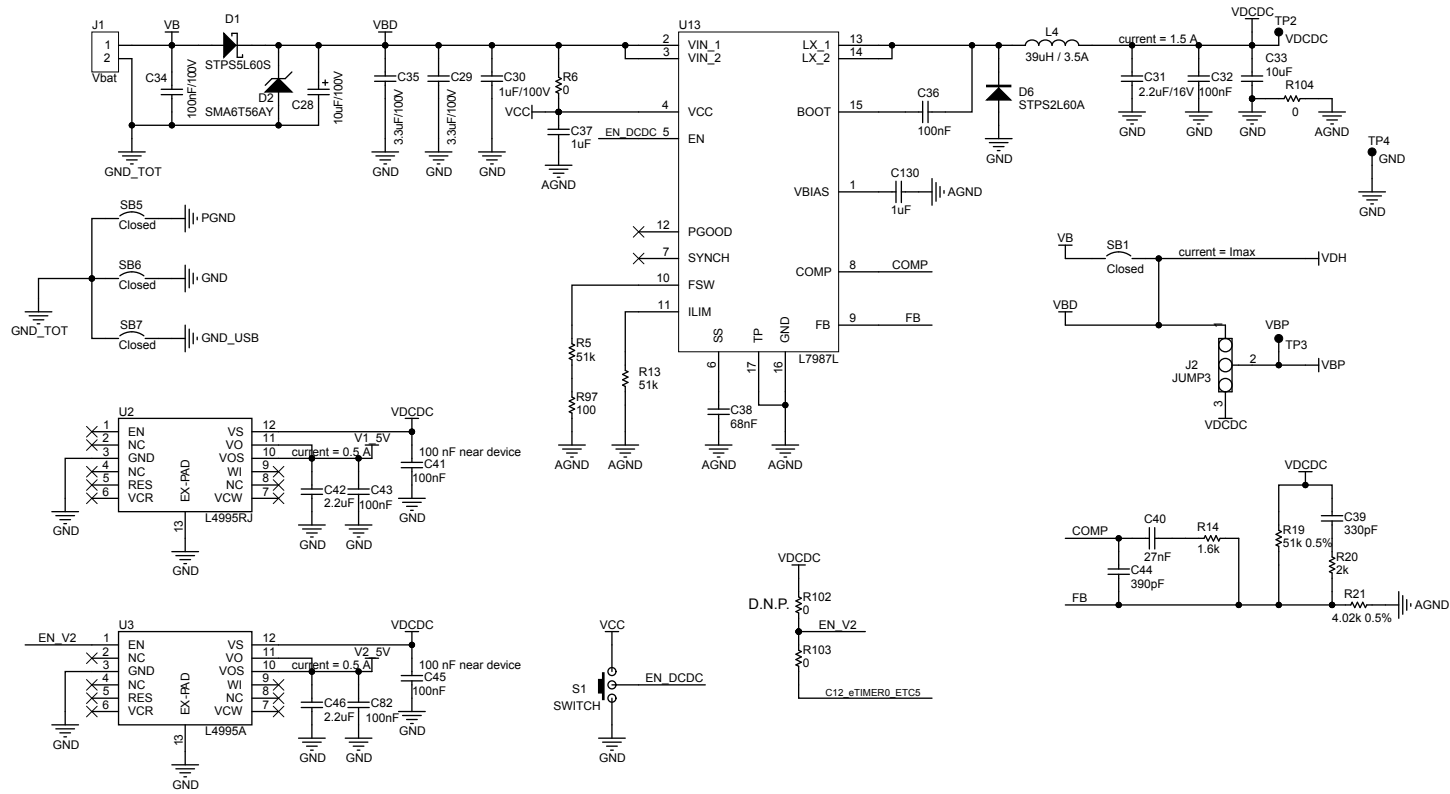

Figure 3. AEK-MOT-3P99081 circuit schematic (2 of 5)

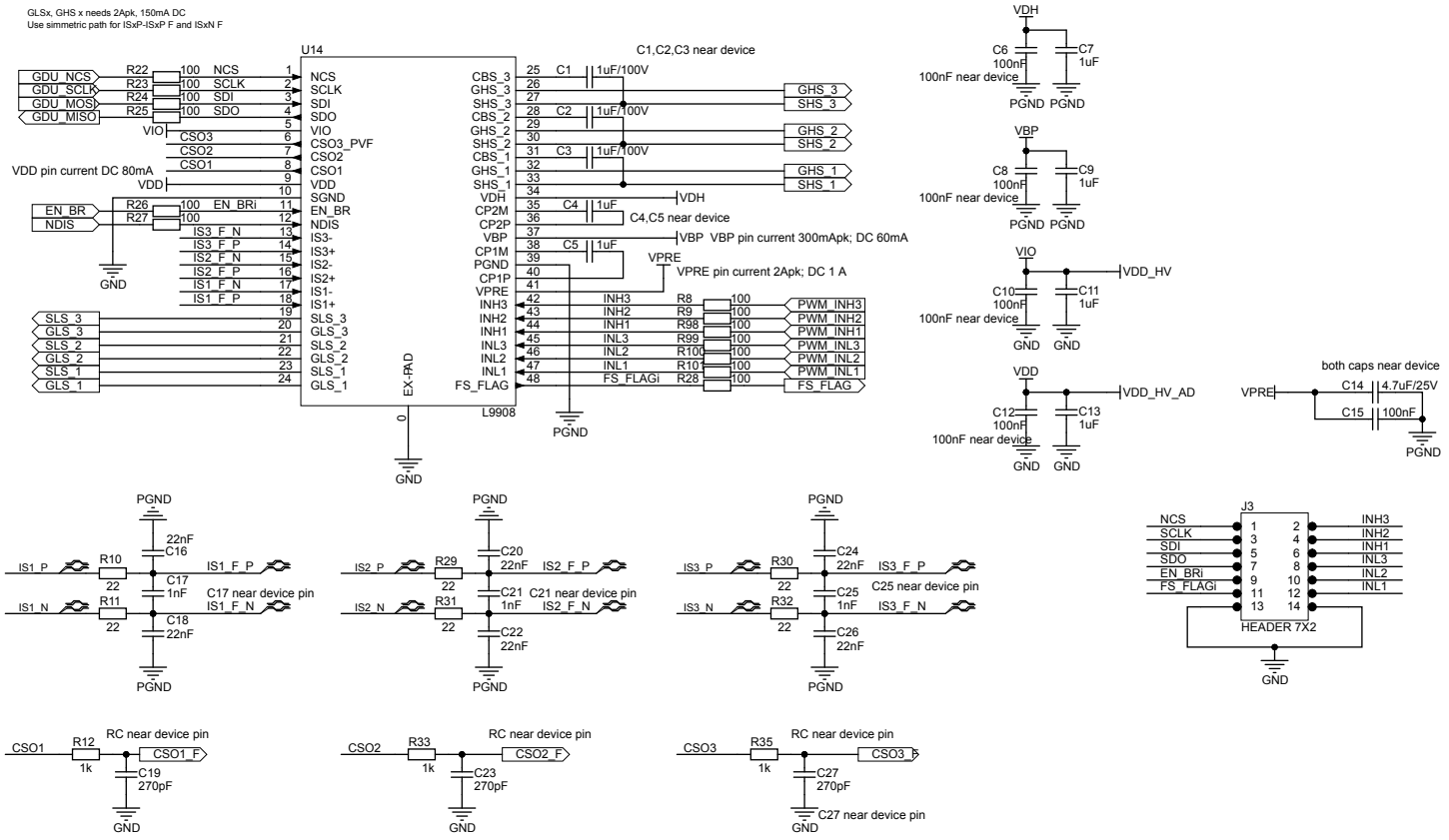



Figure 5. AEK-MOT-3P99081 circuit schematic (4 of 5)

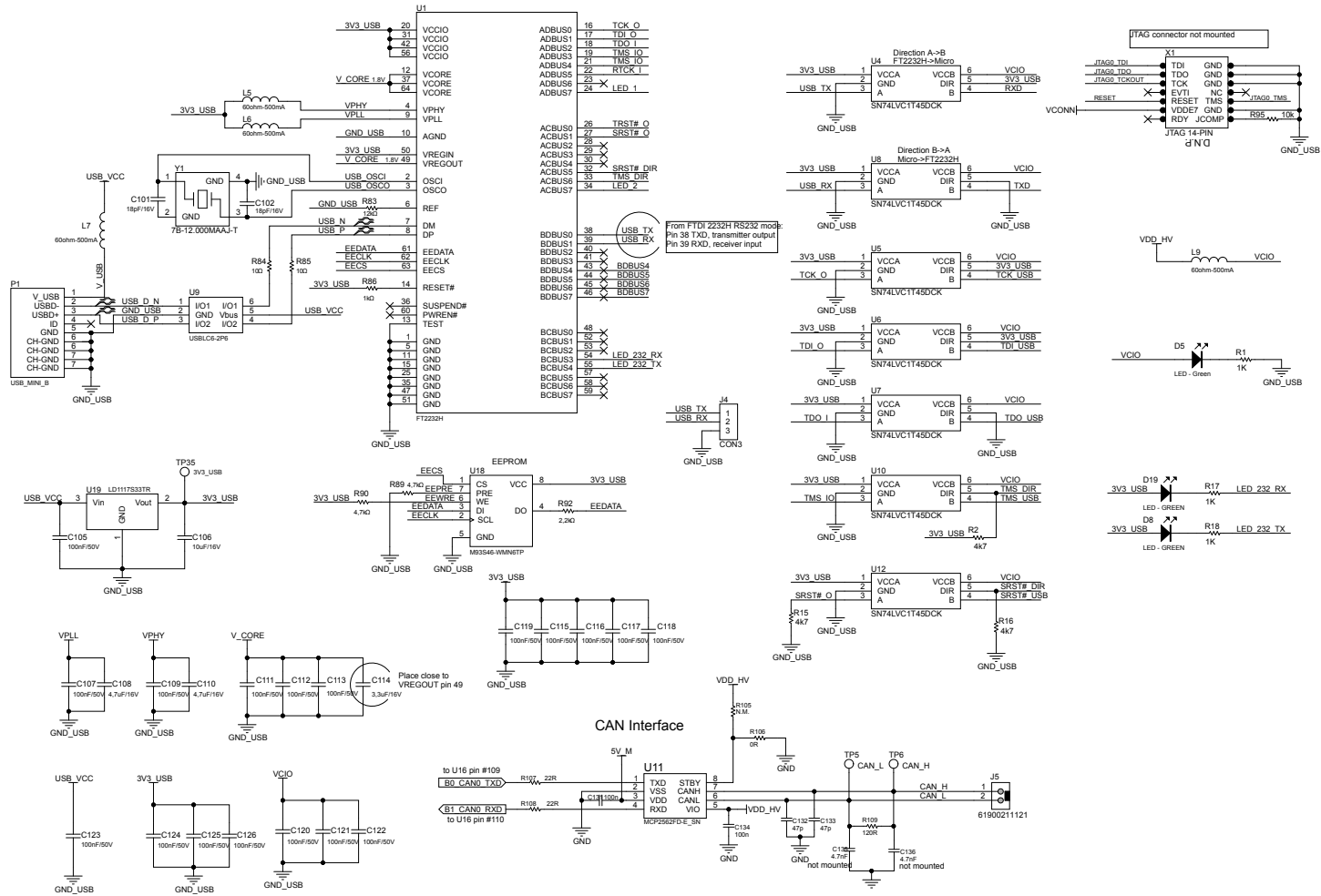
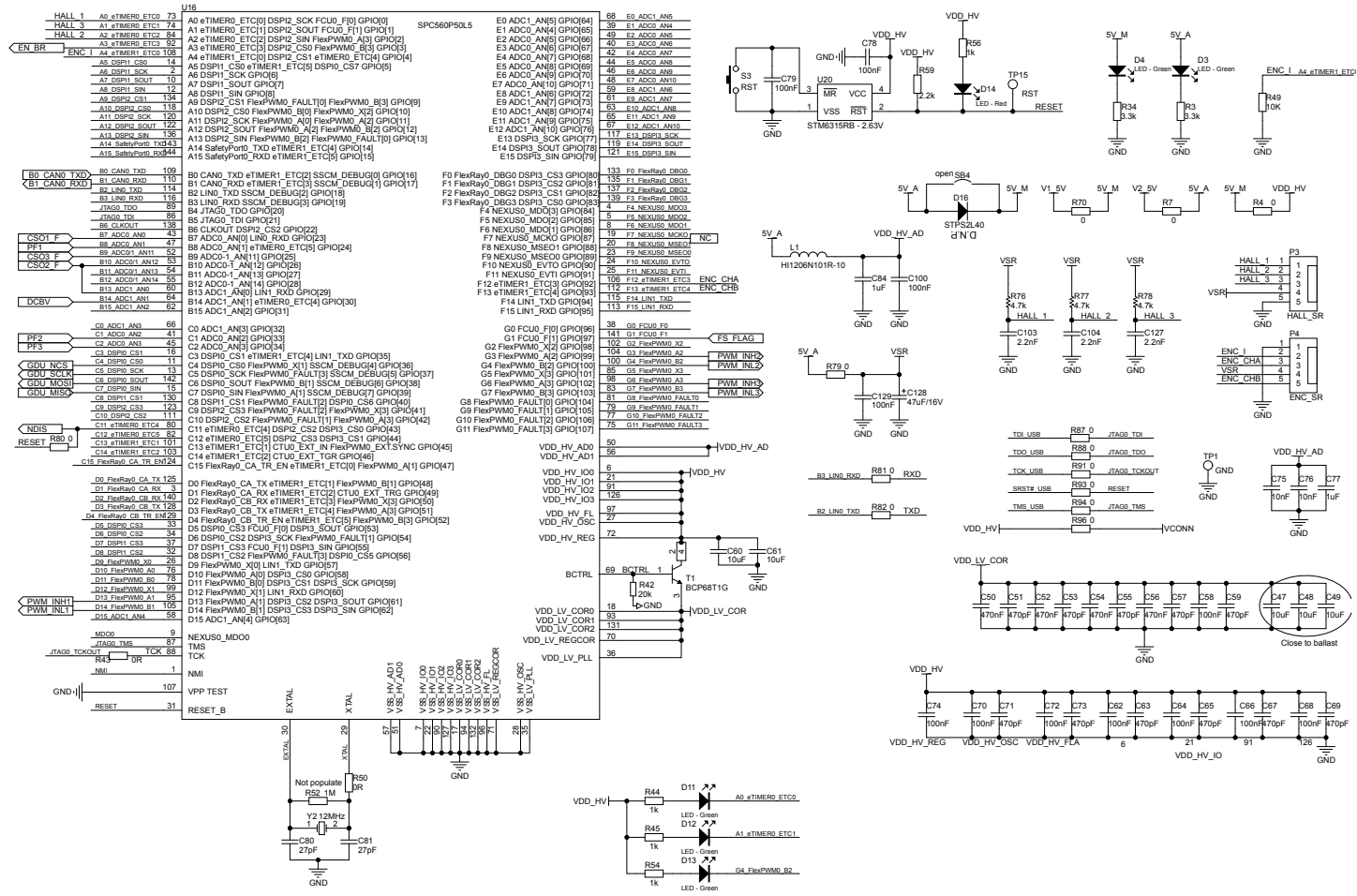

Figure 6. AEK-MOT-3P99081 circuit schematic (5 of 5)



## Revision history

**Table 1. Document revision history**

Date	Revision	Changes
08-Sep-2021	1	Initial release.
13-Sep-2021	2	Updated cover page features and description.



**IMPORTANT NOTICE – PLEASE READ CAREFULLY**

STMicroelectronics NV and its subsidiaries (“ST”) reserve the right to make changes, corrections, enhancements, modifications, and improvements to ST products and/or to this document at any time without notice. Purchasers should obtain the latest relevant information on ST products before placing orders. ST products are sold pursuant to ST’s terms and conditions of sale in place at the time of order acknowledgement.

Purchasers are solely responsible for the choice, selection, and use of ST products and ST assumes no liability for application assistance or the design of Purchasers’ products.

No license, express or implied, to any intellectual property right is granted by ST herein.

Resale of ST products with provisions different from the information set forth herein shall void any warranty granted by ST for such product.

ST and the ST logo are trademarks of ST. For additional information about ST trademarks, please refer to [www.st.com/trademarks](http://www.st.com/trademarks). All other product or service names are the property of their respective owners.

Information in this document supersedes and replaces information previously supplied in any prior versions of this document.

© 2021 STMicroelectronics – All rights reserved