

SIDE VIEW OF BOX

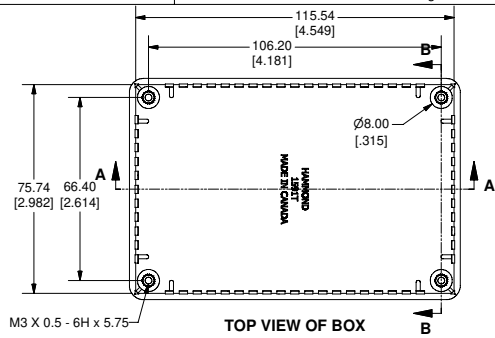

TOP VIEW OF BOX

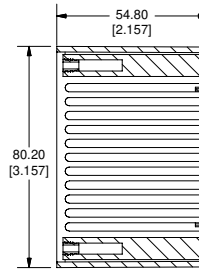

SECTION B-B

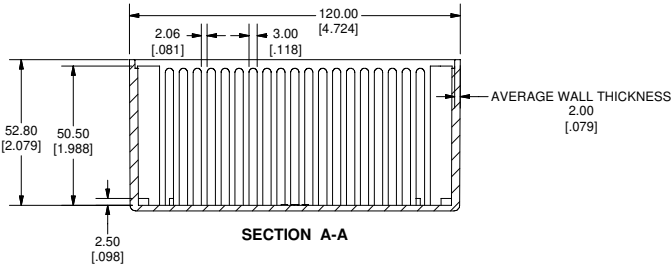

SECTION A-A

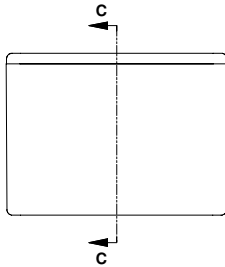

SIDE VIEW OF ASSEMBLY

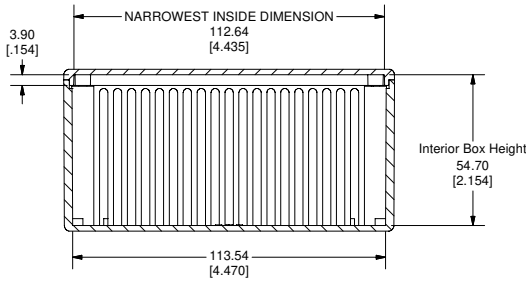

SECTION C-C

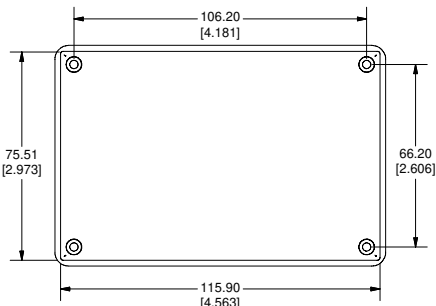

BOTTOM OF LID

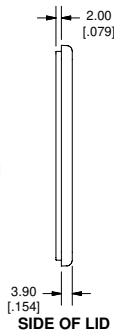

SIDE OF LID

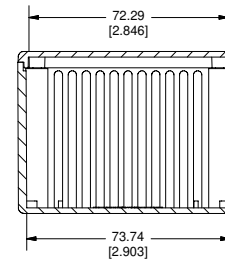
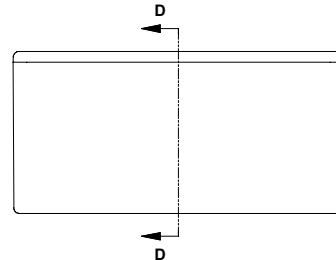

SECTION D-D

Note:  
Enclosures can be Factory Modified ( Milling, Drilling, Printing etc. )  
Contact Factory [mjm@hammondmfg.com](mailto:mjm@hammondmfg.com) for quotes  
Solid models of this enclosure available in STEP or IGES Format.

PART NUMBERS		
1591T Enclosures		
Material	Colour	Part Number
FR ABS UL94 - V0	Beige	1591TBG
	Black	1591TBK
	Blue	1591TBU
GP ABS	Grey	1591TGY
	Black	1591TSBK
	Grey	1591TSGY
Accessories		
Description	Part Number	
Universal Use	PC Board Card Adapters	See Accessories Section
	Clear Lids - clear, flame retardant polycarbonate - Lid ONLY	1591TC
FR ABS	Replacement Screws, Flat Head Phillips Nickel Plated Pkg of 100	1591MS100 (Black)
GP ABS	Self Tapping Pkg of 100	1591TS100 (Black)
Recommended Torque on Fasteners (no lubrication)		
	M3 - 0.5 x 10mm Screws	30-40 cN*m
	#4 x 0.5 Screws	30-40 cN*m

