

MATERIALS & FINISHES

BODY, CRIMP TUBE: BRASS  
PLATED GOLD

CONTACT: BERYLLIUM COPPER  
PLATED GOLD

INSULATOR: TEFLON

O-RING: SILICONE RUBBER

JAM NUT (SEE TABLE): BRASS  
PLATED GOLD

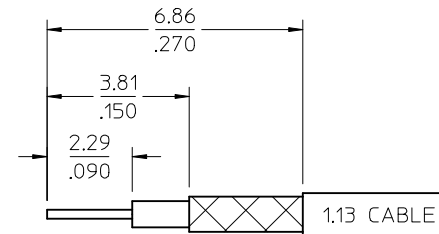
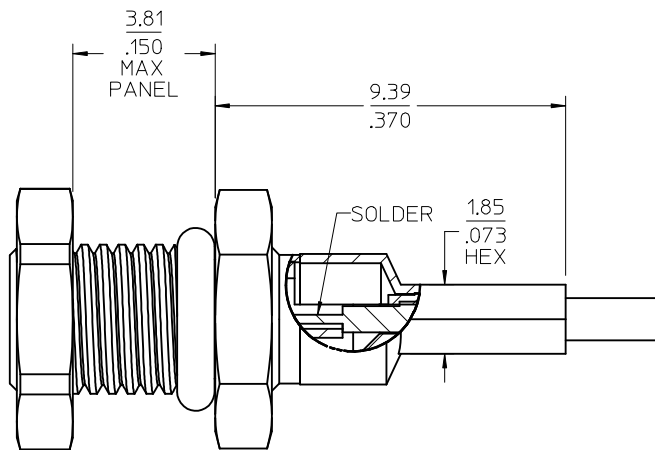
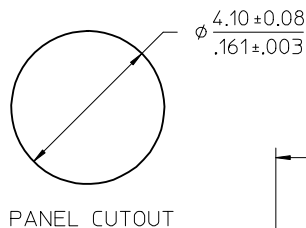
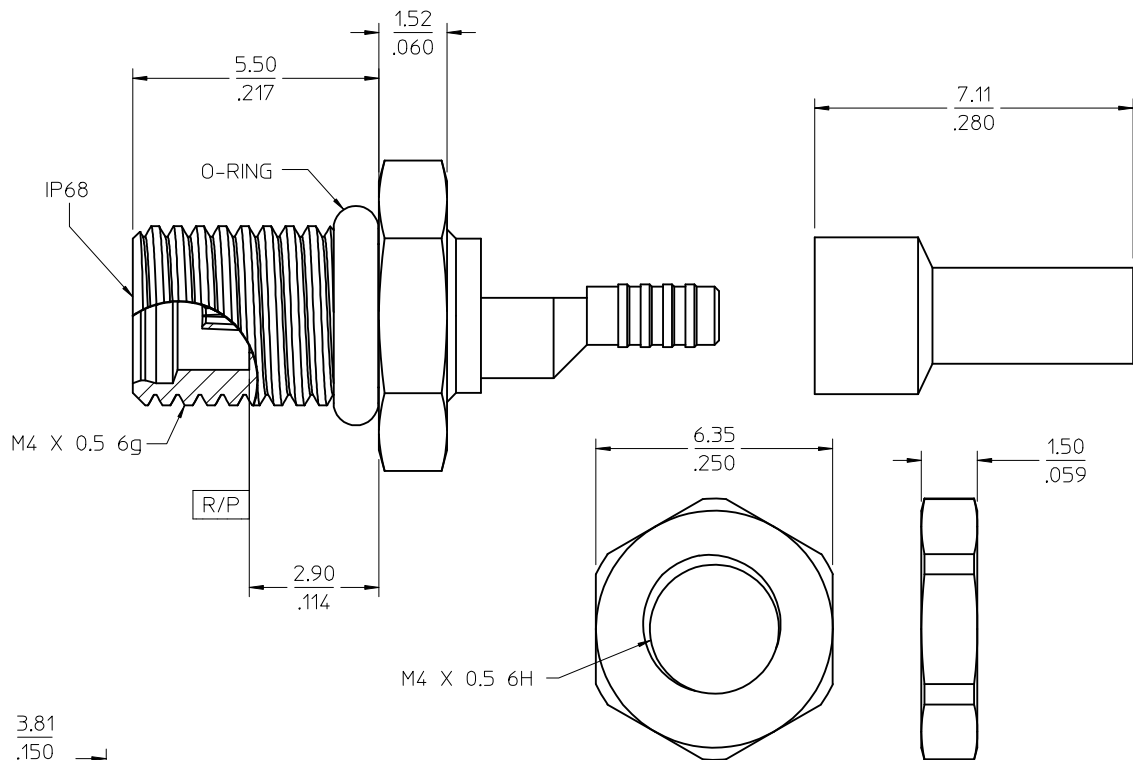
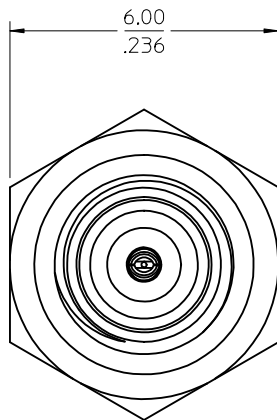
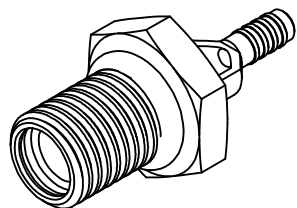

73414-6113	NOT INCLUDED	NOT INCLUDED
73414-6112	INCLUDED	NOT INCLUDED
73414-6111	NOT INCLUDED	INCLUDED
73414-6110	INCLUDED	INCLUDED
PART NO.	JAM NUT	O RING

PS-89675-1920	PRODUCT SPECIFICATION
CECC-22-340	INTERFACE
SPECIFICATION	DESCRIPTION

CHG:ADD PART NO. 73414-6113 EWR RF13-061 EC NO: URF2013-0290 DRWN:YCHENG 2012/11/20 CHKD: APPR:MHUANG 2012/12/01 A3	QUALITY SYMBOLS ▽=0 ▽=0	GENERAL TOLERANCES (UNLESS SPECIFIED) mm INCH 4 PLACES ± --- ± --- 3 PLACES ± --- ± --- 2 PLACES ± --- ± --- 1 PLACE ± --- ± --- ANGULAR ± 2 °		DIMENSION STYLE MM/IN	SCALE DESIGN UNITS METRIC	THIRD ANGLE PROJECTION
		DRAWN BY DATE AROBERTSON 2011/04/01		TITLE MMCX JACK ST BLK RM IP68 O-RING 50 OHM 1.13 CABLE MMCX-JC, EWR-4671		
		CHECKED BY DATE SSS 2011/04/01		APPROVED BY DATE JWIENER 2011/04/13		
		MATERIAL NO. SEE TABLE		DOCUMENT NO. SD-73414-611		
DRAFT WHERE APPLICABLE MUST REMAIN WITHIN DIMENSIONS				SIZE C	SHEET NO. 1 OF 1	
THIS DRAWING CONTAINS INFORMATION THAT IS PROPRIETARY TO MOLEX INCORPORATED AND SHOULD NOT BE USED WITHOUT WRITTEN PERMISSION						