

PROJEKT NR.: PRJ-14-00000805		REVISIONS ÄNDERUNGEN		
P	LTR	DESCRIPTION BESCHREIBUNG	DATE	DWN APVD
	A2	DESCRIPTION CORRECTED FROM SOLDER TO SCREW TERMINAL IN TITLE BLOCK	13NOV2014	CR JK

1 MATERIAL: ITEM NO. 1: HOUSING - ZINC DIE CASTING, NICKEL PLATED  
 ITEM NO. 2: CONTACT BODY - PA66  
 ITEM NO. 3: CONTACT - CuSn  
 CONTACT FINISH - Au

- 2 ALL DIMENSIONS ARE FOR NOMINAL REFERENCE ONLY UNLESS OTHERWISE STATED
- 3 MEASUREMENT REFERENCE ONLY
- 4 PACKAGING: 1 PIECE IN A BAG

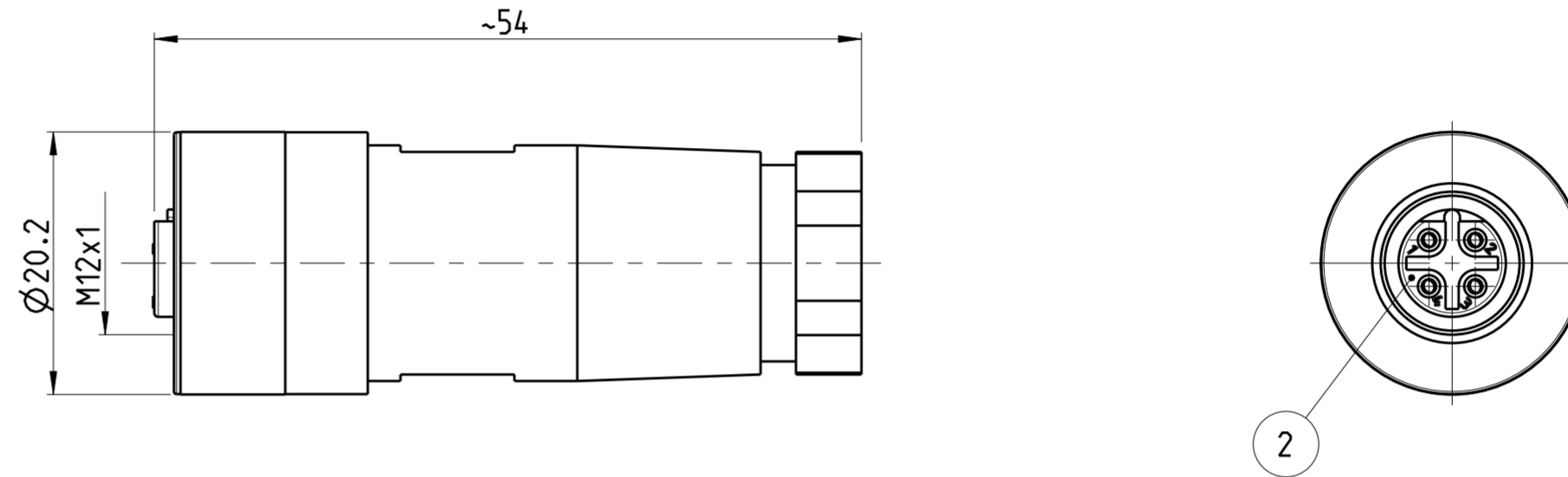

TECHNICAL DATA	3-2271118-1	3-2271118-2	4-2271118-1	4-2271118-2
RATED VOLTAGE	250V	250V	125V	125V
RATED IMPULSE VOLTAGE	2500V	2500V	1500V	1500V
POLLUTION DEGREE	3	3	3	3
OVERVOLTAGE CATEGORY	II	II	II	II
MATERIAL GROUP	II	II	II	II
RATED CURRENT	4A	4A	4A	4A
VOLUME RESISTIVITY	≤ 3mΩ	≤ 3mΩ	≤ 3mΩ	≤ 3mΩ
DEGREE OF PROTECTION	IP68	IP68	IP68	IP68
UPPER TEMPERATURE	+85 °C	+85 °C	+85 °C	+85 °C
LOWER TEMPERATURE	-40 °C	-40 °C	-40 °C	-40 °C

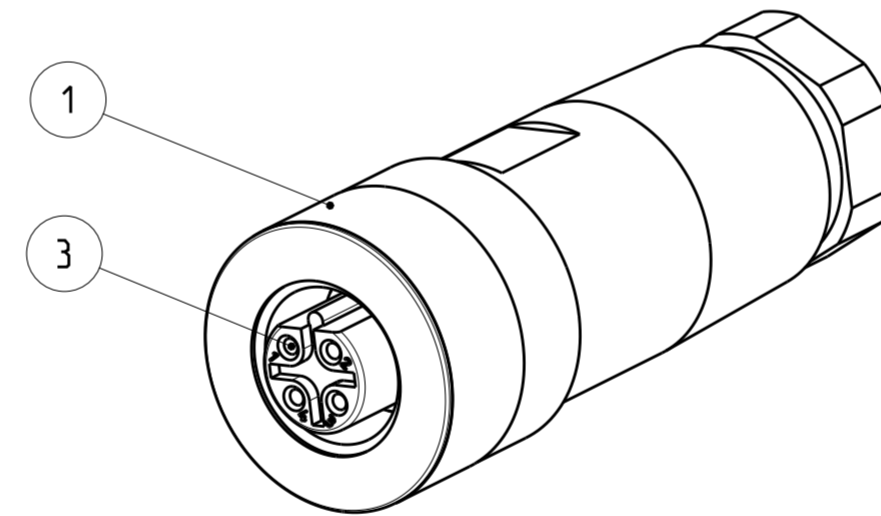

3-2 AS SHOWN  
WIE GEZEICHNET

PIN ARRANGEMENT  
B-CODING

3-2271118-1	3-2271118-2	4-2271118-1	4-2271118-2

6-8	24 / 0.25mm <sup>2</sup>	⚠	5	4-2271118-2
4-6	24 / 0.25mm <sup>2</sup>	⚠	5	4-2271118-1
6-8	24 / 0.25mm <sup>2</sup>	⚠	4	3-2271118-2
4-6	24 / 0.25mm <sup>2</sup>	⚠	4	3-2271118-1
CABLE FEED-THROUGH mm	WIRES AWG / mm <sup>2</sup>	MATERIAL	NUMBER OF POLES	TE-PART-NO.

DIESE ZEICHNUNG IST EIN KONTROLLIERTES DOKUMENT.  
BEMASSUNGEN UND TOLERANZEN GEMAESS GPS (ISO STANDARDS).

THIS DRAWING IS A CONTROLLED DOCUMENT.  
DIMENSIONING AND TOLERANCING PER GPS (ISO STANDARDS).

DIMENSIONS: MASSEINHEITEN: [mm]	TOLERANCES UNLESS OTHERWISE SPECIFIED: ALLGEMEINTOLERANZEN:	DWN YASHKUMAR 14MAY2014 CHK M.STRELOW 14MAY2014 APVD C.SCHREITLINGER 14MAY2014	NAME M12 RECEPTACLE, STRAIGHT, FIELD INSTALLABLE, UNSHIELDED CONNECTOR, SCREW TERMINALS, B-CODING
MATERIAL	ANGLES/WINKEL ± FINISH/OBERFLAECHE/FARBE	PRODUCT SPEC 108-19483 APPLICATION SPEC 114-32127	SIZE A2 CAGE CODE 00779 DRAWING NO. C-2271118 RESTRICTED TO NUR FUER -
		WEIGHT GEWICHT	SCALE MASSSTAB 2:1 SHEET BLATT 1 OF 1 REV A2

Customer Drawing /KUNDENZEICHNUNG

SIZE ISO 14405 (E)