

Description

The PT7A7611-7615/7621-7625/7631-7635 family micro-processor (μP) supervisory circuits are targeted to improve reliability and accuracy of power-supply circuitry in μP's systems. These devices reduce the complexity and number of components required to monitor power-supply and battery functions.

The main functions are:

1. Asserting reset output during power-up, power-down and brownout conditions for μP system.
2. Detecting power failure or low-battery conditions with a 1.25V threshold detector.
3. Watchdog functions (not for PT7A7631-7635).

Features

- Precision Supply-voltage Monitor
 - 4.63V (PT7A7611/7621/7631)
 - 4.38V (PT7A7612/7622/7632)
 - 3.08V (PT7A7613/7623/7633)
 - 2.93V (PT7A7614/7624/7634)
 - 2.63V (PT7A7615/7625/7635)
- 200ms Reset Pulse Width
- Debounced TTL/CMOS-compatible Manual-reset Input
- Independent Watchdog Timer 1.6sec Time-out (Not Available for PT7A7631-7635)
- Voltage Monitor for Power-fail or Low Battery Warning
- Reset Output Signal:
 - Active-low Only (PT7A7611-7615)
 - Active-high Only (PT7A7621-7625)
 - Active-high and Active-low (PT7A7631-7635)
- Guaranteed RESET/RESET Valid at $V_{CC} = 1V$
- **Totally Lead-Free & Fully RoHS Compliant (Notes 1 & 2)**
- **Halogen and Antimony Free. "Green" Device (Note 3)**

Pin Assignments

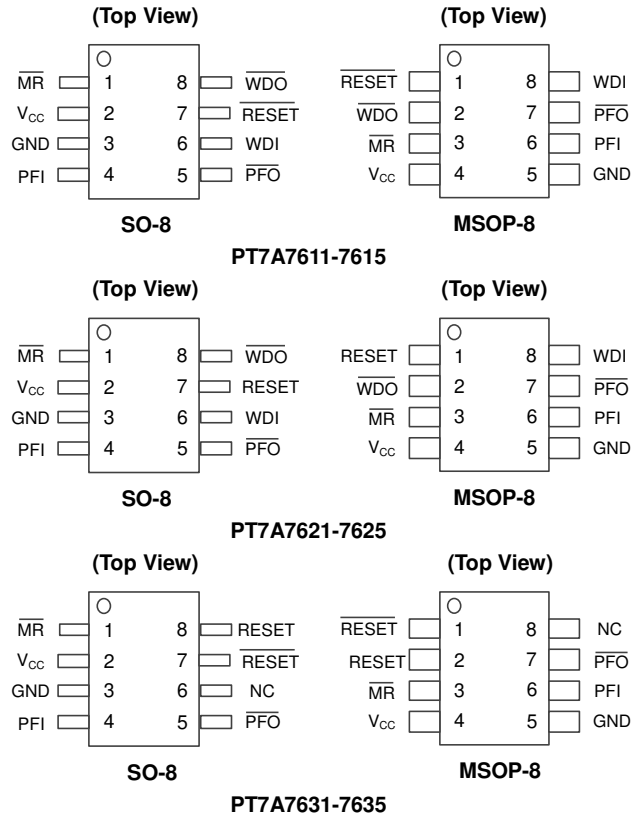

Applications

- Computers
- Controllers
- Intelligent Instruments
- Critical μP and μC Power Monitoring
- Portable/Battery Powered Equipment

Notes:

1. No purposely added lead. Fully EU Directive 2002/95/EC (RoHS), 2011/65/EU (RoHS 2) & 2015/863/EU (RoHS 3) compliant.
2. See <https://www.diodes.com/quality/lead-free/> for more information about Diodes Incorporated's definitions of Halogen- and Antimony-free, "Green" and Lead-free.
3. Halogen- and Antimony-free "Green" products are defined as those which contain <900ppm bromine, <900ppm chlorine (<1500ppm total Br + Cl) and <1000ppm antimony compounds.

Typical Applications Circuit

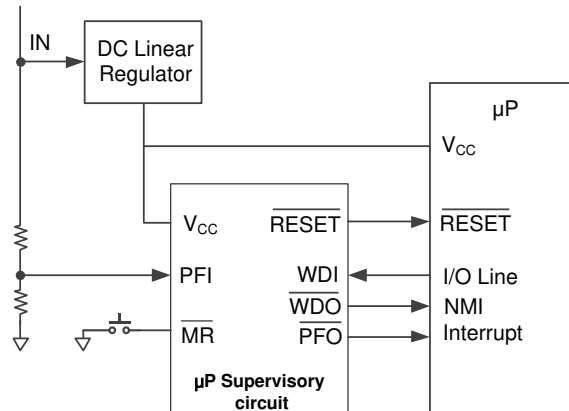

Figure 1. Typical Application Diagram

Pin Descriptions

Pin Number						Pin Name	Description
PT7A7611-7615		PT7A7621-7625		PT7A7631-7635			
SO-8	MSOP-8	SO-8	MSOP-8	SO-8	MSOP-8		
1	3	1	3	1	3	$\overline{\text{MR}}$	Manual-Reset: triggers a reset pulse when pulled below 0.8V, active low. It has an internal 250µA pull-up current and be driven from a TTL or CMOS logic line as well as shorted to ground with a switch.
2	4	2	4	2	4	V _{CC}	Supply Voltage.
3	5	3	5	3	5	GND	Ground Reference for all signals.
4	6	4	6	4	6	PFI	Power-Fail Voltage Monitor Input. When PFI is less than 1.25V, $\overline{\text{PFO}}$ goes low. Connect PFI to GND or V _{CC} when not used.
5	7	5	7	5	7	$\overline{\text{PFO}}$	Power-Fail Output: it gets low and sinks current when PFI is less than 1.25V; otherwise $\overline{\text{PFO}}$ stays high.
6	8	6	8	—	—	WDI	Watchdog Input: If WDI remains high or low for 1.6sec, the internal watchdog timer runs out and WDO goes low. Floating WDI or connecting WDI to a high-impedance three-state buffer disables the watchdog feature. The internal watchdog timer clears whenever reset is asserted. WDI is three-stated, or WDI sees a rising or falling edge.
—	—	—	—	6	8	NC	Not Connected.
7	1	—	—	7	1	$\overline{\text{RESET}}$	Reset Output pulses: low for 200ms when triggered, and stays low whenever V _{CC} is below the reset threshold. It remains low for 200ms after V _{CC} rises above the reset threshold or $\overline{\text{MR}}$ goes from low to high. A watchdog timeout will not trigger $\overline{\text{RESET}}$ unless WDO is connected to $\overline{\text{MR}}$.
8	2	8	2	—	—	$\overline{\text{WDO}}$	Watchdog Output: pulls low when the internal watchdog timer finishes its 1.6sec count and does not go high again until the watchdog is cleared. WDO also goes low during low-line conditions. Whenever V _{CC} is below the reset threshold, WDO stays low; however, unlike $\overline{\text{RESET}}$, WDO does not have minimum pulse width. As soon as V _{CC} rises above the reset threshold, WDO goes high with no delay.
—	—	7	1	8	2	RESET	The inverse of RESET, active high. Whenever RESET is high, RESET is low.

NEW PRODUCT

Functional Block Diagram

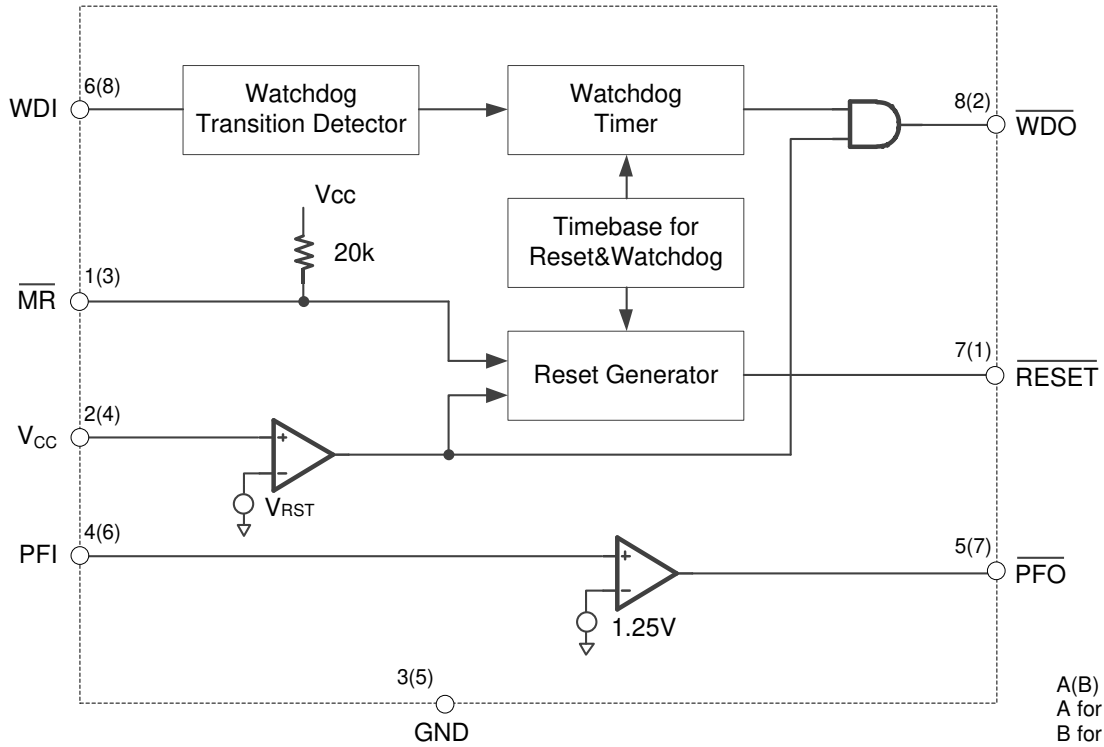

Block Diagram of PT7A7611-7615

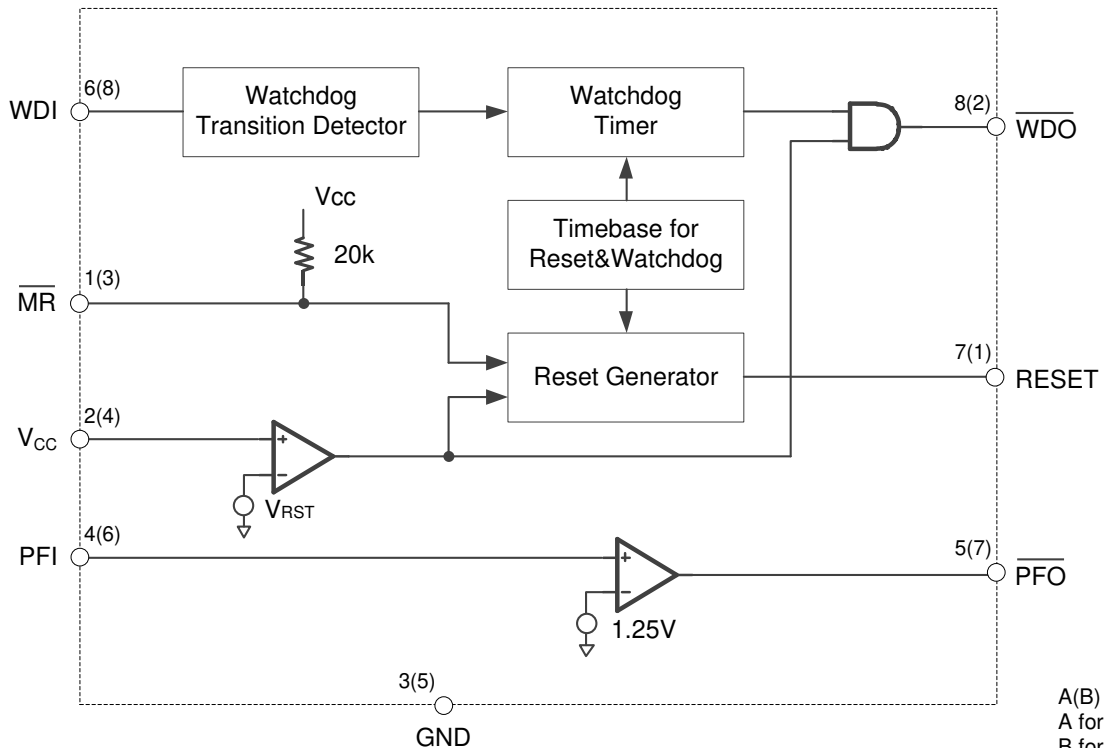

Block Diagram of PT7A7621-7625

Functional Block Diagram (Cont.)

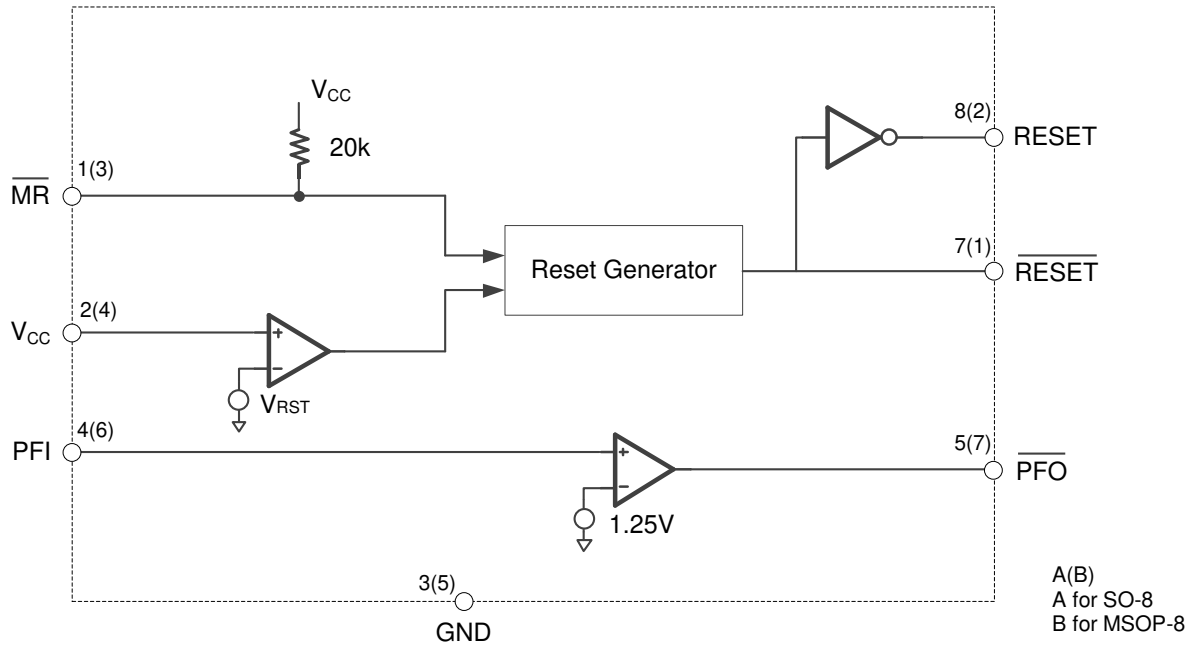

Block Diagram of PT7A7631-7635

Maximum Ratings (Note 4)

Parameter	Rating	Unit
Supply Voltage to Ground Potential (V_{CC} to GND)	-0.3 to +6.0	V
DC Input Voltage (All inputs except V_{CC} and GND)	-0.3 to $V_{CC}+0.3$	V
DC output Current (All Output)	20	mA
Power Dissipation (Depend on Package)	500	mW
Ambient Temperature with Power Applied	-40 to +85	°C
Storage Temperature Range	-65 to +150	°C

Note: 4. Stresses greater than those listed under MAXIMUM RATINGS may cause permanent damage to the device. This is a stress rating only and functional operation of the device at these or any other conditions above those indicated in the operational sections of this specification is not implied. Exposure to absolute maximum rating conditions for extended periods may affect reliability.

ESD Ratings

Symbol	Parameter	Rating	Unit
ESD HBM	Human Body Model ESD Protection	2.5	kV
ESD CDM	Charged Device Model ESD Protection	1	kV

Recommended Operating Conditions (@ $T_A = +25^\circ\text{C}$, unless otherwise specified.)

Symbol	Parameter	Min	Typ	Max	Unit
V_{CC}	Supply Voltage for PT7A76x1/76x2	4.5	5.0	5.5	V
	Supply Voltage for PT7A76x3/76x4	3.0	3.3	5.5	V
	Supply Voltage for PT7A76x5	2.7	3.0	5.5	V
T_A	Operating Temperature Range	-40	—	+85	°C

DC Electrical Characteristics ($V_{CC} = V_{RN} + 5\%$ to 5.5V, $T_A = -40$ to $+85^\circ\text{C}$, unless otherwise noted.) (Note 5)

Symbol	Description	Test Conditions	Min	Typ	Max	Unit
I_{CC}	Supply Current	PT7A76x1/76x2 $V_{CC} = 5\text{V}$, PT7A76x3/76x4 $V_{CC} = 3.3\text{V}$, PT7A76x5 $V_{CC} = 3.0\text{V}$, Left WDI unconnected (No output load)	—	10	200	μA
V_{IH}	$\overline{\text{MR}}$ Input High Voltage	$4.5\text{V} < V_{CC} < 5.5\text{V}$ $V_{RST(\text{MAX})} < V_{CC} < 3.6\text{V}$	2.0	—	—	V
	WDI Input High Voltage	$V_{CC} = 5.0\text{V}$ $V_{RST(\text{MAX})} < V_{CC} < 3.6\text{V}$	3.5	—	—	
V_{IL}	$\overline{\text{MR}}$ Input Low Voltage	$4.5\text{V} < V_{CC} < 5.5\text{V}$ $V_{RST(\text{MAX})} < V_{CC} < 3.6\text{V}$	—	—	0.8	V
	WDI Input Low Voltage	$V_{CC} = 5.0\text{V}$ $V_{RST(\text{MAX})} < V_{CC} < 3.6\text{V}$	—	—	0.8	
V_{RST}	Reset Threshold Voltage (Note 6)	—	$V_{RN}-2.0\%$	V_{RN}	$V_{RN}+2.0\%$	V
		PT7A76x1	4.537	4.630	4.723	
		PT7A76x2	4.292	4.380	4.468	
		PT7A76x3	3.018	3.080	3.142	
		PT7A76x4	2.871	2.930	2.989	
V_{HYS}	Reset Threshold Hysteresis (Note 6)	—	—	0.80	—	$\%V_{RN}$
		V_{OH}	Output High Voltage	$4.5\text{V} < V_{CC} < 5.5\text{V}$, $I_{SOURCE} = 800\mu\text{A}$ $V_{RST(\text{MAX})} < V_{CC} < 3.6\text{V}$, $I_{SOURCE} = 500\mu\text{A}$	$V_{CC}-1.5$ $0.8 \times V_{CC}$	—
V_{OL}	Output Low Voltage	$4.5\text{V} < V_{CC} < 5.5\text{V}$, $I_{SINK} = 3.2\text{mA}$	—	—	0.4	V
		$V_{RST(\text{MAX})} < V_{CC} < 3.6\text{V}$, $I_{SINK} = 1.2\text{mA}$	—	—	0.3	
		$V_{CC} = 1.2\text{V}$, $I_{SINK} = 100\mu\text{A}$	—	—	0.3	
V_{PFT}	PFI Input Threshold	PFI falling	1.225	1.250	1.275	V
I_{PFI}	PFI Input Current	—	-1	0.1	+1	μA
I_{WDI}	WDI Input Current (Note 7)	WDI = 0 or V_{CC}	-7	3	+7	μA
R_{MR}	$\overline{\text{MR}}$ Pull-up Resistor	—	—	20	—	$\text{k}\Omega$

Notes: 5. Parameters of room temperature guaranteed by production test and parameters of full-temperature guaranteed by design.

6. Valid for both RESET and $\overline{\text{RESET}}$. V_{RST} is the Reset threshold voltage when V_{CC} from high to low level, V_{RN} is nominal reset threshold voltage.

7. WDI is internally serviced within the watchdog period if WDI is left unconnected.

AC Electrical Characteristics

Symbol	Description	Test Conditions	Min	Typ	Max	Unit
t_{RS}	Reset Pulse Width	—	140	200	280	ms
t_{WD}	Watchdog Timeout Period	—	1.0	1.6	2.25	s
t_{MR}	$\overline{\text{MR}}$ Pulse Width	$4.5\text{V} < V_{CC} < 5.5\text{V}$	150	—	—	ns
		$V_{RST(\text{MAX})} < V_{CC} < 3.6\text{V}$	500	—	—	
t_{MD}	$\overline{\text{MR}}$ to RESET Delay	$4.5\text{V} < V_{CC} < 5.5\text{V}$	—	—	250	ns
		$V_{RST(\text{MAX})} < V_{CC} < 3.6\text{V}$	—	—	750	
t_{WP}	WDI Pulse Width	$4.5\text{V} < V_{CC} < 5.5\text{V}$	50	—	—	ns
		$V_{RST(\text{MAX})} < V_{CC} < 3.6\text{V}$	100	—	—	ns

Timing Diagram

Watchdog Timing Diagram

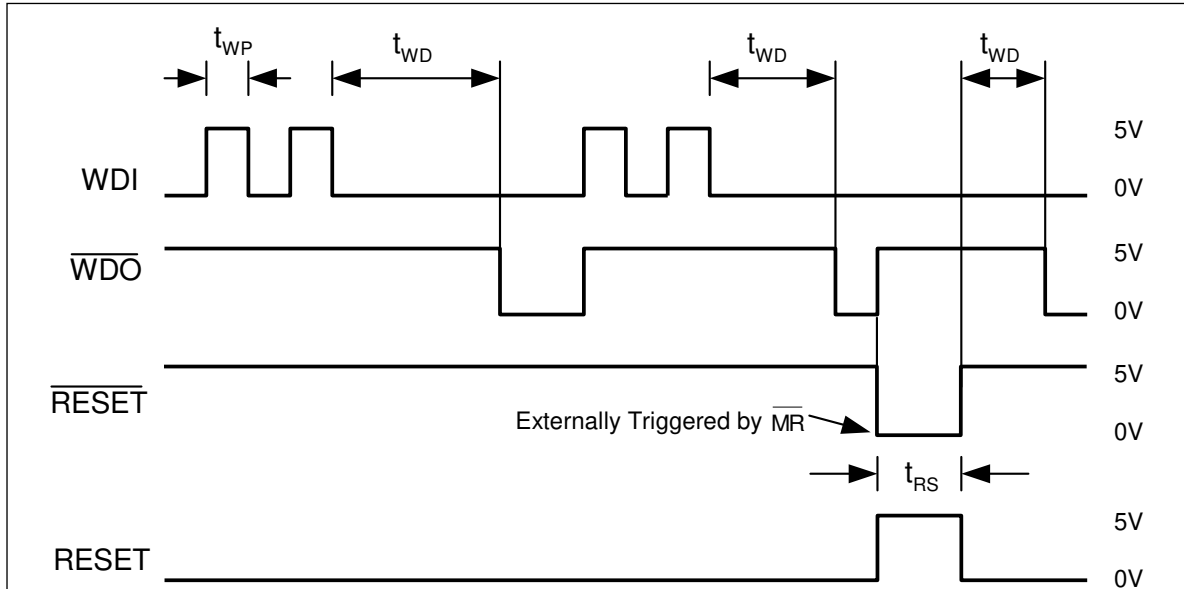
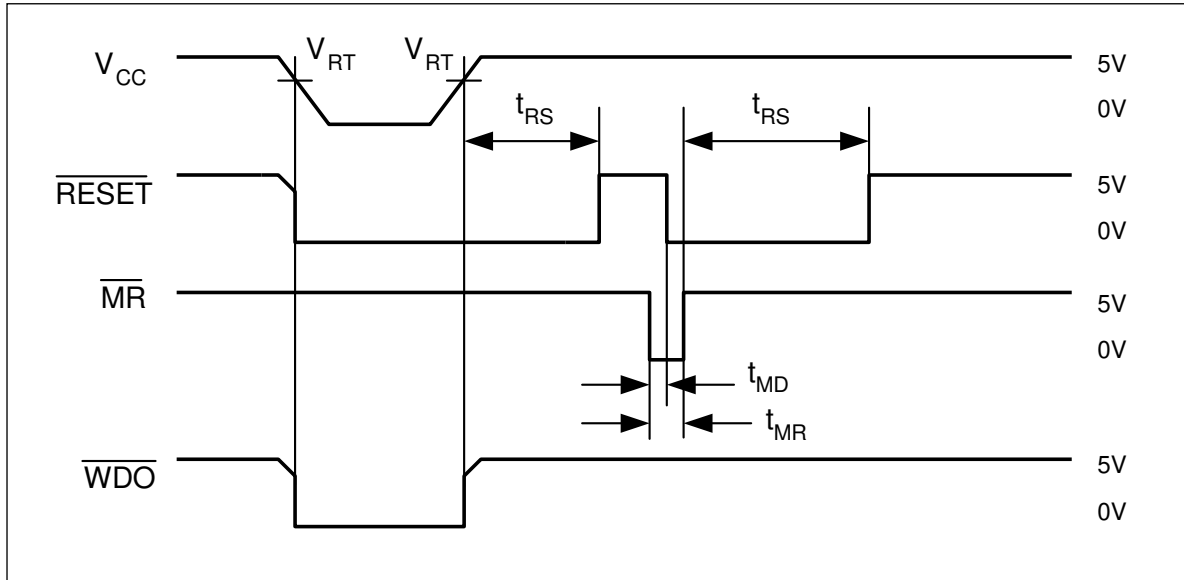

Functional Description

The PT7A7611-7615/7621-7625/7631-7635 family can assert reset output during power-up, power-down and brownout conditions for μ P system, detect power failure or low-battery conditions with a 1.25V threshold detector and have watchdog functions. Refer to Function Comparison Table of PT7A7611-7615/7621-7625/7631-7635 family for their individual features. Figure 1 shows typical application.

Reset Output

The supervisory circuits can assert reset for a microprocessor during power-up, power-down and brownout to prevent code execution errors.

On power-up, once V_{CC} reaches about 1.0V, \overline{RESET} is a guaranteed logic low of 0.4V or less. As V_{CC} rises, \overline{RESET} stays low. When V_{CC} rises above the reset threshold, an internal timer releases \overline{RESET} after about 200ms. \overline{RESET} pulses low whenever V_{CC} drops below the reset threshold, i.e. brownout condition. If brownout occurs in the middle of a previously initiated reset pulse, the pulse continues for at least another 140ms. On power-down, once V_{CC} falls below the reset threshold, \overline{RESET} stays low and is guaranteed to be 0.4V or less until V_{CC} drops below 1.0V.

The PT7A7621-7625 and PT7A7631-7635 active-high RESET output is simply the inverse of the \overline{RESET} output, and is guaranteed to be valid with V_{CC} down to 1.2V. Some μ Ps, such as Intel's 80C51, require an active-high reset pulse.

Watchdog Timer

The watchdog circuit monitors the μ P activity. If the μ P does not toggle the watchdog input (WDI) within 1.6sec and WDI is not in high impedance, \overline{WDO} goes low. As long as \overline{RESET} is asserted or the WDI input is in high impedance, the watchdog timer will stay cleared and will not count. As soon as reset is released and WDI is driven high or low, the timer will start counting. Pulses as short as 50ns can be detected.

Typically, \overline{WDO} will be connected to the non-maskable interrupt input (NMI) of a μ P. When V_{CC} drops below the reset threshold, \overline{WDO} will go low whether or not the watchdog timer has timed out yet. Normally this would trigger an NMI interrupt, but \overline{RESET} goes low simultaneously, and thus overrides the NMI interrupt. If WDI is left unconnected, \overline{WDO} can be used as a low-line output. Since floating WDI disables the internal timer, \overline{WDO} goes low only when V_{CC} falls below the reset threshold, thus functioning as a low-line output.

Manual Reset

The manual-reset input (\overline{MR}) allows reset to be triggered by a push button switch. The switch is effectively debounced by the 140ms minimum reset pulse width. \overline{MR} is TTL/CMOS logic compatible, so it can be driven by any logic reset output.

Power-Fail Comparator

The power-fail comparator will send out a Low signal once detects a voltage lowered than 1.25V. It can be used for various purposes because its output and non-inverting input are not internally connected. The inverting input is internally connected to a 1.25V reference.

Performance Characteristics

NEW PRODUCT

Supply Current vs. Supply Voltage

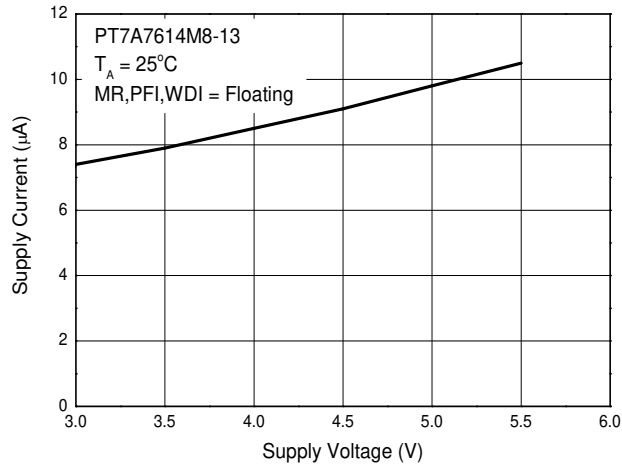

MR Pull-up Resistor vs. Temperature

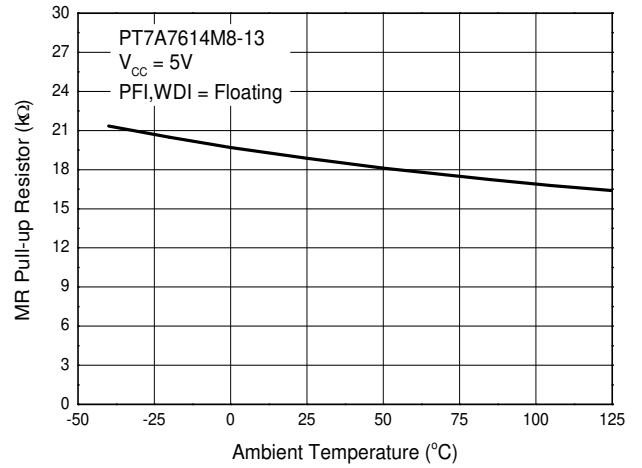

Reset Pulse Width vs. Temperature

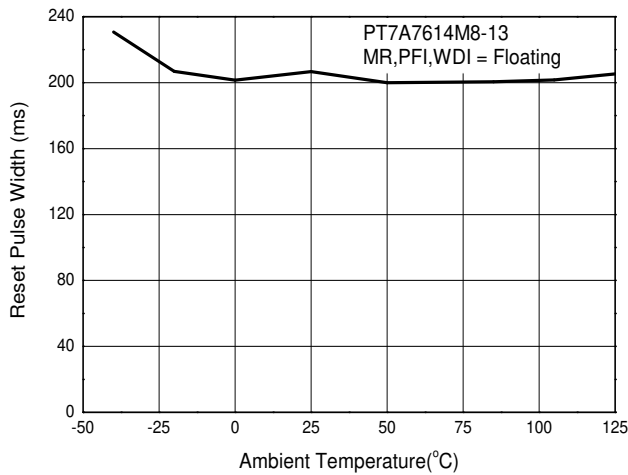

Ordering Information

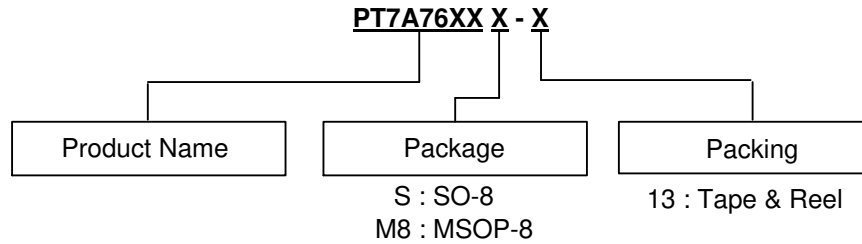

Part Number	Package Code	Packaging (Note 8)	13" Tape and Reel	
			Quantity	Part Number Suffix
PT7A761xS-13	S	SO-8	2500/Tape & Reel	-13
PT7A762xS-13	S	SO-8	2500/Tape & Reel	-13
PT7A763xS-13	S	SO-8	2500/Tape & Reel	-13
PT7A761xM8-13	M8	MSOP-8	2500/Tape & Reel	-13
PT7A762xM8-13	M8	MSOP-8	2500/Tape & Reel	-13
PT7A763xM8-13	M8	MSOP-8	2500/Tape & Reel	-13

Note: 8. Pad layout as shown in Diodes Incorporated's package outline PDFs, which can be found on our website at <http://www.diodes.com/package-outlines.html>.

Function Comparison Table

Part Number	Reset Threshold	Reset Active Low or High	Nom. Reset Time (ms), t_{rs}	Nom. Watchdog Time (sec), t_{wd}	Power Fail Comparator	Manual Reset Input
PT7A7611	4.63V	LOW	200	1.6	1.25V Detector	Yes
PT7A7621	4.63V	HIGH	200	1.6	1.25V Detector	Yes
PT7A7631	4.63V	LOW, HIGH	200	Unavailable	1.25V Detector	Yes
PT7A7612	4.38V	LOW	200	1.6	1.25V Detector	Yes
PT7A7622	4.38V	HIGH	200	1.6	1.25V Detector	Yes
PT7A7632	4.38V	LOW, HIGH	200	Unavailable	1.25V Detector	Yes
PT7A7613	3.08V	LOW	200	1.6	1.25V Detector	Yes
PT7A7623	3.08V	HIGH	200	1.6	1.25V Detector	Yes
PT7A7633	3.08V	LOW, HIGH	200	Unavailable	1.25V Detector	Yes
PT7A7614	2.93V	LOW	200	1.6	1.25V Detector	Yes
PT7A7624	2.93V	HIGH	200	1.6	1.25V Detector	Yes
PT7A7634	2.93V	LOW, HIGH	200	Unavailable	1.25V Detector	Yes
PT7A7615	2.63V	LOW	200	1.6	1.25V Detector	Yes
PT7A7625	2.63V	HIGH	200	1.6	1.25V Detector	Yes
PT7A7635	2.63V	LOW, HIGH	200	Unavailable	1.25V Detector	Yes

NEW PRODUCT

Marking Information

(1) SO-8

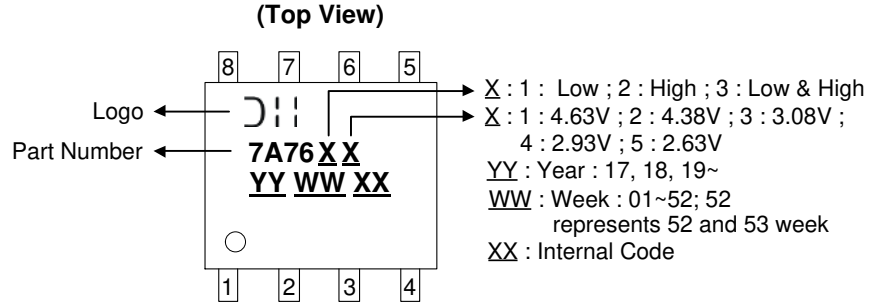

Part Number	Package	Identification Code
PT7A7611S-13	SO-8	7A7611
PT7A7612S-13	SO-8	7A7612
PT7A7613S-13	SO-8	7A7613
PT7A7614S-13	SO-8	7A7614
PT7A7615S-13	SO-8	7A7615
PT7A7621S-13	SO-8	7A7621
PT7A7622S-13	SO-8	7A7622
PT7A7623S-13	SO-8	7A7623
PT7A7624S-13	SO-8	7A7624
PT7A7625S-13	SO-8	7A7625
PT7A7631S-13	SO-8	7A7631
PT7A7632S-13	SO-8	7A7632
PT7A7633S-13	SO-8	7A7633
PT7A7634S-13	SO-8	7A7634
PT7A7635S-13	SO-8	7A7635

NEW PRODUCT

Marking Information (Cont.)

(2) MSOP-8

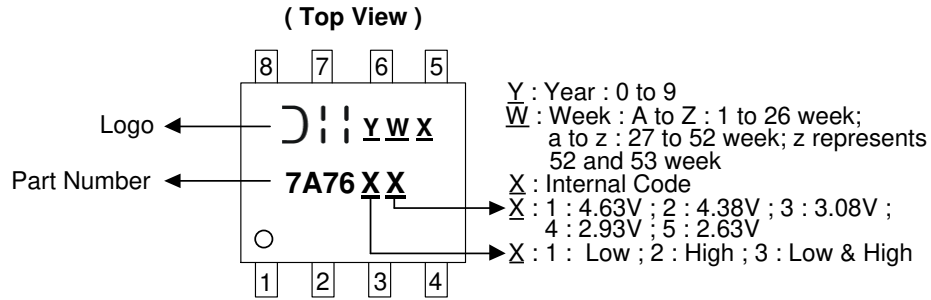

Part Number	Package	Identification Code
PT7A7611M8-13	MSOP-8	7A7611
PT7A7612M8-13	MSOP-8	7A7612
PT7A7613M8-13	MSOP-8	7A7613
PT7A7614M8-13	MSOP-8	7A7614
PT7A7615M8-13	MSOP-8	7A7615
PT7A7621M8-13	MSOP-8	7A7621
PT7A7622M8-13	MSOP-8	7A7622
PT7A7623M8-13	MSOP-8	7A7623
PT7A7624M8-13	MSOP-8	7A7624
PT7A7625M8-13	MSOP-8	7A7625
PT7A7631M8-13	MSOP-8	7A7631
PT7A7632M8-13	MSOP-8	7A7632
PT7A7633M8-13	MSOP-8	7A7633
PT7A7634M8-13	MSOP-8	7A7634
PT7A7635M8-13	MSOP-8	7A7635

NEW PRODUCT

Package Outline Dimensions

Please see <http://www.diodes.com/package-outlines.html> for the latest version.

(1) Package Type: SO-8

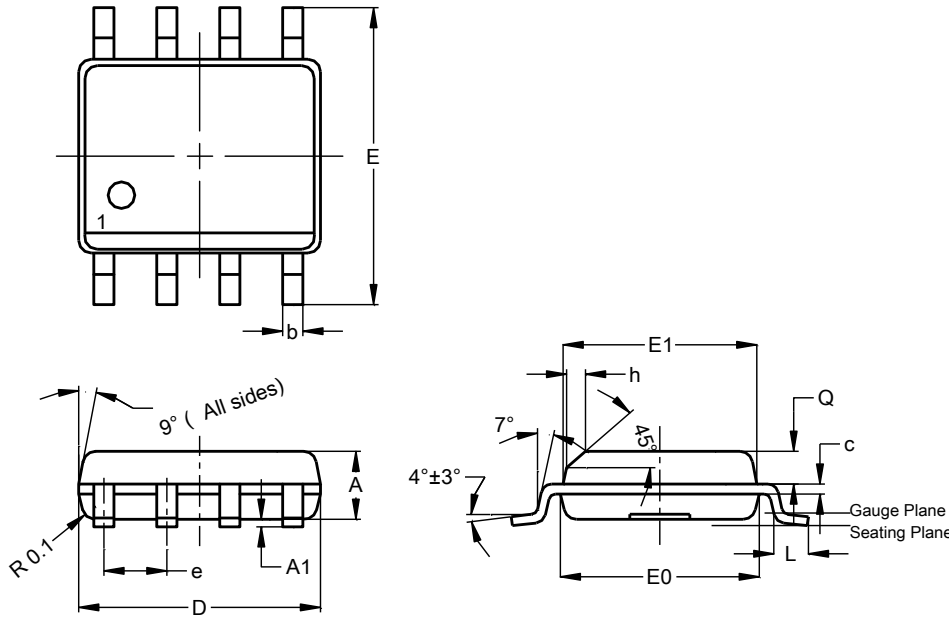

SO-8			
Dim	Min	Max	Typ
A	1.40	1.50	1.45
A1	0.10	0.20	0.15
b	0.30	0.50	0.40
c	0.15	0.25	0.20
D	4.85	4.95	4.90
E	5.90	6.10	6.00
E1	3.80	3.90	3.85
E0	3.85	3.95	3.90
e	--	--	1.27
h	--	--	0.35
L	0.62	0.82	0.72
Q	0.60	0.70	0.65

All Dimensions in mm

(2) Package Type: MSOP-8

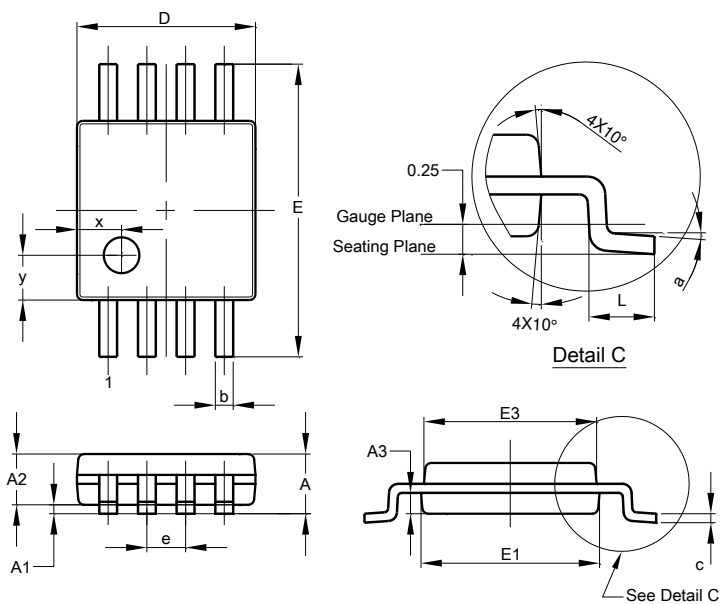

MSOP-8			
Dim	Min	Max	Typ
A	-	1.10	-
A1	0.05	0.15	0.10
A2	0.75	0.95	0.86
A3	0.29	0.49	0.39
b	0.22	0.38	0.30
c	0.08	0.23	0.15
D	2.90	3.10	3.00
E	4.70	5.10	4.90
E1	2.90	3.10	3.00
E3	2.85	3.05	2.95
e	-	-	0.65
L	0.40	0.80	0.60
a	0°	8°	4°
x	-	-	0.750
y	-	-	0.750

All Dimensions in mm

NEW PRODUCT

Suggested Pad Layout

Please see <http://www.diodes.com/package-outlines.html> for the latest version.

(1) Package Type: SO-8

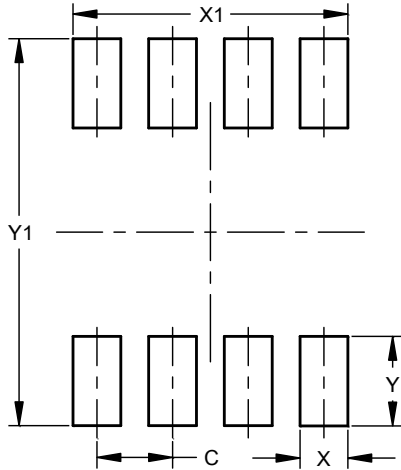

Dimensions	Value (in mm)
C	1.27
X	0.802
X1	4.612
Y	1.505
Y1	6.50

(2) Package Type: MSOP-8

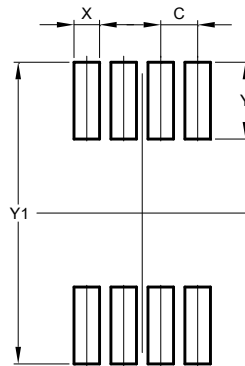

Dimensions	Value (in mm)
C	0.650
X	0.450
Y	1.350
Y1	5.300

IMPORTANT NOTICE

DIODES INCORPORATED MAKES NO WARRANTY OF ANY KIND, EXPRESS OR IMPLIED, WITH REGARDS TO THIS DOCUMENT, INCLUDING, BUT NOT LIMITED TO, THE IMPLIED WARRANTIES OF MERCHANTABILITY AND FITNESS FOR A PARTICULAR PURPOSE (AND THEIR EQUIVALENTS UNDER THE LAWS OF ANY JURISDICTION).

Diodes Incorporated and its subsidiaries reserve the right to make modifications, enhancements, improvements, corrections or other changes without further notice to this document and any product described herein. Diodes Incorporated does not assume any liability arising out of the application or use of this document or any product described herein; neither does Diodes Incorporated convey any license under its patent or trademark rights, nor the rights of others. Any Customer or user of this document or products described herein in such applications shall assume all risks of such use and will agree to hold Diodes Incorporated and all the companies whose products are represented on Diodes Incorporated website, harmless against all damages.

Diodes Incorporated does not warrant or accept any liability whatsoever in respect of any products purchased through unauthorized sales channel. Should Customers purchase or use Diodes Incorporated products for any unintended or unauthorized application, Customers shall indemnify and hold Diodes Incorporated and its representatives harmless against all claims, damages, expenses, and attorney fees arising out of, directly or indirectly, any claim of personal injury or death associated with such unintended or unauthorized application.

Products described herein may be covered by one or more United States, international or foreign patents pending. Product names and markings noted herein may also be covered by one or more United States, international or foreign trademarks.

This document is written in English but may be translated into multiple languages for reference. Only the English version of this document is the final and determinative format released by Diodes Incorporated.

LIFE SUPPORT

Diodes Incorporated products are specifically not authorized for use as critical components in life support devices or systems without the express written approval of the Chief Executive Officer of Diodes Incorporated. As used herein:

A. Life support devices or systems are devices or systems which:

1. are intended to implant into the body, or
2. support or sustain life and whose failure to perform when properly used in accordance with instructions for use provided in the labeling can be reasonably expected to result in significant injury to the user.

B. A critical component is any component in a life support device or system whose failure to perform can be reasonably expected to cause the failure of the life support device or to affect its safety or effectiveness.

Customers represent that they have all necessary expertise in the safety and regulatory ramifications of their life support devices or systems, and acknowledge and agree that they are solely responsible for all legal, regulatory and safety-related requirements concerning their products and any use of Diodes Incorporated products in such safety-critical, life support devices or systems, notwithstanding any devices- or systems-related information or support that may be provided by Diodes Incorporated. Further, Customers must fully indemnify Diodes Incorporated and its representatives against any damages arising out of the use of Diodes Incorporated products in such safety-critical, life support devices or systems.

Copyright © 2019, Diodes Incorporated

www.diodes.com