

THIS DRAWING IS UNPUBLISHED. RELEASED FOR PUBLICATION  
 © COPYRIGHT - By - ALL RIGHTS RESERVED.

LOC		DIST		REVISIONS			
P	LTR	DESCRIPTION		DATE	DWN	APVD	
AF	50	P					
		P		REVISED PER ECR-13-004343	30JUL13	KH KR	

- 1 FITS 0.81±0.025 X 4.75 [.032±.001 X .187] TAB
- 2 WIRE SIZE: 0.3-0.9mm<sup>2</sup> [22-18 AWG], STRANDED ONLY.  
STRIP LENGTH 7.14 [.281]
- 3 INSULATION SIZE: 4.19 [.165] MAX DIA.
- 4 CONTINUOUS STRIP

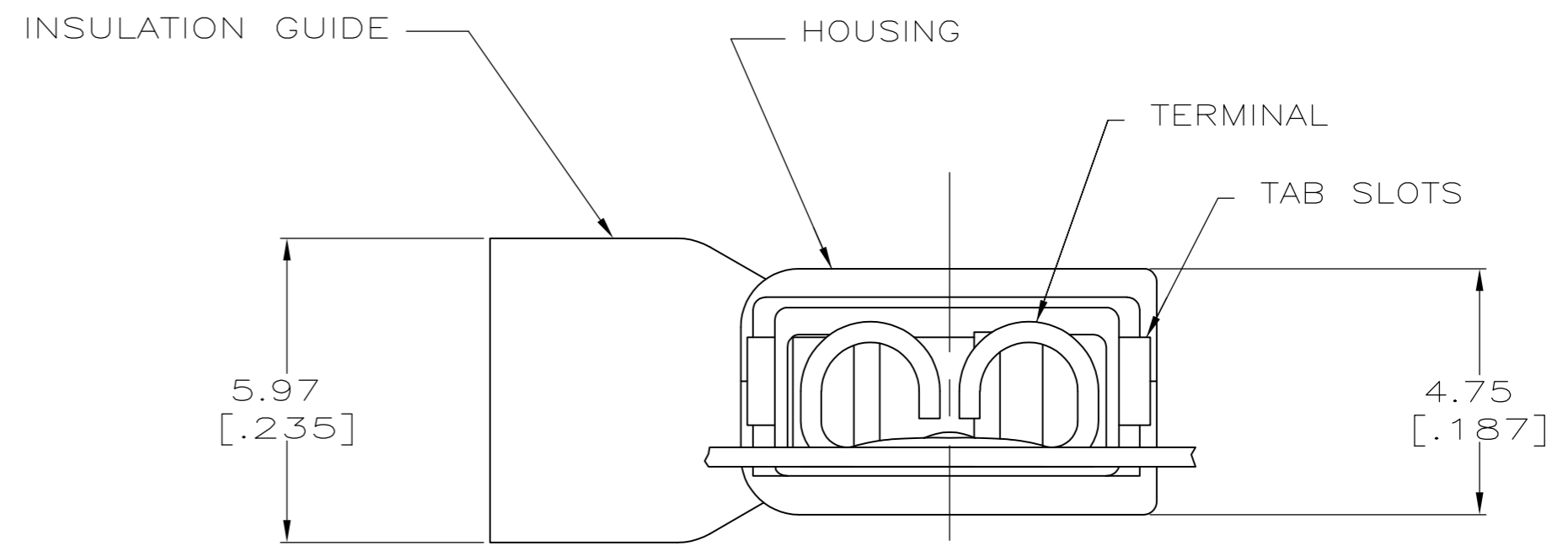
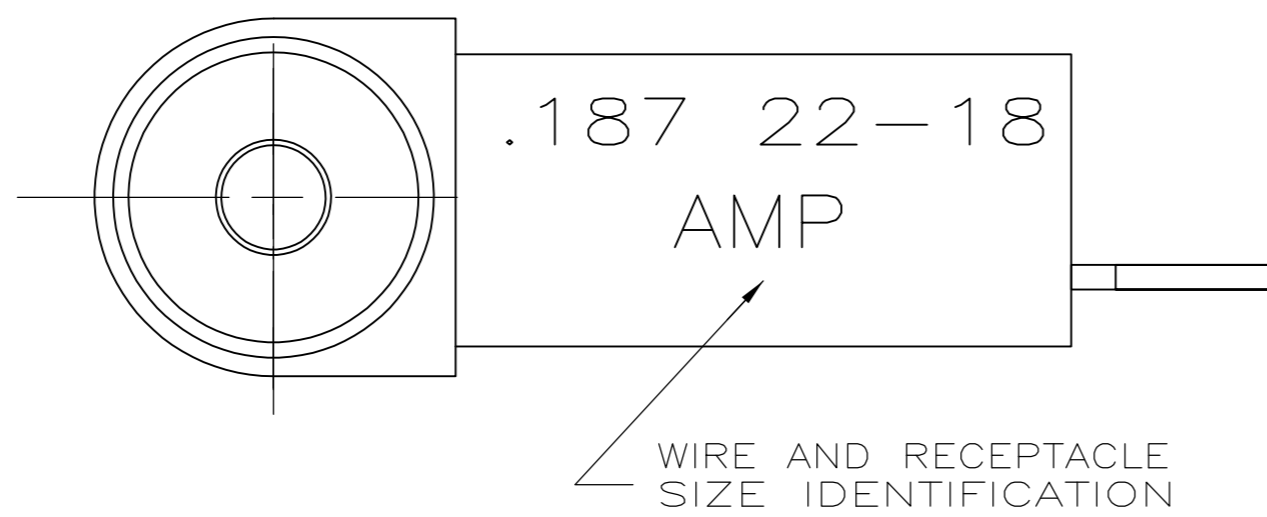
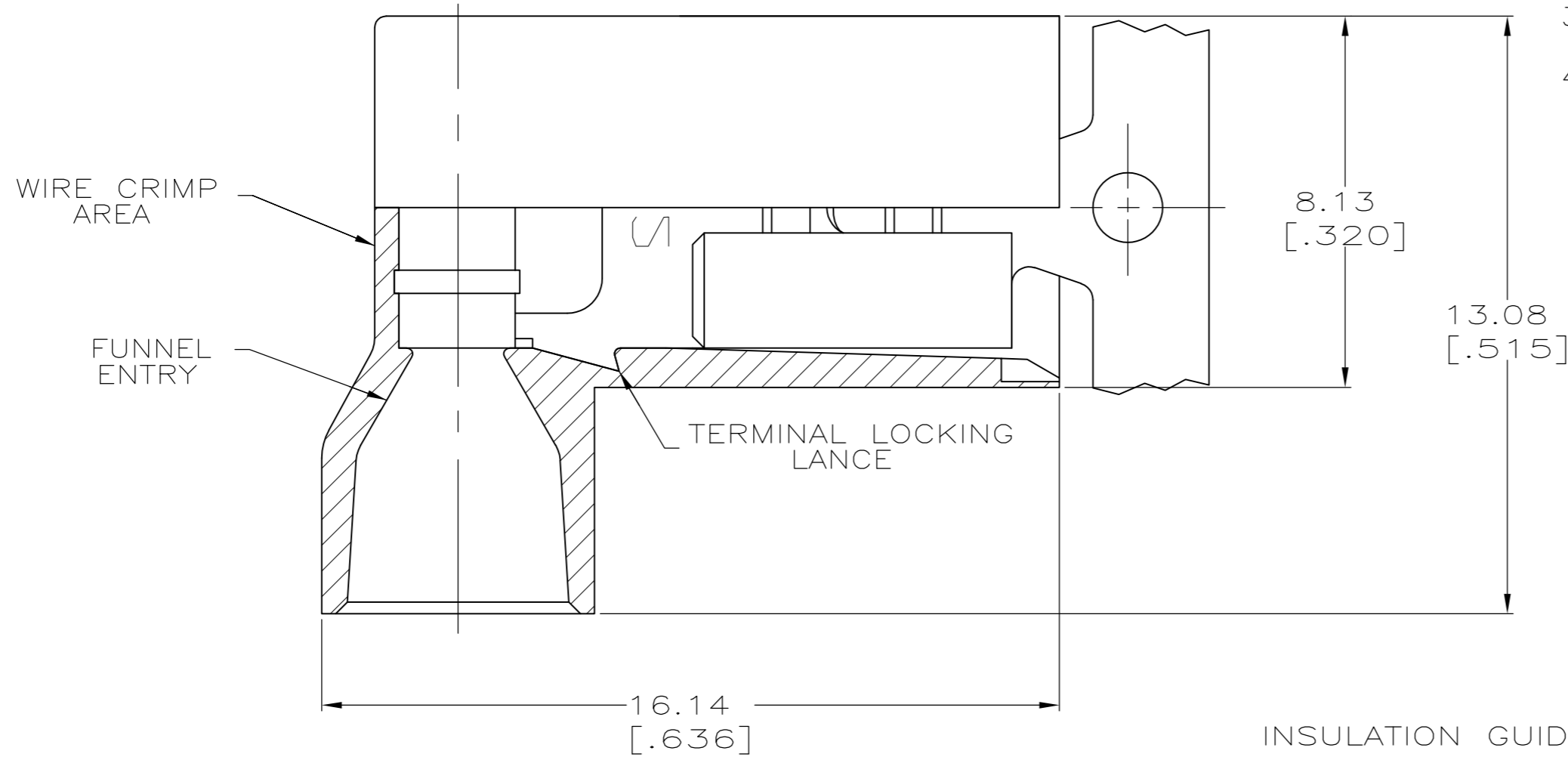

BULK		RED TRANSLUCENT			5-520336-2
STANDARD	TYPE 6/6 NYLON	BLACK	BRASS	TIN	9-520336-2
		RED TRANSLUCENT			2-520336-2
PACKAGING	MATERIAL	COLOR	MATERIAL	FINISH	PART NO
HOUSING			TERMINAL		

THIS DRAWING IS A CONTROLLED DOCUMENT.		DWN P FORTNEY 8/6/90	<b>TE</b> TE Connectivity		
		CHK MS FEHER 8/9/90			
DIMENSIONS: mm [INCHES]		APVD D BRATINA 8/17/90	NAME RECEPTACLE ASSEMBLY, ULTRA-FAST FLAG, 4.75 [.187] SERIES		
TOLERANCES UNLESS OTHERWISE SPECIFIED:		PRODUCT SPEC 108-2043	SIZE CAGE CODE DRAWING NO RESTRICTED TO		
0 PLC ± -		APPLICATION SPEC 114-2123	A2 00779 C=520336		
1 PLC ± -		WEIGHT -	SCALE 8:1 SHEET 1 of 1 REV P		
2 PLC ± 0.38 [.015]		CUSTOMER DRAWING			
3 PLC ± -					
4 PLC ± -					
ANGLES ± -					
FINISH SEE TABLE					