

LOC	DIST	REVISIONS					
E	B	P	LTR	DESCRIPTION	DATE	DWN	APVD
		A		EBD0-0122-04	25FEB04	JMS	FWK

NOTES:

- 1 SINGLE PACK IN ACCORDANCE WITH AMP SPEC 107-3275
- 2 100 TRAY PACK IN ACCORDANCE WITH AMP SPEC 107-3275
- 3 0.08µm Au PLATING OVER 1.27µm Ni PLATING OVER 0.76µm Cu PLATING
- 4 0.76µm Au PLATING OVER 1.27µm Ni PLATING OVER 0.76µm Cu PLATING
- 5 FOR TECHNICAL DATA REFER TO YOUR LOCAL TYCO ELECTRONICS SALES OFFICE
- 6 ALL DIMENSIONS ARE NOMINAL FOR REFERENCE ONLY UNLESS OTHERWISE STATED

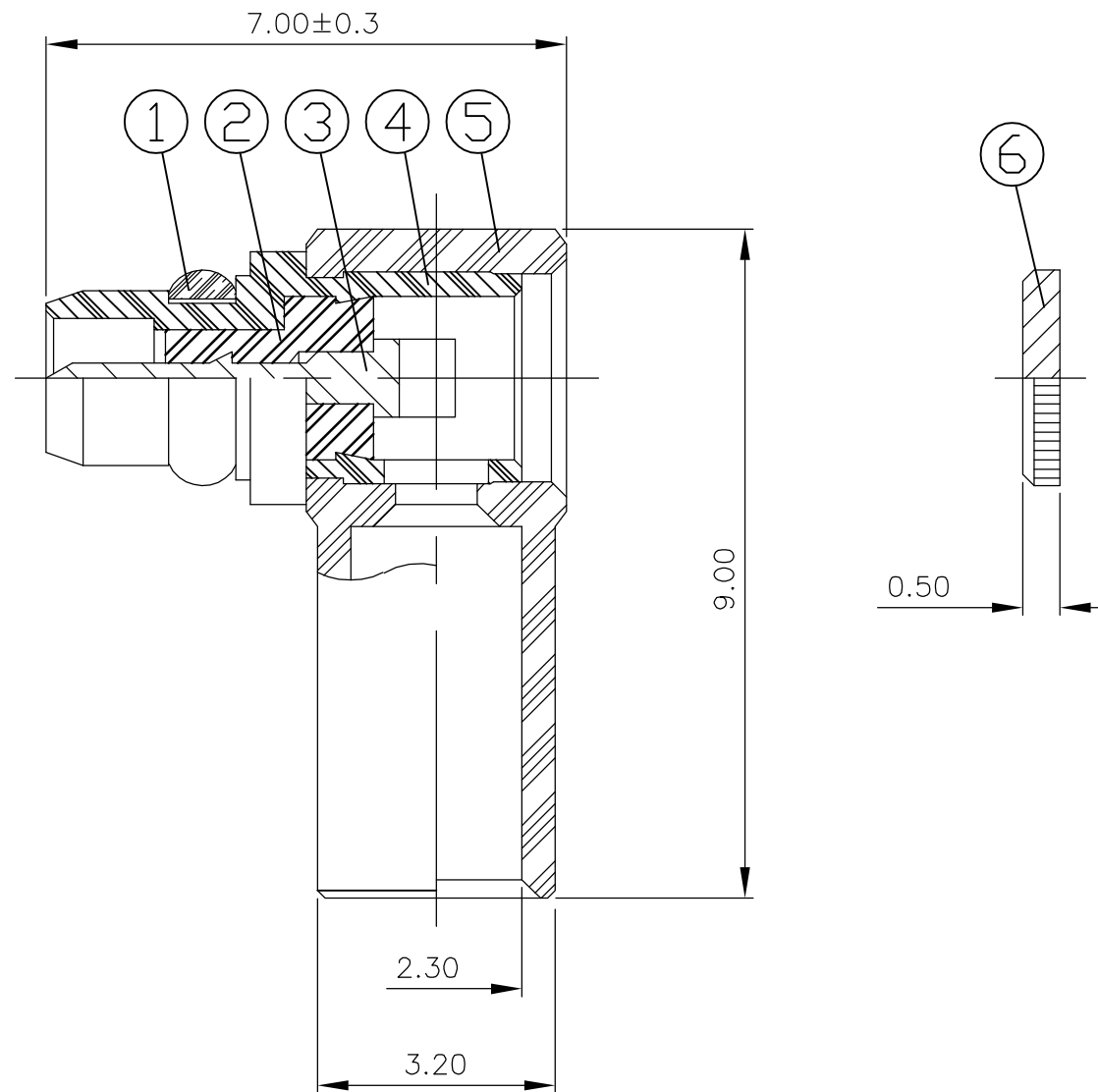

RECOMMENDED CABLE STRIPPING DIM'S

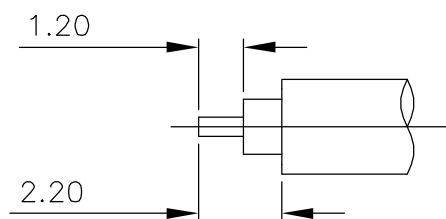

						1	1	BRASS	3	ACCESS CAP	6
						1	1	BRASS	3	BODY	5
						1	1	BRASS	3	BODY	4
						1	1	BRASS	4	PIN	3
						1	1	PTFE		INSULATOR	2
						1	1	BERYLLIUM COPPER	3	RETAINING RING	1
						1--1	1--0	MATERIAL		DESCRIPTION	ITEM
						2	1				
						QUANTITY PER ASSY			PARTS LIST		

THIS DRAWING IS A CONTROLLED DOCUMENT.		DWN J.SANDWELL 25FEB04	 Tyco Electronics Corporation Bideford, UK, EX39 4HE	
DIMENSIONS: MM		CHK S.PARLOW 25FEB04		
TOLERANCES UNLESS OTHERWISE SPECIFIED:		APVD F.WHEELER-KING 25FEB04	NAME GOLD PLATED MMCX ELBOW PLUG RG405 DIRECT SOLDER	
0 PLC ± -		PRODUCT SPEC 108-3462	SIZE A3	
1 PLC ± -		APPLICATION SPEC 411-3279	CAGE CODE 00779	DRAWING NO C-1634591
2 PLC ± -		WEIGHT -	RESTRICTED TO -	
3 PLC ± -		CUSTOMER DRAWING		
4 PLC ± -		SCALE NTS		
ANGLES ± 5		SHEET 1 OF 1		
FINISH -		REV A		
MATERIAL SEE TABLE				