

MINI MCR-SL-NAM-2RNO

NAMUR isolation amplifiers



Data sheet
102675_en_05

© PHOENIX CONTACT 2012-01-23

1 Description

The 6.2 mm wide MINI MCR-SL-NAM-2RNO... is a configurable 4-way isolation amplifier. It is suitable for the operation of proximity sensors according to EN 60947-5-6 as well as switches and is also equipped with two relay outputs. The second output can be used either for duplicating signals or for signaling faults on the sensor line.

The DIP switches are accessible on the side of the housing and allow the following parameters to be configured:

- Switchover from open circuit to closed circuit behavior
- Activation of line fault detection on the sensor cable as well as
- selecting signal duplication/fault signaling

The voltage (19.2 V DC to 30 V DC) can be supplied either via the connection terminal blocks of the module or in conjunction with the DIN rail connector.

Features

- Configurable 4-way isolation amplifier
- Inputs and outputs are configurable via DIP switches
- Approval for Ex-zone 2 (nA)
- Screw or spring-cage connection can be provided

**WARNING: Correct usage in potentially explosive areas**

The module is a category 3 item of electrical equipment. It is absolutely vital to follow the instructions provided here during installation and observe the information in the "Safety regulations and installation notes".



Make sure you always use the latest documentation.

It can be downloaded from the product at www.phoenixcontact.net/catalog.



This data sheet is valid for all products listed on the following page:

2	Table of contents	
1	Description	1
2	Table of contents	2
3	Ordering data	3
4	Technical data	3
5	Safety regulations and installation notes.....	5
	5.1 Installation notes	5
	5.2 Installation in the Ex area (zone 2).....	5
6	Installation	6
	6.1 Connection notes	6
	6.2 Structure	6
	6.3 Block diagram.....	6
	6.4 Power supply.....	6
	6.5 Assembly.....	7
	6.6 Connecting the wires	7
7	Configuration	8
	7.1 Configuration table.....	8
8	Mechanical contacts.....	9
	8.1 Line fault detection in the case of mechanical contacts.....	9
	8.2 Line fault detection in the case of mechanical contacts with resistance circuit	9
9	Diagnostics LED.....	9
10	Status table.....	10

3 Ordering data

Description	Type	Order No.	Pcs. / Pkt.
Configurable NAMUR switching amplifier for proximity sensors, floating switching contacts and switching contacts with resistance circuit. On the output side 2 N/O contact, with screw connection	MINI MCR-SL-NAM-2RNO	2864105	1
Configurable NAMUR switching amplifier for proximity sensors, floating switching contacts and switching contacts with resistance circuit. On the output side 2 N/O contact, with spring-cage connection	MINI MCR-SL-NAM-2RNO-SP	2810269	1
Accessories	Type	Order No.	Pcs. / Pkt.
DIN rail connector (TBUS), 5-pos., for bridging the supply voltage, can be snapped onto NS 35/... DIN rails according to EN 60715	ME 6,2 TBUS-2 1,5/5-ST-3,81 GN	2869728	10
MCR power terminal block for supplying several MINI Analog modules via the DIN rail connectors, with screw connection, current consumption up to max. 2 A	MINI MCR-SL-PTB	2864134	1
MCR power terminal block for supplying several MINI-ANALOG modules via the DIN rail connectors, with spring-cage connection, current consumption up to max. 2 A	MINI MCR-SL-PTB-SP	2864147	1
DIN rail power supply unit, primary-switched mode, slim design, output: 24 V DC / 1.5 A	MINI-SYS-PS-100-240AC/24DC/1.5	2866983	1
DIN rail power supply unit, primary-switched mode, slim design, output: 24 V DC / 1.5 A, ATEX approval	MINI-PS-100-240AC/24DC/1.5/EX	2866653	1
Eight MINI analog signal converters with screw connection method can be connected to a control system using a system adapter and system cabling with a minimum of wiring and very low error risk.	MINI MCR-SL-V8-FLK 16-A	2811268	1
Fold up transparent cover for MINI MCR modules with additional labeling option using insert strips and flat Zack marker strip 6.2 mm	MINI MCR DKL	2308111	10
Label for extended marking of MINI MCR modules in connection with the MINI MCR-DKL	MINI MCR-DKL-LABEL	2810272	10

4 Technical data

Input	
Description of the input	Signal input
Available input sources	NAMUR proximity sensors (EN 60947-5-6) open circuit switch contacts Switch contacts with resistance circuit
Line monitoring	Activated/deactivated via DIP switches
Input name	Control current circuit
Non-load voltage	8.2 V DC $\pm 10\%$
Switching threshold "0" signal current	< 1.2 mA (blocking)
Switching threshold "1" signal, current	> 2.1 mA (conductive)
Line error detection	> 6 mA (in the event of a short-circuit) < 0.35 mA (With wire break)

Output	
Output description	Relay output
Output description	Output 1: Signal output; Output 2: Fault signaling output or signal duplicator, can be set via DIP switches
Contact type	2 N/O contacts
Contact material	Hard gold plated AgNi
Switching behavior	can be inverted using DIP switch
Behavior with line fault detection (LF) activated	Output 1 at zero current, output 2 closes
Maximum switching voltage	250 V AC 125 V DC
Maximum inrush current	2 A
Min. switching current	1 mA (for 5 V DC)
Typical response time	15 ms
Typical turn-off time	20 ms
Switching frequency	0.5 Hz (240 V AC / 30 V DC / 2 A) 10 Hz (without load)

Supply	
Supply voltage	Supply
Nominal supply voltage	24 V DC
Supply voltage range	19.2 V DC ... 30 V DC (to bridge the supply voltage, the DIN rail connector (ME 6,2 TBUS-2 1,5/5-ST-3,81 GN, Order No. 2869728) can be used. It can be snapped onto a 35 mm DIN rail according to EN 60715)
Max. current consumption	< 25 mA
Power consumption	< 600 mW

Diagnostic and status indicators	
Status display	Red LED (error messages) Yellow LED (relay status messages)

General data	
Electrical isolation	Basic insulation according to EN 61010
Surge voltage category	II
Mounting position	Any
Degree of protection	IP20
Pollution degree	2
Rated insulation voltage	250 V AC (Input/relay outputs) 250 V AC (Supply/relay outputs) 250 V AC (Relay output 1/relay output 2)
Test voltage, input/output/supply	1.5 kV (50 Hz, 1 min.)
Dimensions W / H / D	6.2 mm / 93.1 mm / 102.5 mm
Type of housing	PBT green

Connection data	Screw connection	Spring-cage conn.
Conductor cross section, solid	0.2 mm ² ... 2.5 mm ²	0.2 mm ² ... 2.5 mm ²
Conductor cross section, stranded	0.2 mm ² ... 2.5 mm ²	0.2 mm ² ... 2.5 mm ²
Stripping length	12 mm	8 mm

Ambient conditions	
Ambient temperature (operation)	-20 °C ... 65 °C
Ambient temperature (storage/transport)	-40 °C ... 85 °C

Conformance with EMC Directive 2004/108/EC

Noise immunity according to EN 61000-6-2

Noise emission according to EN 61000-6-4

Conformance / approvals

Conformance	CE-compliant
ATEX	Ⓔ II 3 G Ex nA nC IIC T4 Gc X
UL, USA / Canada	UL 508 Recognized
UL, USA / Canada	Class I, Div. 2, Groups A, B, C, D T5 applied for
Shipbuilding	GL EMC 2 D

5 Safety regulations and installation notes

5.1 Installation notes

- The category 3 device is suitable for installation in the zone 2 potentially explosive area. It fulfills the requirements of EN 60079-0:2009 and EN 60079-15:2010.
- Installation, operation, and maintenance may only be carried out by qualified electricians. Follow the installation instructions described. When installing and operating the device, the applicable regulations and safety directives (including national safety directives), as well as general technical regulations, must be observed. The technical data is provided in this package slip and on the certificates (conformity assessment, additional approvals where applicable).
- It is not permissible to open or modify the device. Do not repair the device yourself but replace it with an equivalent device. Repairs may only be carried out by the manufacturer. The manufacturer is not liable for damage resulting from violation.
- The IP20 degree of protection (IEC 60529/EN 60529) of the device is intended for use in a clean and dry environment. Do not subject the device to any load that exceeds the described limits.
- The device is not designed for use in atmospheres with a danger of dust explosions.

5.2 Installation in the Ex area (zone 2)

- Observe the specified conditions for use in potentially explosive areas.
- The device must be installed in a housing (control or distributor box) which meets the requirements of EN 60079-15 and provides at least IP54 (EN 60529) degree of protection.
- During installation and when connecting the supply and signal circuits, observe the requirements of EN 60079-14. Devices may only be connected to circuits in zone 2 if they are suitable for operation in Ex zone 2 and for the prevailing conditions at the place of use.
- In potentially explosive areas, terminals may only be snapped onto or off the DIN rail connector and wires may only be connected or disconnected when the power is switched off.
- The device must be stopped and immediately removed from the Ex area if it is damaged, has been subjected to an impermissible load, has been stored incorrectly, or if it malfunctions.
- You can download the latest documents for these devices from www.phoenixcontact.net/catalog.

6 Installation

6.1 Connection notes



NOTE: Electrostatic discharge!

The device contains components that can be damaged or destroyed by electrostatic discharge. When handling the device, observe the necessary safety precautions against electrostatic discharge (ESD) according to EN 61340-5-1 and EN 61340-5-2.

6.2 Structure

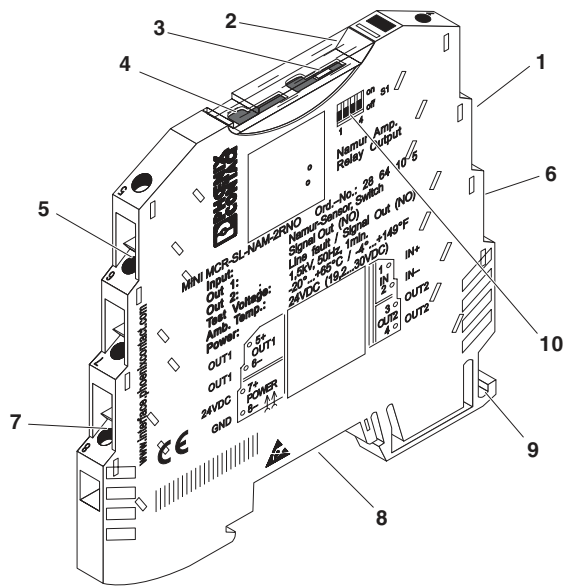

Figure 1 Structure

1. Input
2. Cover
3. Diagnostics LED
4. Groove for ZBF 6 zack marker strip
5. Output 1 relay contact
6. Output 2 relay contact
7. Supply voltage
8. Connection option for DIN rail connector
9. Universal snap-on foot for EN DIN rails
10. DIP switch S1

6.3 Block diagram

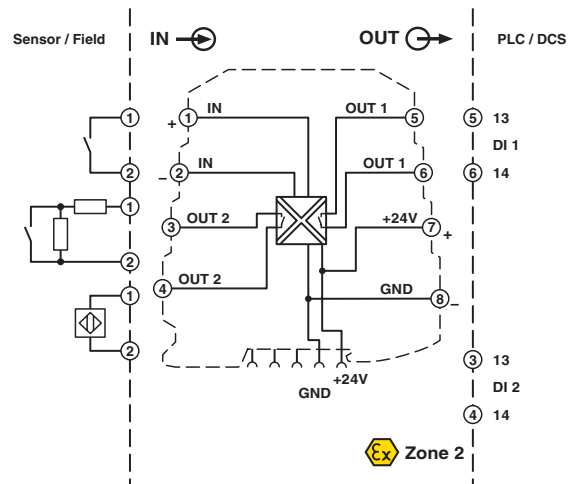

Figure 2 Block diagram

6.4 Power supply



NOTE: Never connect the supply voltage directly to the DIN rail connector. It is not permitted to draw power from the DIN rail connector or from individual modules.

Supply via the module

Where the total current consumption of the aligned modules does not exceed 400 mA, the power can be supplied directly at the connection terminal blocks of the module.

A 400 mA fuse should be connected upstream.

Supply via a power terminal block

The MINI MCR-SL-PTB power terminal block (Order No. 2864134) or the MINI MCR-SL-PTB-SP power terminal block (Order No. 2864147), which are the same shape, are used to feed the supply voltage to the DIN rail connector.

A 2 A fuse should be connected upstream.

Supply via a system power supply unit

The system power supply unit with 1.5 A output current connects the DIN rail connector to the supply voltage and can thus be used to supply several modules from the mains.

- MINI-SYS-PS-100-240AC/24DC/1.5 (Order No. 2866983)
- Potentially explosive areas:
MINI-PS-100-240AC/24DC/1.5/EX (Order No. 2866653)

6.5 Assembly

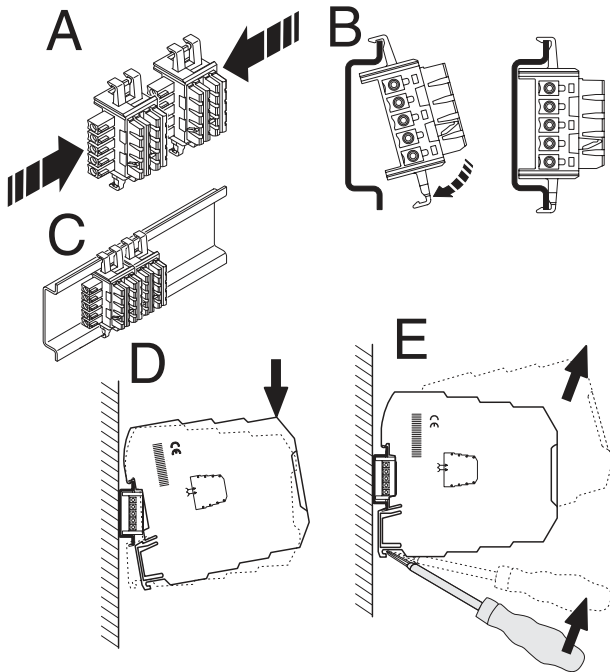

Figure 3 Mounting and removing

- Mount the module on a 35 mm DIN rail according to EN 60715.
- When using the DIN rail connector, first place it into the DIN rail (see A – C). It is used to bridge the power supply. It is also absolutely vital that you snap the module and the DIN rail connector into position in the correct direction: the snap-on foot should be at the bottom and the connector on the left.

6.6 Connecting the wires

The MINI MCR-SL-NAM-2RNO... is available in two connection variants:

- Screw terminal blocks (MINI MCR-SL-NAM-2RNO)
- Spring-cage terminal blocks (MINI MCR-SL-NAM-2RNO-SP)

Screw connection:

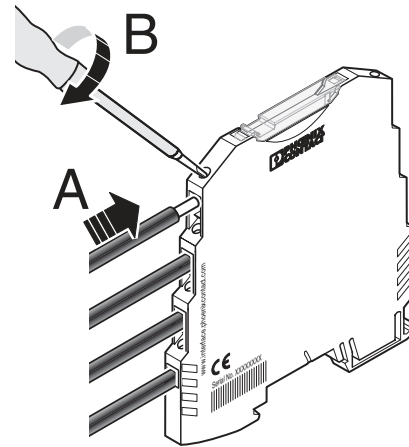

Figure 4 Screw connection

- Insert the wire into the corresponding connection terminal block.
- Use a screwdriver to tighten the screw in the opening above the connection terminal block.

Spring-cage connection:

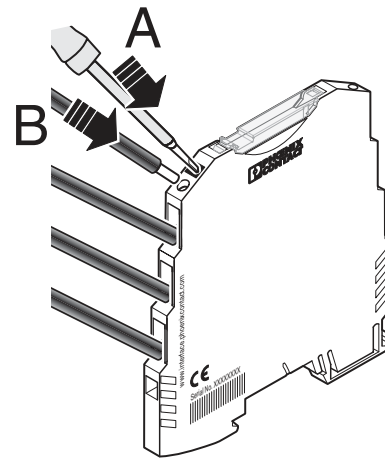

Figure 5 Spring-cage connection

- Insert a screwdriver into the opening above the connection terminal block.
- Insert the wire into the corresponding connection terminal block.

7 Configuration

Normal functions are set in the standard configuration (all DIP switches at pos. 0), cable monitoring and output 2 switched off.

Inversion (switchover of open circuit to closed circuit behavior), sensor cable monitoring and signal duplication/fault signaling is set with DIP switch 1.

If a line fault occurs, the signal relay (output 1) drops out and the red "LF" LED lights up (see below).

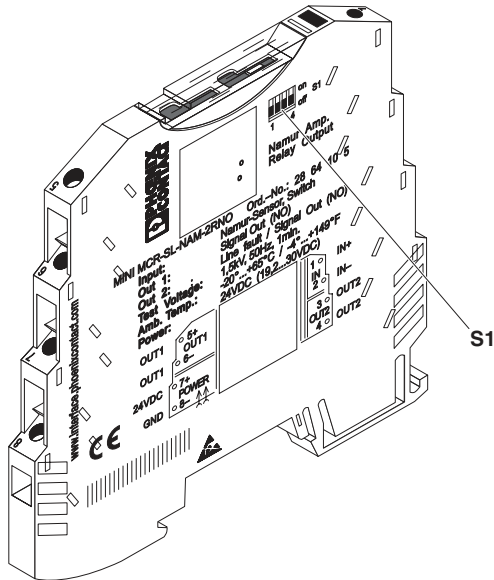

Figure 6 Location of the DIP switches

7.1 Configuration table

DIP switches

DIP S1		Operating current/closed circuit current behavior switch-over		Line fault detection (LF)		Output 2	
1			Normal (N)	2		3	4
	•		Inverted (I)		•		•
					•		•
					•		•
							•
							•

- ≙ ON
- ≙ OFF

8 Mechanical contacts

8.1 Line fault detection in the case of mechanical contacts



In the case of mechanical contacts, line fault detection (LF) must be switched off at DIP S1/2!

For short distances (< 10 m). The RL1 and RL2 cable resistance are incorporated directly into the measurement result.

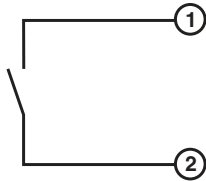

Figure 7 Connection example

8.2 Line fault detection in the case of mechanical contacts with resistance circuit



In the case of mechanical contacts with resistance circuit, the corresponding resistance circuit must be dealt with directly at the mechanical contacts (e. g., UKK 5-2R/NAMUR (Order No. 2941662) with D-UKK 3/5 (Order No. 2770024))!

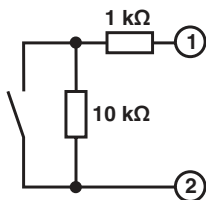

Figure 8 Connection example

9 Diagnostics LED

If line fault detection is activated and the correct input circuit has been observed, the red LED indicates the "line fault" status. The yellow LED indicates the state of the relay outputs (see "Status table").

10 Status table

Sensor in input		Input circuit	DIP S1				Output 1/ Output 2 (signal duplicator)	Output 2 (error indicator)	ST LED	LF LED
			1		2					
Switch	NAMUR		N	I	NLF	LF	Relay	Relay	Yellow	Red
Open	Attenuated	-	X		X		Open	Open		
Closed	Non-attenuated	-	X		X		Closed	Open	X	
Open	Attenuated	-		X	X		Closed	Open	X	
Closed	Non-attenuated	-		X	X		Open	Open		
	Any	Open circuit	X			X	Open	Closed		X
	Attenuated	OK	X			X	Open	Open		
	Non-attenuated	OK	X			X	Closed	Open	X	
	Any	Short circuit	X			X	Open	Closed		X
	Any	Open circuit		X		X	Open	Closed		X
	Attenuated	OK		X		X	Closed	Open	X	
	Non-attenuated	OK		X		X	Open	Open		
	Any	Short circuit		X		X	Open	Closed		X