

Half-Bridge N-Channel MOSFET Driver for DC/DC Conversion

DESCRIPTION

The SiP41104 is a high-speed half-bridge MOSFET driver for use in high frequency, high current, multiphase dc-to-dc synchronous rectifier buck power supplies. It is designed to operate at switching frequencies up to 1 MHz. The high-side driver is bootstrapped to allow driving N-channel MOSFETs.

The SiP41104 comes with adaptive shoot-through protection to prevent simultaneous conduction of the external MOSFETs.

The SiP41104 is available in both standard and lead (Pb)-free 8 pin SOIC packages and is specified to operate over the industrial temperature range of - 40 °C to 85 °C.

FEATURES

- 5 V gate drive
- Undervoltage lockout
- Internal bootstrap diode
- PWM pin tristate enable feature
- Switching frequency up to 1 MHz
- Drive MOSFETs in 4.5 V to 50 V systems
- Compliant to RoHS directive 2002/95/EC



RoHS*
COMPLIANT

APPLICATIONS

- Multi-phase DC/DC conversion
- High current synchronous buck converters
- High frequency synchronous buck converters
- Asynchronous-to-synchronous adaptations
- Mobile computer DC/DC converters
- Desktop computer DC/DC converters

FUNCTIONAL BLOCK DIAGRAM

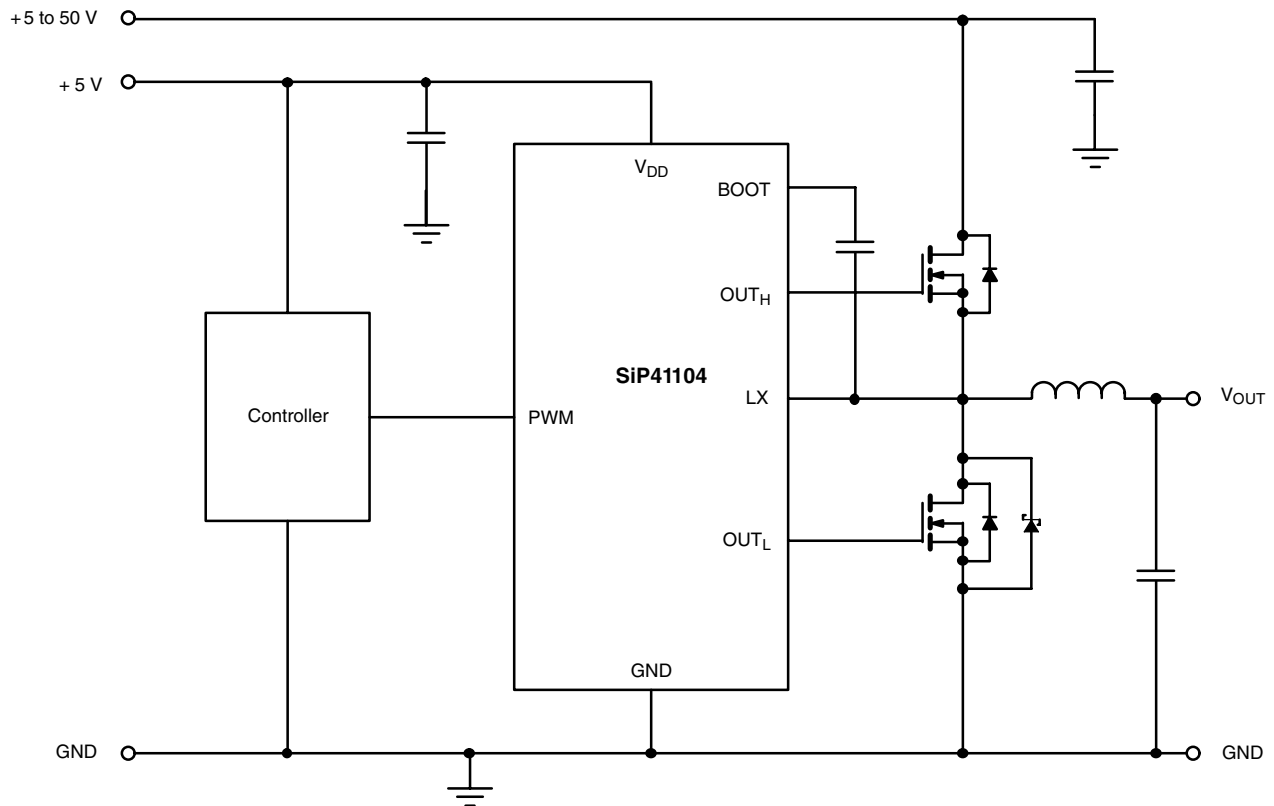

*Pb containing terminations are not RoHS compliant, exemptions may apply.

ABSOLUTE MAXIMUM RATINGS (all voltages referenced to GND = 0 V)			
Parameter		Limit	Unit
V _{DD} , PWM		7	V
LX, BOOT		55	
BOOT to LX		7	
Storage Temperature		- 40 to 150	°C
Operating Junction Temperature		125	
Power Dissipation ^a	SO-8	770	mW
Thermal Impedance (Θ_{JA}) ^a		130	°C/W

Notes:

a. Device mounted with all leads soldered or welded to PC board.

a. Derate 7.7 mW/°C.

Stresses beyond those listed under "Absolute Maximum Ratings" may cause permanent damage to the device. These are stress ratings only, and functional operation of the device at these or any other conditions beyond those indicated in the operational sections of the specifications is not implied. Exposure to absolute maximum rating conditions for extended periods may affect device reliability.

RECOMMENDED OPERATING RANGE (all voltages referenced to GND = 0 V)			
Parameter		Limit	Unit
V _{DD}		4.5 to 5.5	V
V _{BOOT}		4.5 to 50	
C _{BOOT}		100 nF to 1 μ F	
Operating Temperature Range		- 40 to 85	°C

SPECIFICATIONS^a						
Parameter	Symbol	Test Conditions Unless Specified V _{DD} = 5 V, V _{BOOT} - V _{LX} = 5 V, C _{LOAD} = 3 nF T _A = - 40 °C to 85 °C	Limits			Unit
			Min. ^a	Typ. ^b	Max. ^a	
Power Supplies						
Supply Voltage	V _{DD}		4.5		5.5	V
Quiescent Current	I _{DDQ}	f _{PWM} = 1 MHz, C _{LOAD} = 0		2.5	3.5	mA
Tristate Current	I _{DDT}	PWM = open		500	1000	μ A
Reference Voltage						
Break-Before-Make	V _{BBM}			1		V
PWM Input						
Input High	V _{IH}		4.0		V _{DD}	V
Input Low	V _{IL}				0.5	
Bias Current	I _B	T _A = 25 °C		\pm 700	\pm 1400	μ A
Tristate Threshold	High	V _{TSH}	3.2			V
	Low	V _{TSL}			1.9	
Tristate Shutdown Timeout ^c	t _{TST}	Rising or falling		425		ns
High-Side Undervoltage Lockout						
Threshold	V _{UVHS}	Rising or falling	2.5	3.35	3.75	V
Bootstrap Diode						
Forward Voltage	V _F	I _F = 10 mA, T _A = 25 °C	0.70	0.76	0.82	V



SPECIFICATIONS^a						
Parameter	Symbol	Test Conditions Unless Specified $V_{DD} = 5\text{ V}$, $V_{BOOT} - V_{LX} = 5\text{ V}$, $C_{LOAD} = 3\text{ nF}$ $T_A = -40\text{ }^\circ\text{C to }85\text{ }^\circ\text{C}$	Limits			Unit
			Min. ^a	Typ. ^b	Max. ^a	
MOSFET Drivers						
High-Side Drive Current ^c	$I_{PKH(source)}$	$V_{BOOT} - V_{SH} = 4.5\text{ V}$		0.9		A
	$I_{PKH(sink)}$			1.1		
Low-Side Drive Current ^c	$I_{PKL(source)}$	$V_{DD} = 4.5\text{ V}$		0.8		
	$I_{PKL(sink)}$			1.5		
High-Side Driver Impedance	$R_{DH(source)}$	$V_{DD} = 4.5\text{ V}$, $S_H = GND$		2.5	3.8	Ω
	$R_{DH(sink)}$			2.2	3.3	
Low-Side Driver Impedance	$R_{DL(source)}$	$V_{DD} = 4.5\text{ V}$		3.4	5.1	
	$R_{DL(sink)}$			1.4	2.1	
High-Side Rise Time	t_{rH}	10 % - 90 %		32	40	ns
High-Side Fall Time	t_{fH}	90 % - 10 %		36	45	
High-Side Propagation Delay ^c	$t_{d(off)H}$	See Timing Waveforms		20		
	$t_{d(on)H}$	See Timing Waveforms		30		
Low-Side Rise Time	t_{rL}	10 % - 90 %		45	55	
Low-Side Fall Time	t_{fL}	90 % - 10 %		20	30	
Low-Side Propagation Delay ^c	$t_{d(off)L}$	See Timing Waveforms		30		
	$t_{d(on)L}$	See Timing Waveforms		30		
LX Timer						
LX Falling Timeout ^c	t_{LX}			420		ns
V_{DD} Undervoltage Lockout						
Threshold Rising	V_{UVLOR}			4.3	4.5	V
Threshold Falling	V_{UVLOF}		3.7	4.1		
Hysteresis				0.4		
Power on Reset Time				2.5		ms
Thermal Shutdown						
Temperature	T_{SD}	Temperature rising		165		$^\circ\text{C}$
Hysteresis	T_H	Temperature falling		25		

Notes:

- a. The algebraic convention whereby the most negative value is a minimum and the most positive a maximum (-40 °C to 85 °C).
- b. Typical values are for DESIGN AID ONLY, not guaranteed nor subject to production testing and are measured at $V_{CC} = 5\text{ V}$ unless otherwise noted.
- c. Guaranteed by design.

TIMING WAVEFORMS

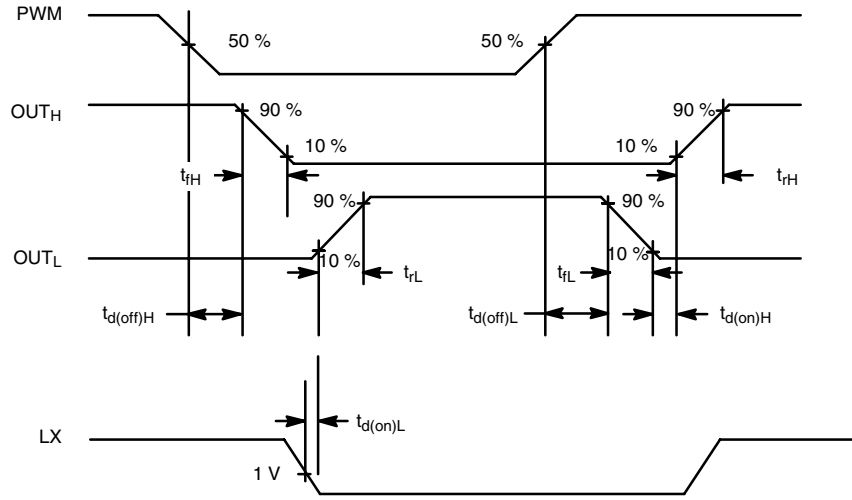

PIN CONFIGURATION AND TRUTH TABLE

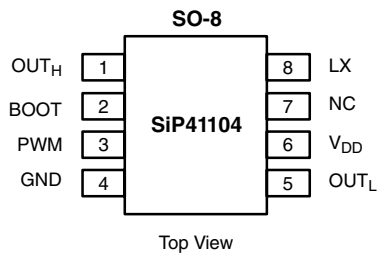

TRUTH TABLE

PWM	OUT _H	OUT _L
L	L	H
L	H	L
TriState	L	L

ORDERING INFORMATION

Part Number	Temperature Range	Marking
SiP41104DY-T1	- 40 °C to 85 °C	41104
SiP41104DY-T1-E3		
Eval Kit	Temperature Range	
SiP41104DB	- 40 °C to 85 °C	

PIN DESCRIPTION

Pin Number	Name	Function
1	OUT _H	High-side MOSFET gate drive
2	BOOT	Bootstrap supply for high-side driver. A capacitor connects between BOOT and LX.
3	PWM	Input signal for the MOSFET drivers
4	GND	Ground
5	OUT _L	Synchronous or low-side MOSFET gate drive
6	V _{DD}	+ 5 V supply
7	NC	No connect
8	LX	Connection to source of high-side MOSFET, drain of the low-side MOSFET, and the inductor

FUNCTIONAL BLOCK DIAGRAM

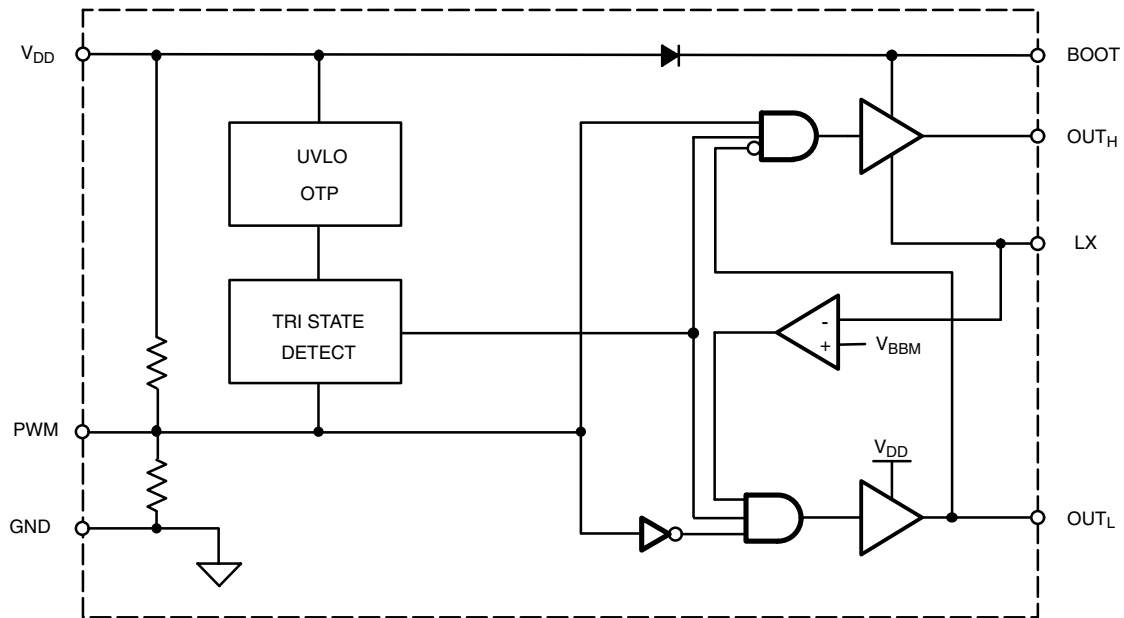

Figure 1.

DETAILED OPERATION

PWM

The PWM pin controls the switching of the external MOSFETs. The driver logic operates in a noninverting configuration. The PWM input stage should be driven by a signal with fast transition times, like those provided by a PWM controller or logic gate, (< 200 ns). The PWM input functions as a logic input and is not intended for applications where a slow changing input voltage is used to generate a switching output when the input switching threshold voltage is reached.

Low-Side Driver

The supplies for the low-side driver are V_{DD} and GND. During shutdown, OUT_L is held low.

High-Side Driver

The high-side driver is isolated from the substrate to create a floating high-side driver so that an N-Channel MOSFET can be used for the high-side switch. The supplies for the high-side driver are BOOT and LX. The voltage is supplied by a floating bootstrap capacitor, which is continually recharged by the switching action of the output. During shutdown OUT_H is held low.

Bootstrap Circuit

The internal bootstrap diode and a bootstrap capacitor form a charge pump that supplies voltage to the BOOT pin. An integrated bootstrap diode replaces the external Schottky

diode needed for the bootstrap circuit; only a capacitor is necessary to complete the bootstrap circuit. The bootstrap capacitor is sized according to,

$$C_{BOOT} = (Q_{GATE} / \Delta V_{BOOT - LX}) \times 10$$

where Q_{GATE} is the gate charge needed to turn on the high-side MOSFET and $\Delta V_{BOOT - LX}$ is the amount of droop allowed in the bootstrapped supply voltage when the high-side MOSFET is driven high. The bootstrap capacitor value is typically 0.1 μF to 1 μF . The bootstrap capacitor voltage rating must be greater than $V_{DD} + 5 V$ to withstand transient spikes and ringing.

Shoot-Through Protection

The external MOSFETs are prevented from conducting at the same time during transitions. Break-before-make circuits monitor the voltages on the LX pin and the OUT_L pin and control the switching as follows: When the signal on PWM goes low, OUT_H will go low after an internal propagation delay. After the voltage on LX falls below 1 V by the inductor action, the low-side driver is enabled and OUT_L goes high after some delay. When the signal on PWM goes high, OUT_L will go low after an internal propagation delay. After the voltage on OUT_L drops below 1 V the high-side driver is enabled and OUT_H will go high after an internal propagation delay. If LX does not drop below 1 V within 400 ns after OUT_H goes low, OUT_L is forced high until the next PWM transition.

Shutdown

The driver enters shutdown mode when the signal driving PWM enters HiZ or “tristate” mode for more than 400 ns.

V_{DD} Bypass Capacitor

MOSFET drivers draw large peak currents from the supplies when they switch. A local bypass capacitor is required to supply this current and reduce power supply noise. Connect a 1 μ F ceramic capacitor as close as practical between the V_{DD} and GND pins.

Undervoltage Lockout

Undervoltage lockout prevents control of the circuit until the supply voltages reach valid operating levels. The UVLO circuit forces OUT_L and OUT_H to low when V_{DD} is below its specified voltage. A separate UVLO forces OUTH low when the voltage between BOOT and LX is below the specified voltage.

Thermal Protection

If the die temperature rises above 165 °C, the thermal protection disables the drivers. The drivers are re-enabled after the die temperature has decreased below 140 °C.

TYPICAL CHARACTERISTICS

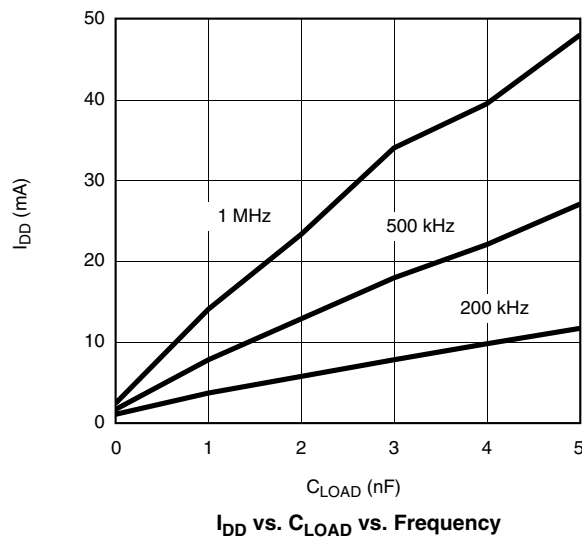

TYPICAL WAVEFORMS

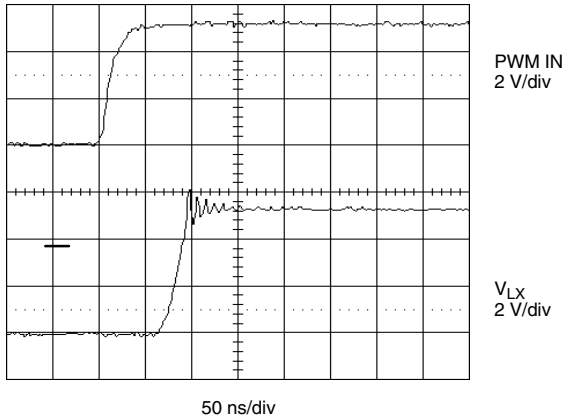

Figure 2. PWM Signal vs. LX (Rising)

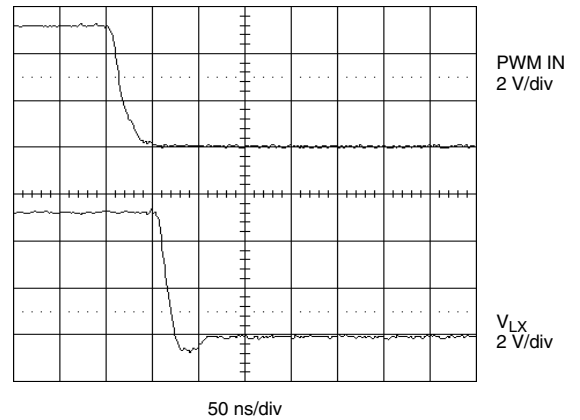

Figure 3. PWM Signal vs. LX (Falling)

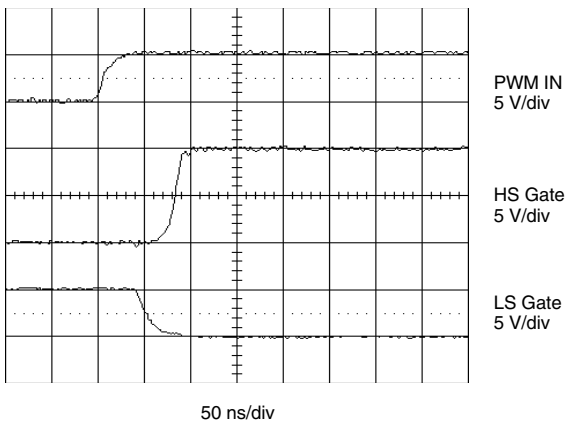

Figure 4. PWM Signal vs. HS Gate and LS Gate (Rising)

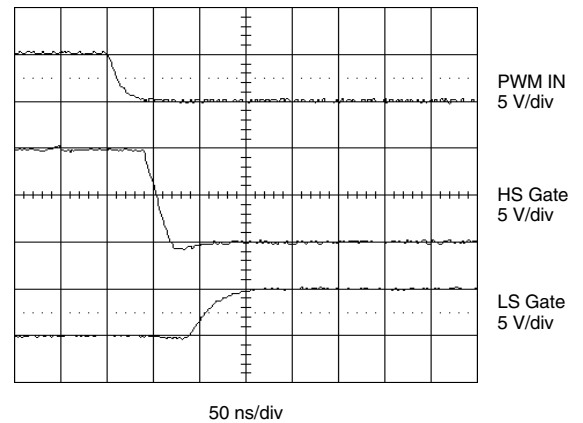

Figure 5. PWM Signal vs. HS Gate and LS Gate (Falling)

Vishay Siliconix maintains worldwide manufacturing capability. Products may be manufactured at one of several qualified locations. Reliability data for Silicon Technology and Package Reliability represent a composite of all qualified locations. For related documents such as package/tape drawings, part marking, and reliability data, see www.vishay.com/ppg?72706.



Disclaimer

ALL PRODUCT, PRODUCT SPECIFICATIONS AND DATA ARE SUBJECT TO CHANGE WITHOUT NOTICE TO IMPROVE RELIABILITY, FUNCTION OR DESIGN OR OTHERWISE.

Vishay Intertechnology, Inc., its affiliates, agents, and employees, and all persons acting on its or their behalf (collectively, "Vishay"), disclaim any and all liability for any errors, inaccuracies or incompleteness contained in any datasheet or in any other disclosure relating to any product.

Vishay makes no warranty, representation or guarantee regarding the suitability of the products for any particular purpose or the continuing production of any product. To the maximum extent permitted by applicable law, Vishay disclaims (i) any and all liability arising out of the application or use of any product, (ii) any and all liability, including without limitation special, consequential or incidental damages, and (iii) any and all implied warranties, including warranties of fitness for particular purpose, non-infringement and merchantability.

Statements regarding the suitability of products for certain types of applications are based on Vishay's knowledge of typical requirements that are often placed on Vishay products in generic applications. Such statements are not binding statements about the suitability of products for a particular application. It is the customer's responsibility to validate that a particular product with the properties described in the product specification is suitable for use in a particular application. Parameters provided in datasheets and/or specifications may vary in different applications and performance may vary over time. All operating parameters, including typical parameters, must be validated for each customer application by the customer's technical experts. Product specifications do not expand or otherwise modify Vishay's terms and conditions of purchase, including but not limited to the warranty expressed therein.

Except as expressly indicated in writing, Vishay products are not designed for use in medical, life-saving, or life-sustaining applications or for any other application in which the failure of the Vishay product could result in personal injury or death. Customers using or selling Vishay products not expressly indicated for use in such applications do so at their own risk and agree to fully indemnify and hold Vishay and its distributors harmless from and against any and all claims, liabilities, expenses and damages arising or resulting in connection with such use or sale, including attorneys fees, even if such claim alleges that Vishay or its distributor was negligent regarding the design or manufacture of the part. Please contact authorized Vishay personnel to obtain written terms and conditions regarding products designed for such applications.

No license, express or implied, by estoppel or otherwise, to any intellectual property rights is granted by this document or by any conduct of Vishay. Product names and markings noted herein may be trademarks of their respective owners.