



# STEVAL-ILL009V5

New RGB color demonstration board  
based on the STP04CM05 and ST1S10

Data Brief

## Features

- 3 A at 4 V DC-DC converter using the ST1S10 for input voltage range (7 V - 18 V)
- New improved LED drivers STP04CM05 and STP08CP05
- Input over-voltage protection done by Transil™ (SMAJ15A-TR)
- Protection against input voltage reversion

## Applications

- Adapters for PDAs, camcorders, electric shavers, cellular phones, videogames
- Auxiliary power supply for LCD/PDP TVs, monitors, audio systems, computers, industrial applications
- SMPS for set-top boxes
- DVD players/recorders, white goods

## Description

The STEVAL-ILL009V5 demonstration board was designed in order to allow evaluation and testing of the new DC-DC converter ST1S10 and new LED drivers STP04CM05 and STP08CP05. This board replaces the previous version STEVAL-ILL009V1. Thanks to the ST1S10 DC-DC converter, the size of the inductor and board dimensions are reduced. The dimensions of the STEVAL-ILL009V5 are 120 mm x 47 mm, instead of 151 mm x 47 mm for the STEVAL-ILL009V1. The input voltage for this board ranges from 7 V to 18 V. The new LED drivers allow faster communications and higher output voltage. Other features such as software, brightness and color regulation, microcontroller and temperature protection, are identical on both the STEVAL-ILL009V1 and the new STEVAL-ILL009V5.



# 1 Circuit schematic

Figure 1. LED drivers part

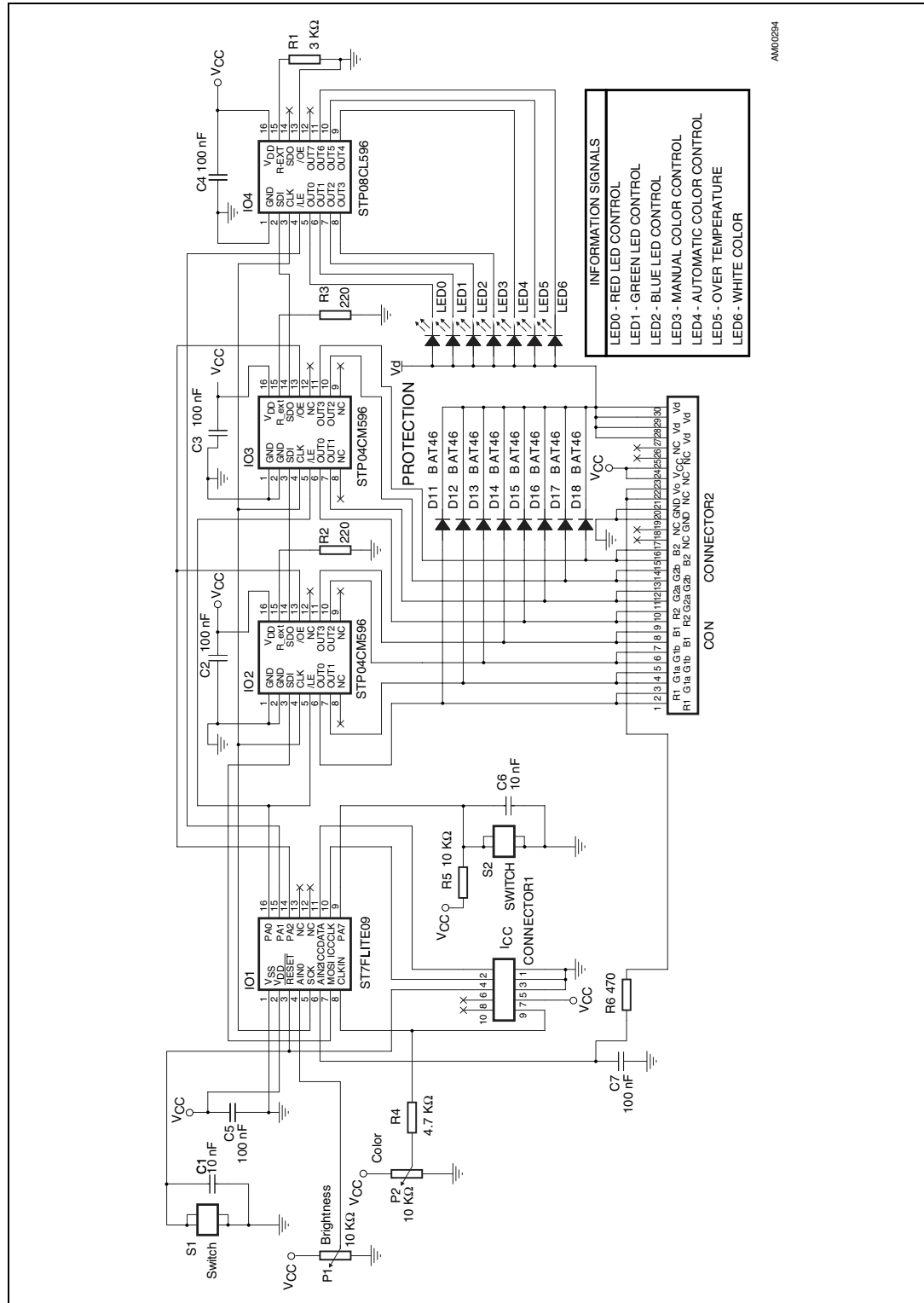
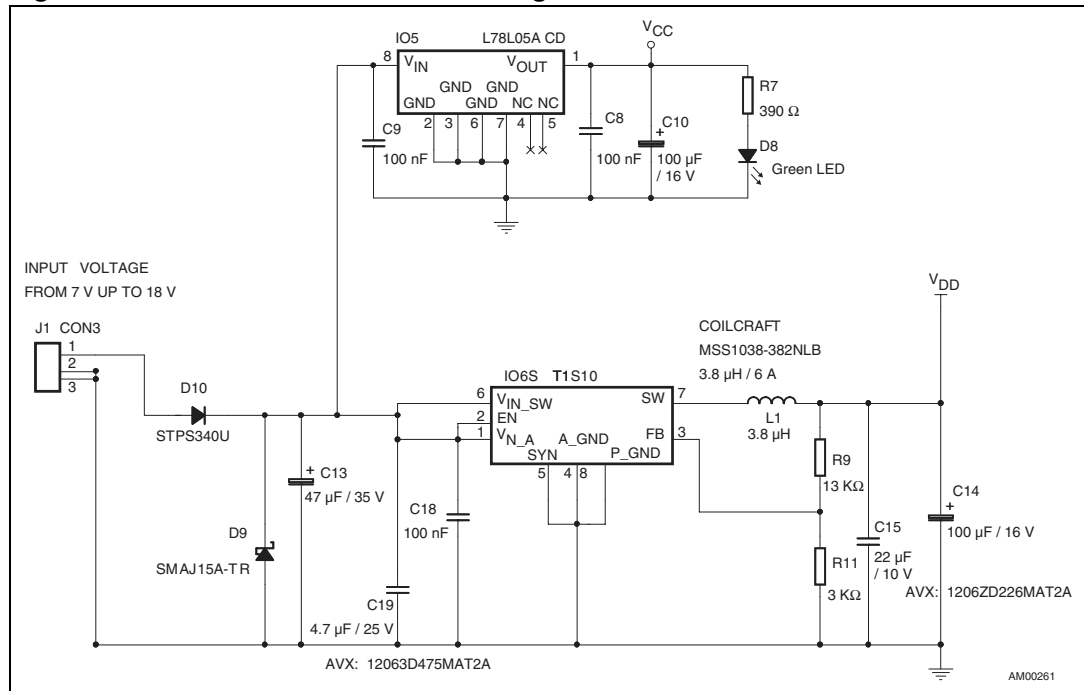

Figure 2. Power sources schematic diagram



## 2 Revision history

**Table 1. Document revision history**

Date	Revision	Changes
28-Oct-2008	1	Initial release

**Please Read Carefully:**

Information in this document is provided solely in connection with ST products. STMicroelectronics NV and its subsidiaries ("ST") reserve the right to make changes, corrections, modifications or improvements, to this document, and the products and services described herein at any time, without notice.

All ST products are sold pursuant to ST's terms and conditions of sale.

Purchasers are solely responsible for the choice, selection and use of the ST products and services described herein, and ST assumes no liability whatsoever relating to the choice, selection or use of the ST products and services described herein.

No license, express or implied, by estoppel or otherwise, to any intellectual property rights is granted under this document. If any part of this document refers to any third party products or services it shall not be deemed a license grant by ST for the use of such third party products or services, or any intellectual property contained therein or considered as a warranty covering the use in any manner whatsoever of such third party products or services or any intellectual property contained therein.

**UNLESS OTHERWISE SET FORTH IN ST'S TERMS AND CONDITIONS OF SALE ST DISCLAIMS ANY EXPRESS OR IMPLIED WARRANTY WITH RESPECT TO THE USE AND/OR SALE OF ST PRODUCTS INCLUDING WITHOUT LIMITATION IMPLIED WARRANTIES OF MERCHANTABILITY, FITNESS FOR A PARTICULAR PURPOSE (AND THEIR EQUIVALENTS UNDER THE LAWS OF ANY JURISDICTION), OR INFRINGEMENT OF ANY PATENT, COPYRIGHT OR OTHER INTELLECTUAL PROPERTY RIGHT.**

**UNLESS EXPRESSLY APPROVED IN WRITING BY AN AUTHORIZED ST REPRESENTATIVE, ST PRODUCTS ARE NOT RECOMMENDED, AUTHORIZED OR WARRANTED FOR USE IN MILITARY, AIR CRAFT, SPACE, LIFE SAVING, OR LIFE SUSTAINING APPLICATIONS, NOR IN PRODUCTS OR SYSTEMS WHERE FAILURE OR MALFUNCTION MAY RESULT IN PERSONAL INJURY, DEATH, OR SEVERE PROPERTY OR ENVIRONMENTAL DAMAGE. ST PRODUCTS WHICH ARE NOT SPECIFIED AS "AUTOMOTIVE GRADE" MAY ONLY BE USED IN AUTOMOTIVE APPLICATIONS AT USER'S OWN RISK.**

Resale of ST products with provisions different from the statements and/or technical features set forth in this document shall immediately void any warranty granted by ST for the ST product or service described herein and shall not create or extend in any manner whatsoever, any liability of ST.

ST and the ST logo are trademarks or registered trademarks of ST in various countries.

Information in this document supersedes and replaces all information previously supplied.

The ST logo is a registered trademark of STMicroelectronics. All other names are the property of their respective owners.

© 2008 STMicroelectronics - All rights reserved

STMicroelectronics group of companies

Australia - Belgium - Brazil - Canada - China - Czech Republic - Finland - France - Germany - Hong Kong - India - Israel - Italy - Japan - Malaysia - Malta - Morocco - Singapore - Spain - Sweden - Switzerland - United Kingdom - United States of America

[www.st.com](http://www.st.com)