

NEVO series PSUs are modular and user configurable power supplies offering unrivalled performance and flexibility. Standard output modules cover voltages from 1.5V_{DC} to 58V_{DC} and can deliver up to 25A per module. The capability to series and/or parallel outputs in any combination results in a flexible power delivery platform that is suitable for almost all applications.

Output modules 1 to 4 also come with full range analog remote control of both voltage and current as standard and now with the release of the new I²C interface, NEVO series outputs can be easily controlled using low cost microcontrollers.

The I²C interface plugs directly into each output module and provides a standard I²C bus as an alternative to the normal analog controls. The interface connects to J5 on the output module and provides a similar socket for connection to the user application as shown below.

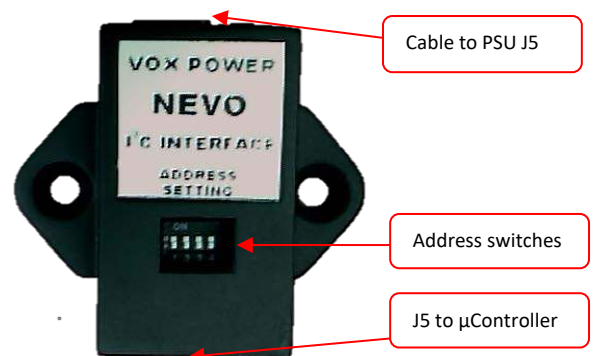
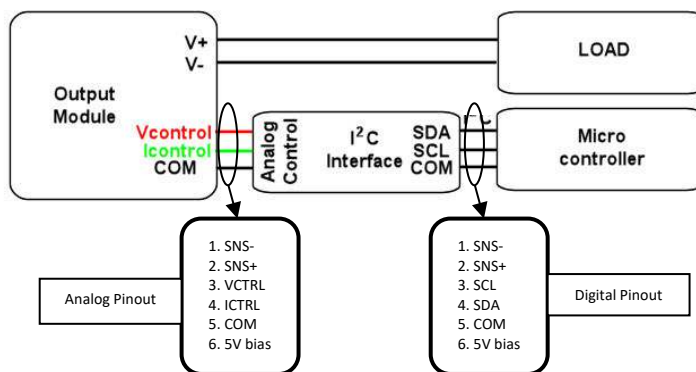

The output voltage and current limit can then be controlled in +/-127 steps that are programmed through the I²C interface. Careful consideration must be given to system grounding as the interface is not isolated and must be referenced to the COM pin on J5. Incorrect system grounding may cause damage to the unit. Adhere to the same precautions as for "Local bias supply" detailed on page 16 of the user manual or contact Vox Power for assistance.

I²C slave address

Each interface can be programmed to any one of four slave addresses via on-board dip switches.

Switch setting (1=ON, 0=OFF, X=Don't care)				Slave Address
1	2	3	4	
0	0	X	X	20h
0	1	X	X	60h
1	0	X	X	A0h
1	1	X	X	E0h

Memory Organization

Memory address	Control function
F8h	Voltage
F9h	Current

Register format

Sign	MSB						LSB
S	D ₆	D ₅	D ₄	D ₃	D ₂	D ₁	D ₀

S = sign bit (0b) [1 = Positive, 0 = Negative]

D_x = 7 bit data (0000000b)

() indicates power on default.

I²C protocol and timing diagrams are available on request.

Ordering information

Order NEVO I²C

Voltage control

Memory address = F8h

Adjust range = +/-100% of voltage set with potentiometer

Adjust resolution = +/-7 bit (0.4% steps)

Power on setting = 0% adjust (eg. $V_{out} = V_{set}$)

Control equations:

$$V_{out} = V_{set} * (1 - (\text{Data} / 116.27)) \quad [1]$$

or

$$\text{Data} = 116.27 * (1 - (V_{out} / V_{set})) \quad [2]$$

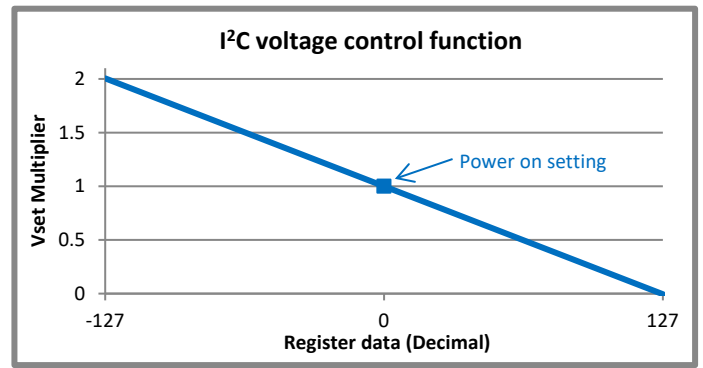

Example 1: OP1, $V_{set} = 5V$, $V_{adjust} = 2V$, I²C address = 20h, Voltage adjust register = F8h

Use equation 2 to find the required data: $116.27 * (1 - (2/5)) = +70$

Set sign bit (Bit 8 = 1 for positive numbers, 0 for negative numbers): +70 => 198 (C6h)

Equation 1 will give the quantized setting: $V_{out} = 5 * (1 - (70/116.27)) = 1.989V$

Send the following data over the I²C bus:

I ² C address	Register	Data
20h	F8h	C6h

Example 2: OP2, $V_{set} = 6V$, $V_{adjust} = 12V$, I²C address = 60h, Voltage adjust register = F8h

Use equation 2 to find the required data: $116.27 * (1 - (12/6)) = -116$

Set sign bit (Bit 8 = 1 for positive numbers, 0 for negative numbers): -116 => -116 (74h)

Equation 1 will give the quantized setting: $V_{out} = 6 * (1 - (-116/116.27)) = 11.986V$

Send the following data over the I²C bus:

I ² C address	Register	Data
60h	F8h	74h

Current control

Memory address = F9h

Adjust range = 0 to 110% of rated current

Adjust resolution = +/-7 bit (0.38% I_{rated} steps)

Power on setting = $0.6 * I_{rated}$

Control equations:

$$I_{out} = I_{rated} * (0.711 + \text{Data} / 166.66) \quad [1]$$

or

$$\text{Data} = 166.66 * (I_{out} / I_{rated} - 0.711) \quad [2]$$

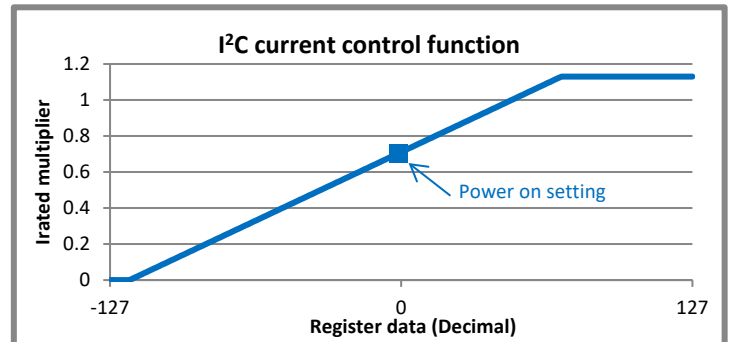

Example 1:

Setup: OP1, $I_{rated} = 25A$, $I_{adjust} = 10A$, I²C address = 20h, Current adjust register = F9h

Use equation 2 to find the required data: $166.66 * (10/25 - 0.711) = -52$

Set sign bit (Bit 8 = 1 for positive numbers, 0 for negative numbers): -52 => -52 (34h)

Equation 1 will give the quantized setting: $I_{out} = 25 * (0.711 + (-52/166.66)) = 9.974A$

Send the following data over the I²C bus:

I ² C address	Register	Data
20h	F9h	D7h

Example 2:

Setup: OP3, $I_{rated} = 7.5A$, $I_{adjust} = 6A$, I²C address = A0h, Current adjust register = F9h

Use equation 2 to find the required data: $166.66 * (6/7.5 - 0.711) = +15$

Set sign bit (Bit 8 = 1 for positive numbers, 0 for negative numbers): +15 => 143 (8Fh)

Equation 1 will give the quantized setting: $I_{out} = 7.5 * (0.711 + 15/166.66) = 6.007A$

Send the following data over the I²C bus:

I ² C address	Register	Data
A0h	F9h	8Fh