

10091836 - X0J - XXXLF

4-COLUMN DIFFERENTIAL SIGNAL

LEAD-FREE DESIGNATION ONLY WITH APPLICABLE PLATING CODES

LETTER	PERFORMANCE-BASED PLATING (SEE NOTE 2)	
	TARGET APPLICATION	LEAD FREE (LF)
B	TELCORDIA CO	NO
C	TELCORDIA UE	NO
D	TELCORDIA CO	YES
E	TELCORDIA UE	YES

NUMBER	PIN STYLE, HEIGHT
0	STANDARD GUIDE PIN MACHINED, 31.6mm
4	STANDARD GUIDE PIN MACHINED, 25.7mm

MODULE DESCRIPTION	LETTER DESIGNATION REPRESENTED IN DASH NUMBER										BASE MODULE
LEFT POLARIZING GUIDANCE MODULE (SEE SHEET 3)	<b>J</b>	<b>A</b>	<b>B</b>	<b>C</b>	<b>D</b>	<b>E</b>	<b>F</b>	<b>G</b>	<b>H</b>		
RIGHT POLARIZING GUIDANCE MODULE (SEE SHEET 4)	<b>Y</b>	<b>P</b>	<b>Q</b>	<b>R</b>	<b>S</b>	<b>T</b>	<b>U</b>	<b>V</b>	<b>W</b>		
OPEN MODULE (TWO WALL) (SEE SHEET 2)	<b>0 (ZERO)</b>										
LEFT WALL MODULE (SEE SHEET 5)	<b>L</b>										
RIGHT WALL MODULE (SEE SHEET 6)	<b>M</b>										
FOUR WALL MODULE (SEE SHEET 7)	<b>1</b>										

NUMBER	CONTACT MATING WIPE LENGTH		COMPLIANT PIN DRILL SIZE
	SIGNAL	WIDE GROUND	
1	2	4	Ø0.55 [0.0217"]
2	3	4	Ø0.55 [0.0217"]
3	2	4	Ø0.45 [0.0177"]
4	3	4	Ø0.45 [0.0177"]
5	2	3	Ø0.55 [0.0217"]
6	3	3	Ø0.55 [0.0217"]
7	2	3	Ø0.45 [0.0177"]
8	3	3	Ø0.45 [0.0177"]

	GROUNDED	UNGROUNDED
FINISHED	Ø2.35-2.55	Ø2.35-2.55
PAD	Ø5.50	N/A
PLATED	YES	NO
DRILL (mm/in)	2.58 / .1015	2.44 / .096

SCREW P/N	DESCRIPTION	BOARD THICKNESS
10091790-002LF	#2-56 X .375" PHILLIPS PANHEAD W/SQ CONICAL WASHER	1.60 - 5.00
10091790-003LF	#2-56 X .500" PHILLIPS PANHEAD W/SQ CONICAL WASHER	5.00 - 10.00

spec ref	SEE NOTES	dr	Jim Swain	2010/04/13	projection	MM	size	A2	scale	4:1	
tolerance std	ASME Y14.5	eng	Michael Song	2016/06/06	chr	Heaven Cen	2016/06/08	ecn no	ELX-DG-24191-1	rel level	Released
surface	linear	0.X	±0.2	0.XX	±0.10	0.XXX	±0.050	product family	Module Assembly	cat. no.	10091836
ASME Y14.5	angular	0°	±°	Amphenol FCI		VERTICAL HEADER, 4-COLUMN, 4-PAIR		Product - Customer Drw	sheet 1 of 8	rev	G

Amphenol FCI

© 2016 AFCI

# OPEN (2-WALL) MODULE

SEE NOTE 8

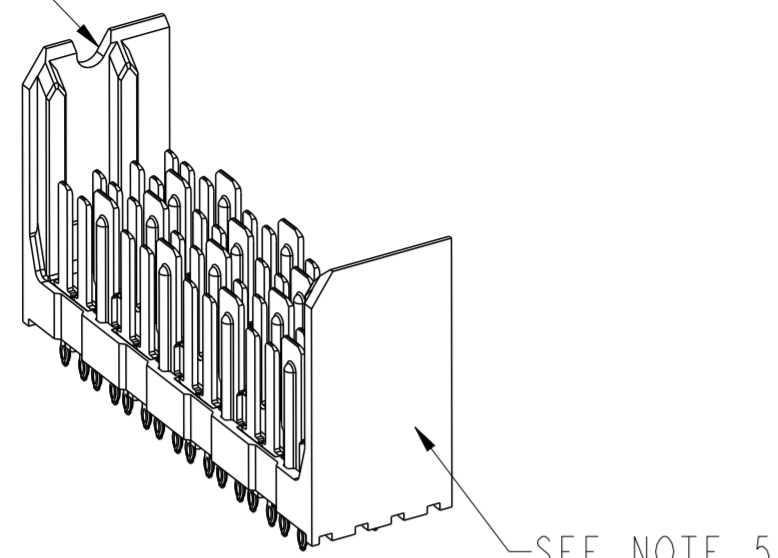

SEE NOTE 5

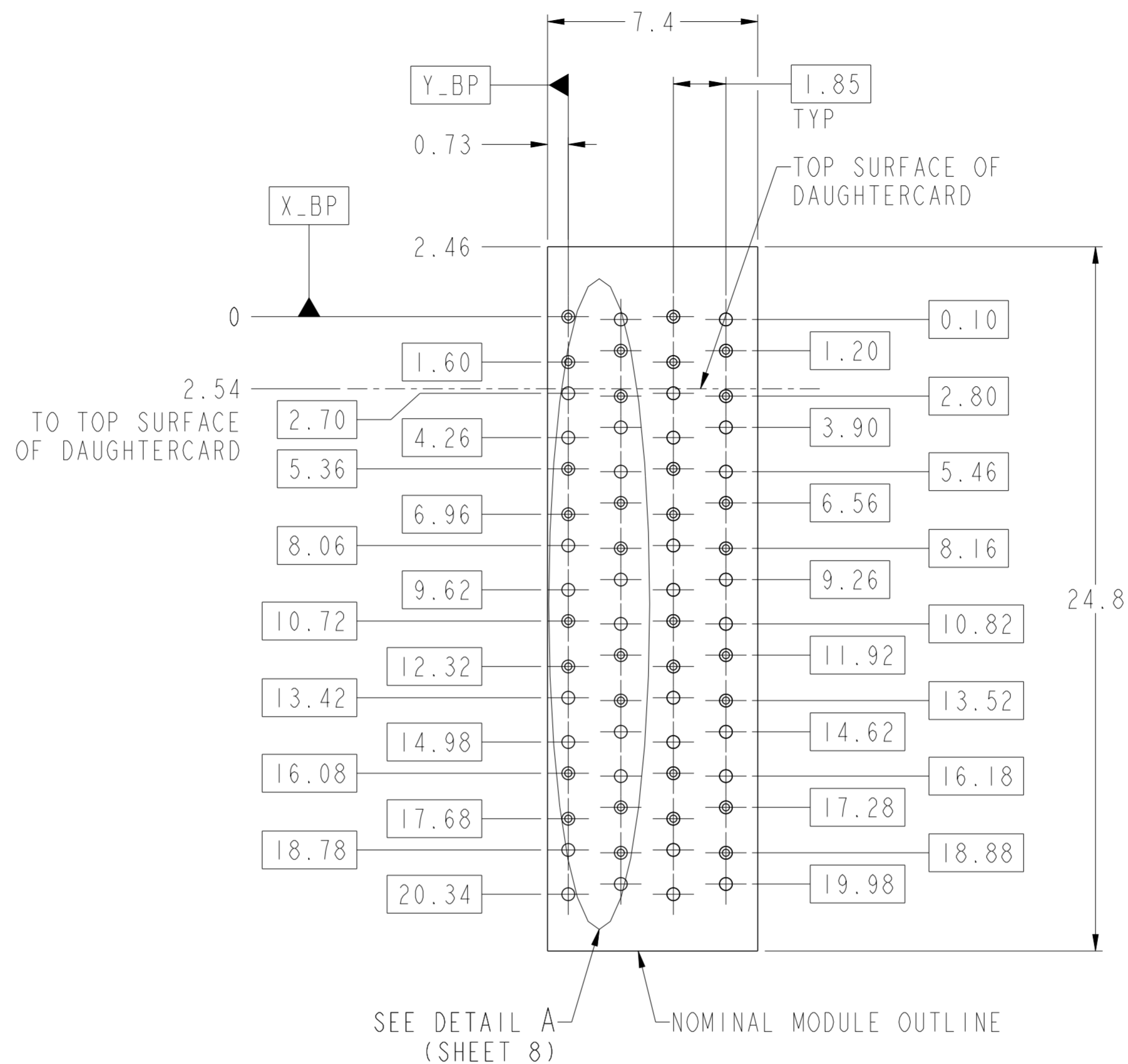
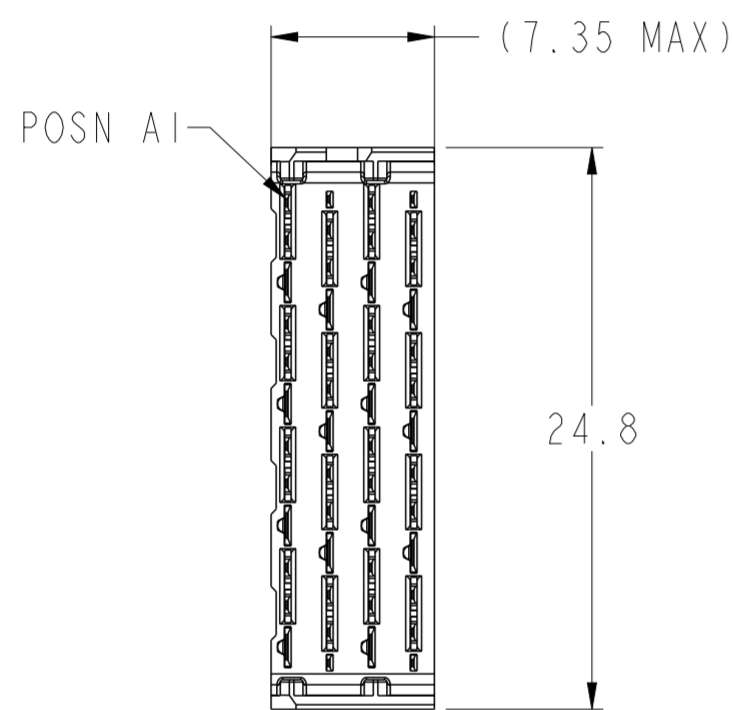

SEE DETAIL A (SHEET 8)

PCB HOLE PATTERN  
COMPONENT SIDE  
SCALE 6:1

- 6.2 (4MM WIPE WIDE GROUNDS)
- 5.2 (3MM WIPE WIDE GROUNDS)
- 5.2 (3MM SMALL END GROUNDS)
- 5.2 (3MM WIPE SIGNALS)
- 4.2 (2MM WIPE SIGNALS)
- SEE P/N TREE

2.64±0.10 FROM STANDOFF  
SURFACE TO MATING SURFACE

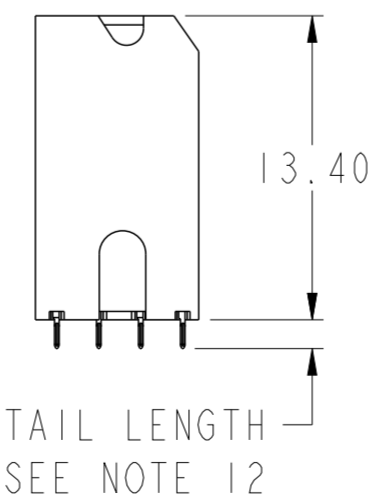
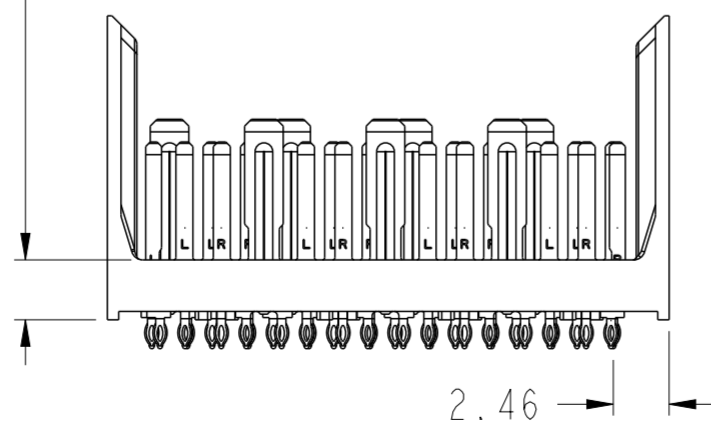
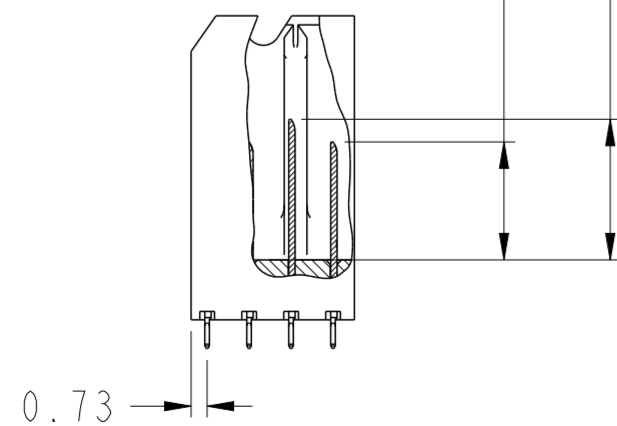

spec ref	SEE NOTES	dr	Jim Swain	2010/04/13	projection	MM	size	A2	scale	4:1
tolerance std	TOLERANCES UNLESS OTHERWISE SPECIFIED	eng	Michael Song	2016/06/06			ecn no	ELX-DG-24191-1	rel level	Released
ASME Y14.5		chr	Heaven Cen	2016/06/08						
surface	linear	0.X	±0.2		MODULE ASSEMBLY VERTICAL HEADER, 4-COLUMN, 4-PAIR	drg no 10091836	rev G			
		0.XX	±0.10							
		0.XXX	±0.050							
ASME Y14.5	angular	0°	±°	cat. no.	-	Product - Customer Drw	sheet 2 of 8			

PDS: Rev :G

STATUS:Released

Printed: Jun 15, 2016

# LEFT POLARIZING/GUIDE MODULE

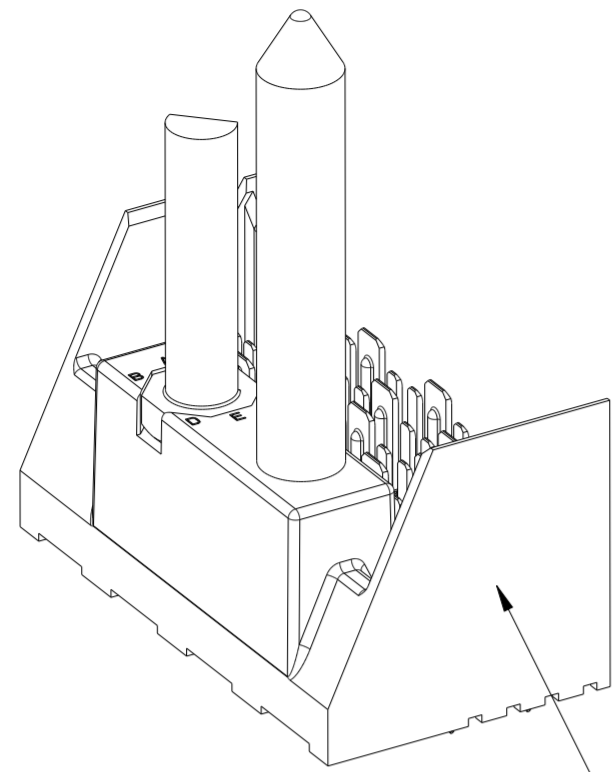

SEE NOTE 5

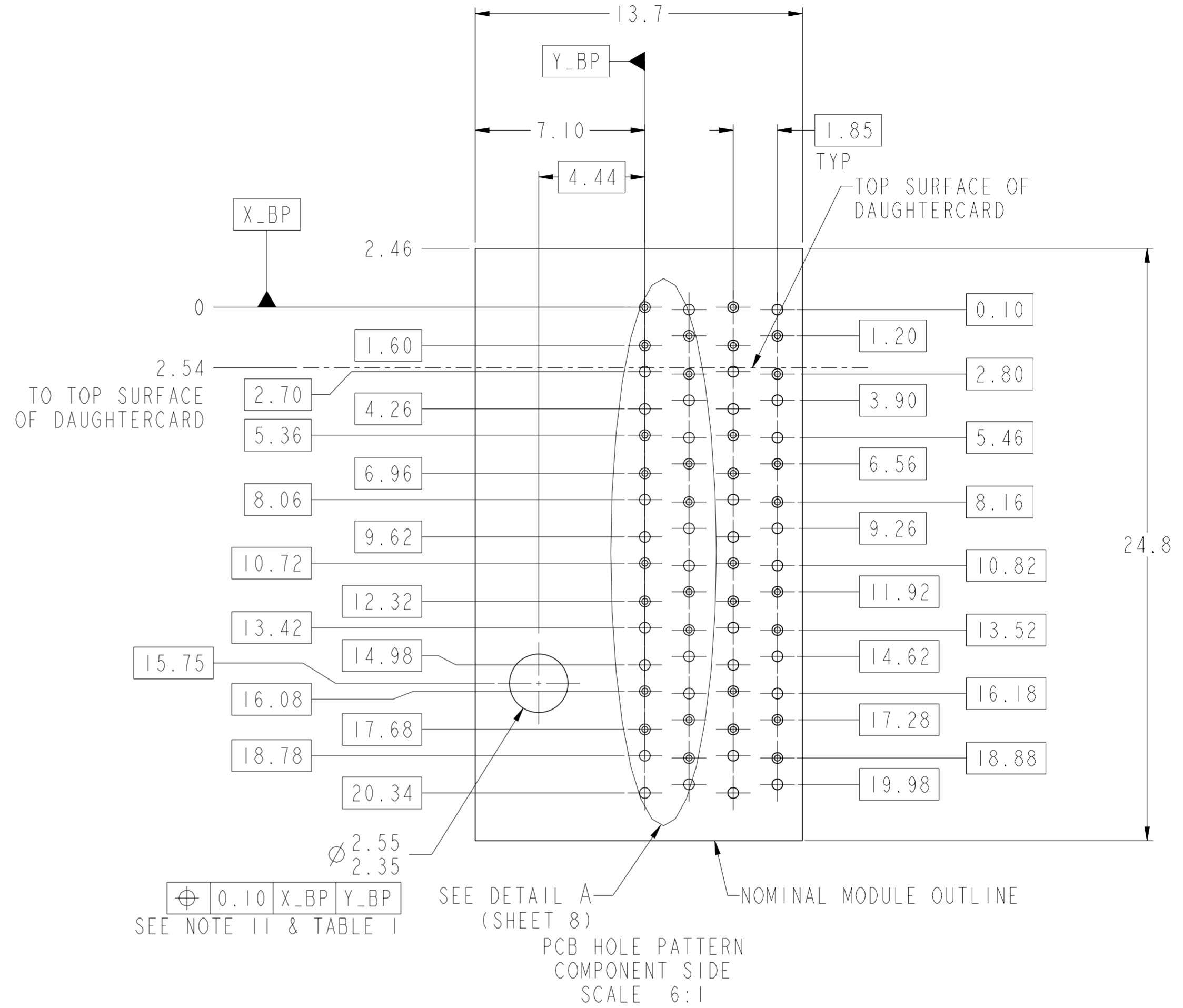
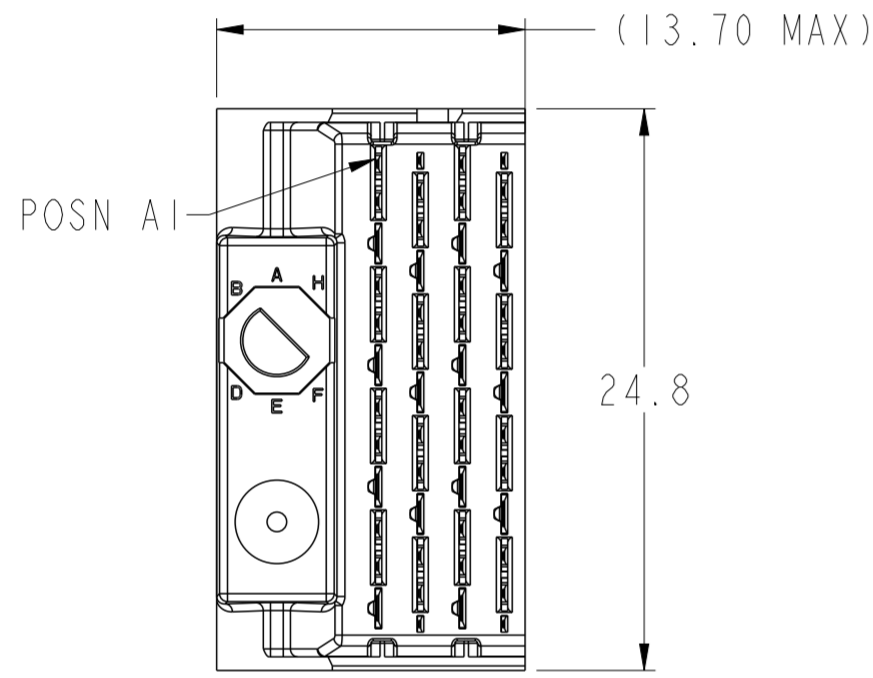

$\varnothing$ 0.10	X_BP	Y_BP
--------------------	------	------

SEE NOTE 11 & TABLE 1

- 6.2 (4MM WIPE WIDE GROUNDS)
  - 5.2 (3MM WIPE WIDE GROUNDS)
  - 5.2 (3MM SMALL END GROUNDS)
  - 5.2 (3MM WIPE SIGNALS)
  - 4.2 (2MM WIPE SIGNALS)
- SEE P/N TREE

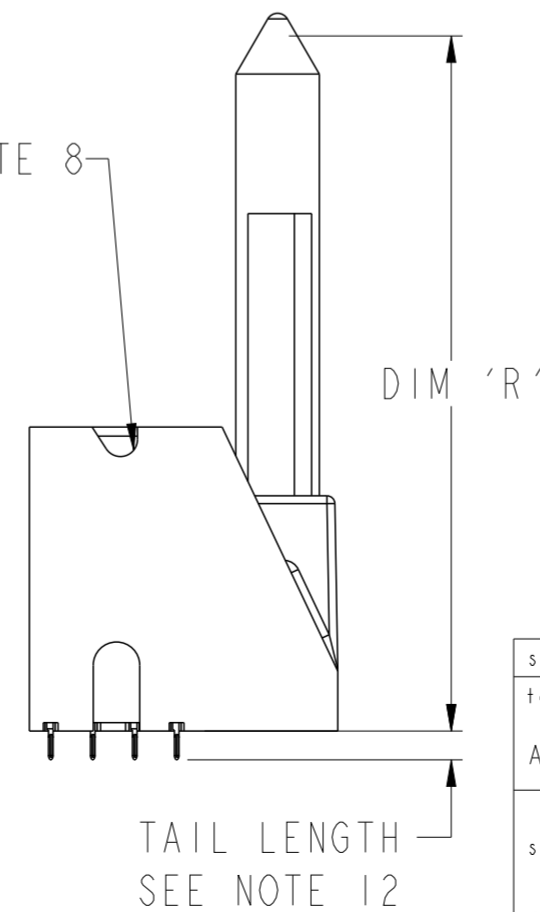
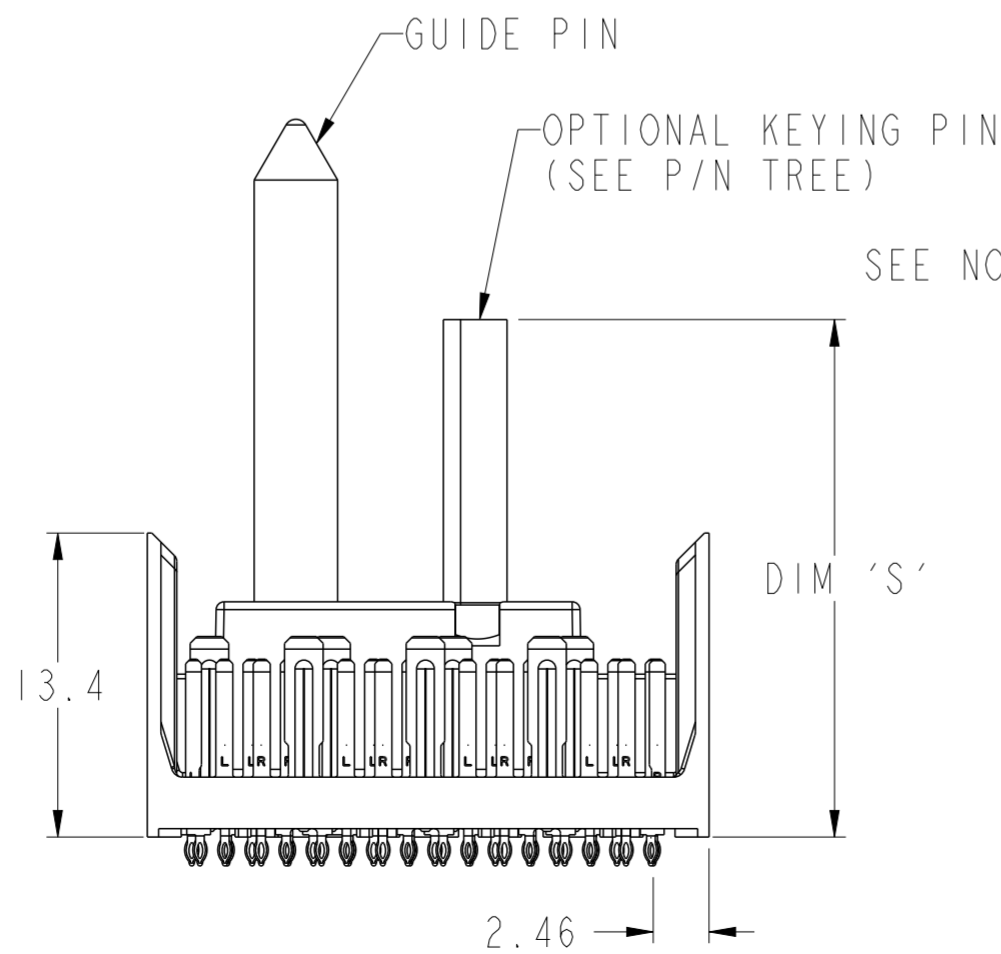
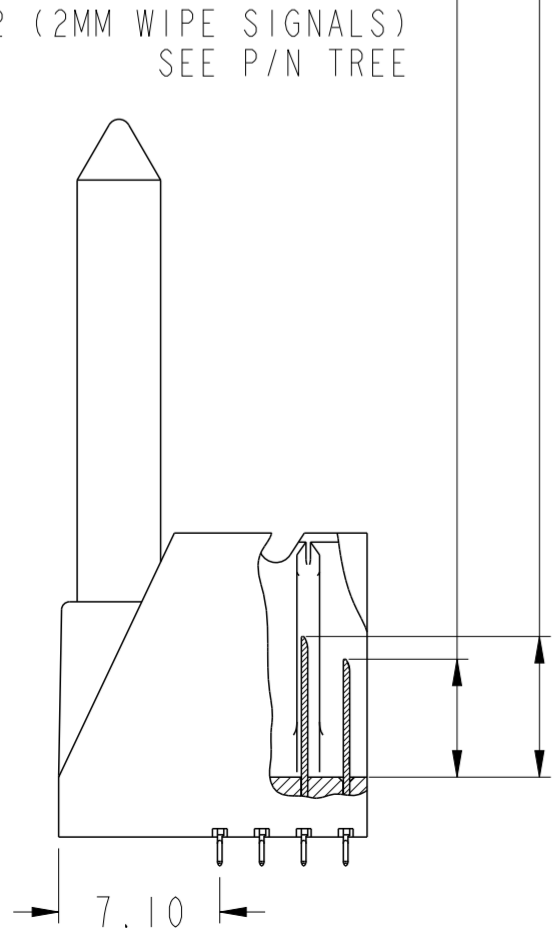

ASSEMBLY BASE CONFIGURATION END DASH NO.	GUIDE PIN	POLARIZING KEY
	DIM 'R'	DIM 'S'
-X0X	31.6mm	22.8mm
-X4X	25.7mm	20.0mm

spec ref	SEE NOTES	dr	Jim Swain	2010/04/13	projection	MM	size	A2	scale	3:1	
tolerance std	TOLERANCES UNLESS OTHERWISE SPECIFIED	eng	Michael Song	2016/06/06		Product family	XCede	rel level	Released	ecn no	ELX-DG-24191-1
ASME Y14.5		chr	Heaven Cen	2016/06/08							
surface	linear	0.X	±0.2	Amphenol FCi	MODULE ASSEMBLY	cat. no.	SEE P/N TREE	Product - Customer Drw	sheet 3 of 8	rev	G
		0.XX	±0.10								
ASME Y14.5	angular	0.XXX	±0.050								
		0°	±°								

# RIGHT POLARIZING/GUIDE MODULE

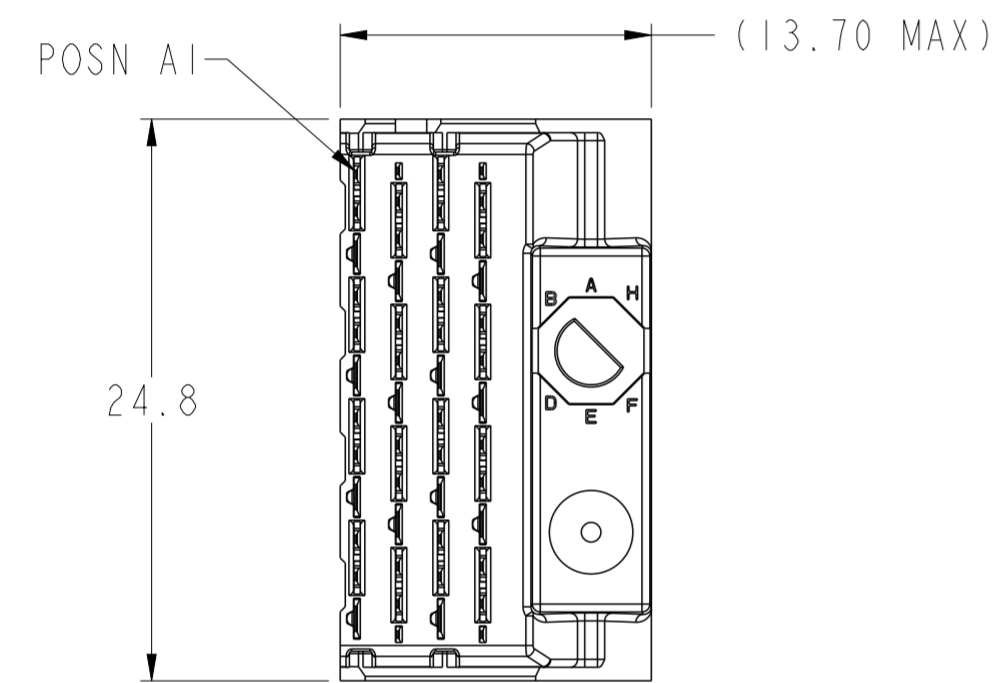
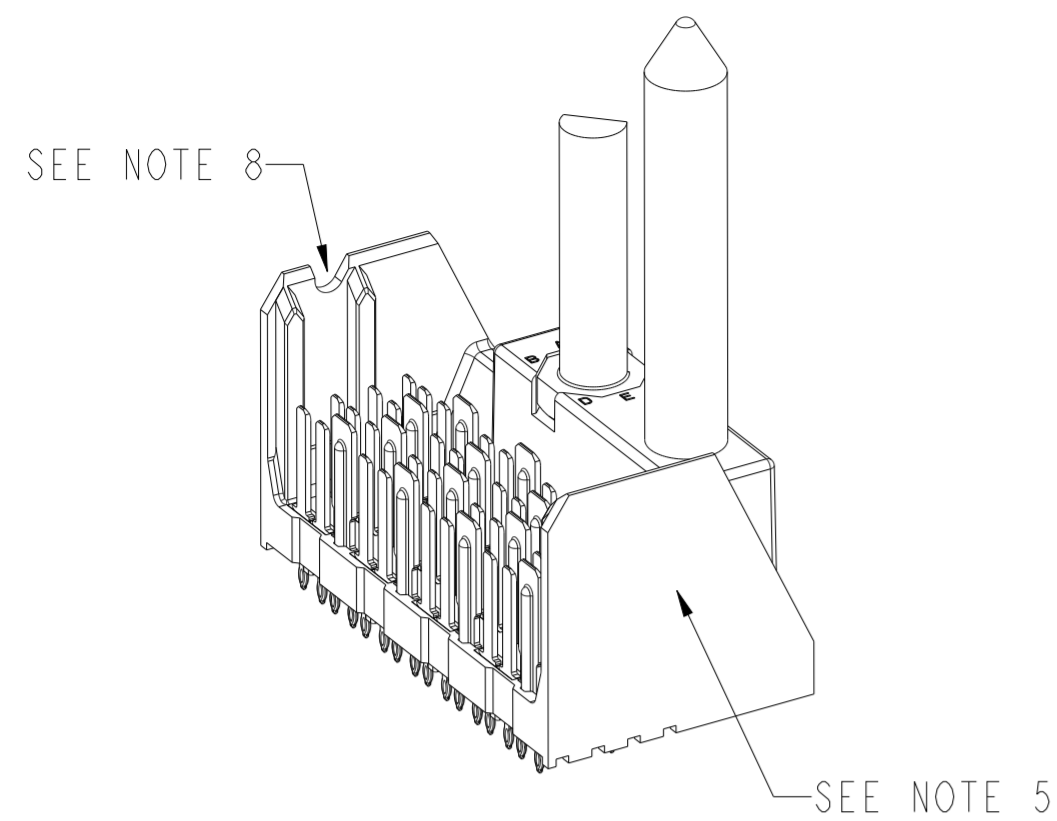

- 6.2 (4MM WIPE WIDE GROUNDS)
- 5.2 (3MM WIPE WIDE GROUNDS)
- 5.2 (3MM SMALL END GROUNDS)
- 5.2 (3MM WIPE SIGNALS)
- 4.2 (2MM WIPE SIGNALS)
- SEE P/N TREE

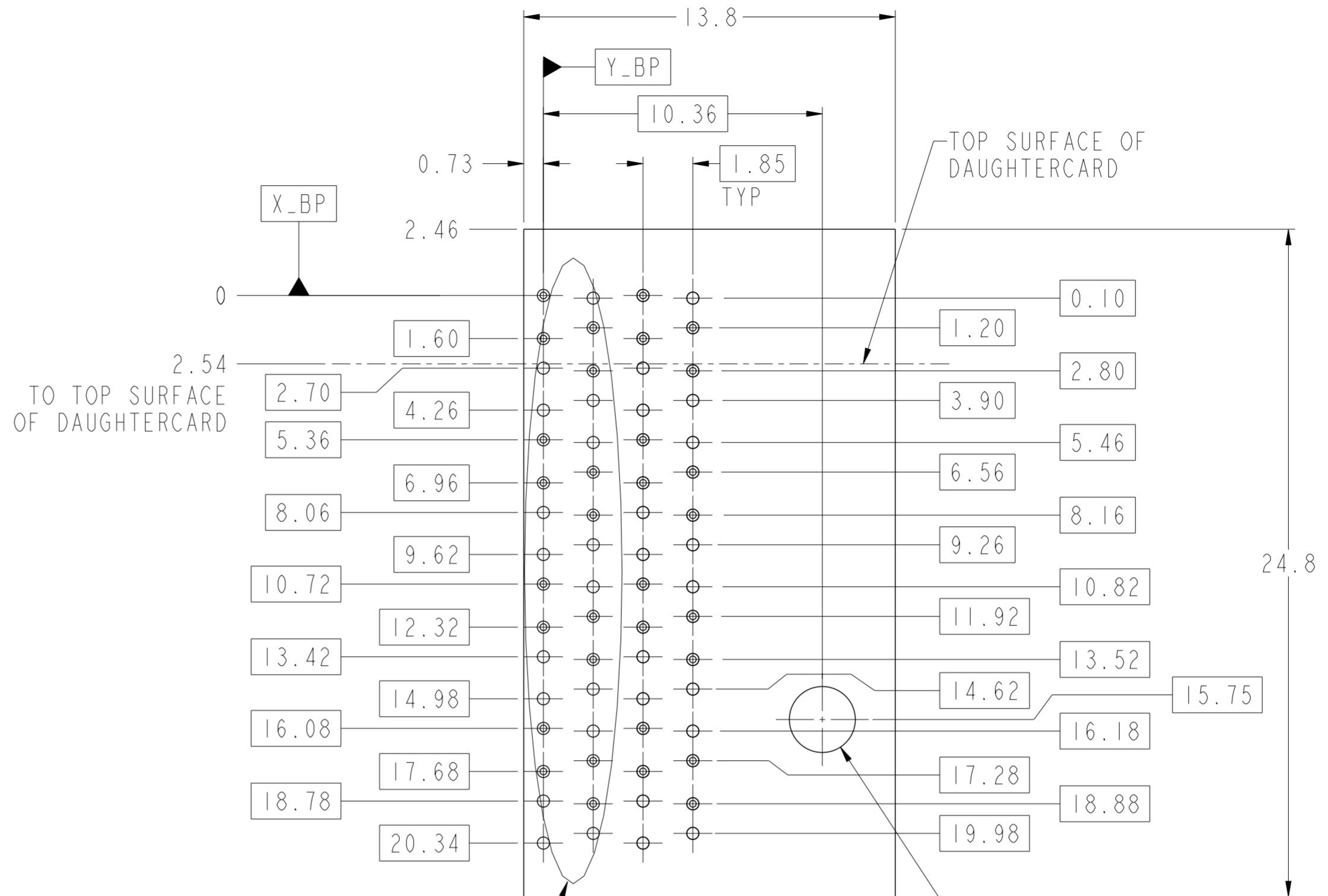
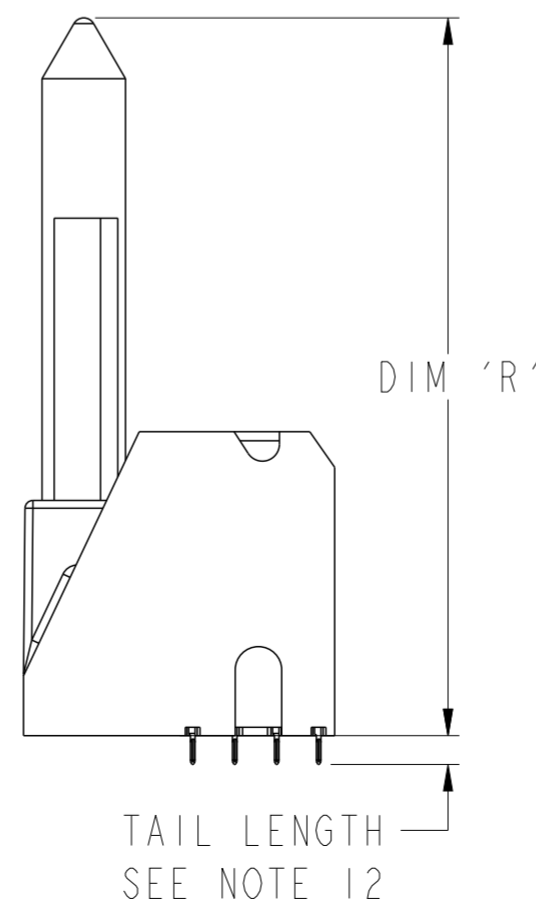
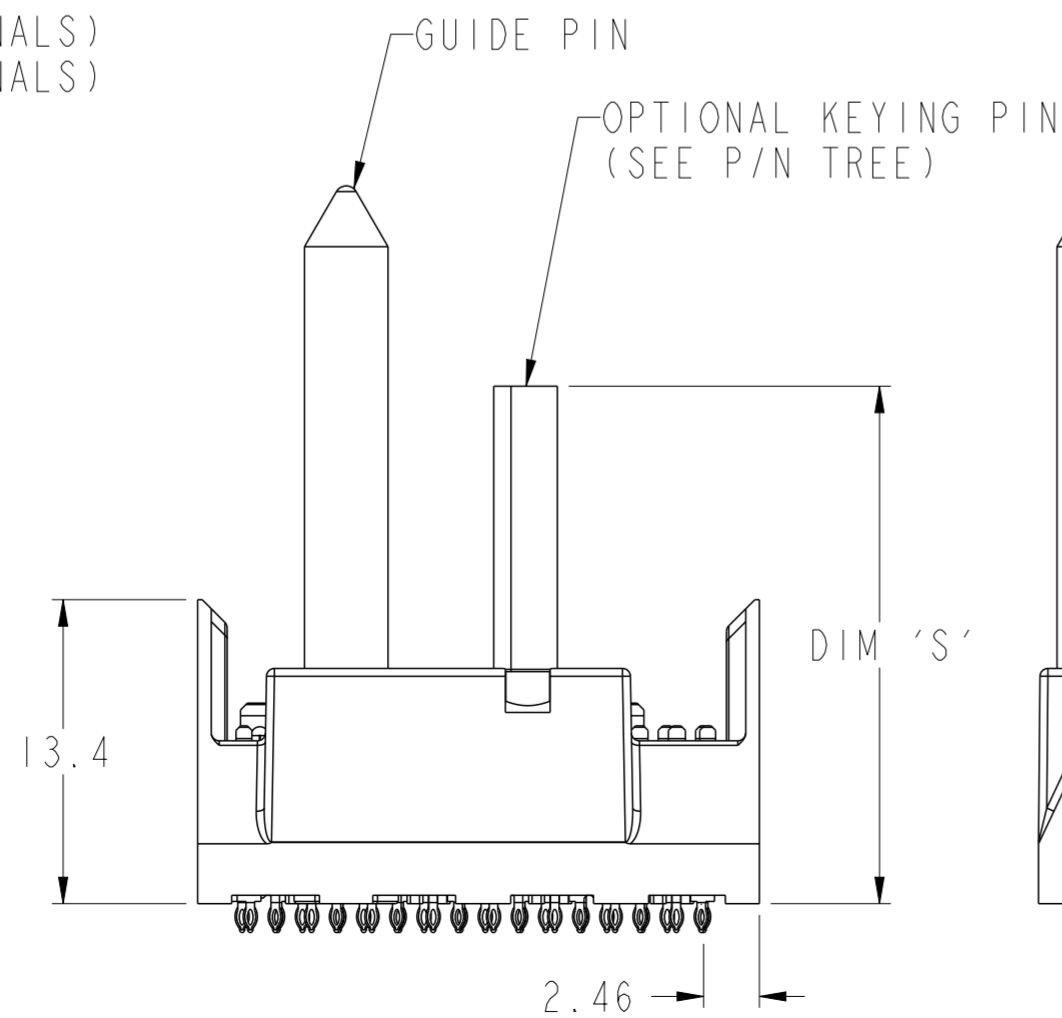
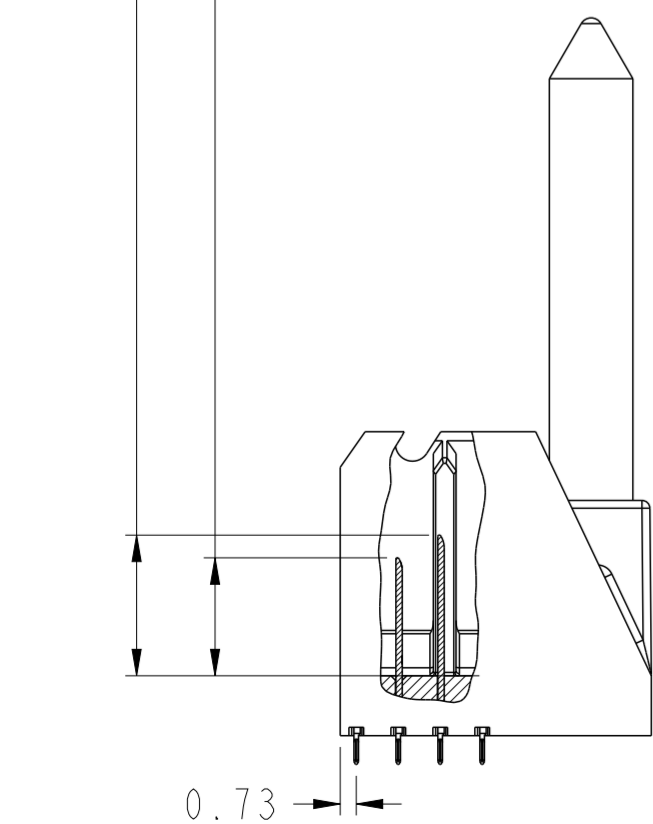

SEE DETAIL A (SHEET 8) NOMINAL MODULE OUTLINE  $\varnothing 2.55$   $\varnothing 2.35$

PCB HOLE PATTERN COMPONENT SIDE SCALE 6:1

$\varnothing 0.10$	X_BP	Y_BP
--------------------	------	------

SEE NOTE 11 & TABLE 1

ASSEMBLY BASE CONFIGURATION END DASH NO.	GUIDE PIN	POLARIZING KEY
	DIM 'R'	DIM 'S'
-X0X	31.6mm	22.8mm
-X4X	25.7mm	20.0mm

spec ref	SEE NOTES	dr	Jim Swain	2010/04/13	projection	MM	size	A2	scale	3:1
tolerance std	TOLERANCES UNLESS OTHERWISE SPECIFIED	eng	Michael Song	2016/06/06			ecn no	ELX-DG-24191-1	rel level	Released
ASME Y14.5		chr	Heaven Cen	2016/06/08						
surface	linear	0.X	$\pm 0.2$		MODULE ASSEMBLY VERTICAL HEADER, 4-COLUMN, 4-PAIR	cat. no. SEE P/N TREE	Product - Customer Drw	sheet 4 of 8	rev G	
		0.XX	$\pm 0.10$							
ASME Y14.5	angular	0.XXX	$\pm 0.050$							

# LEFT WALL MODULE

SEE NOTE 8

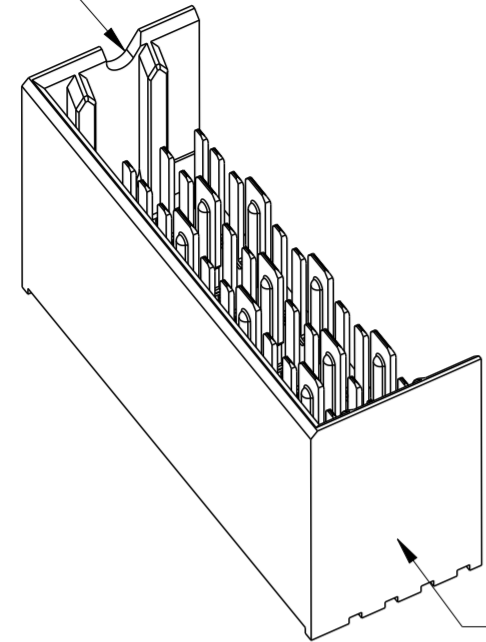

SEE NOTE 5

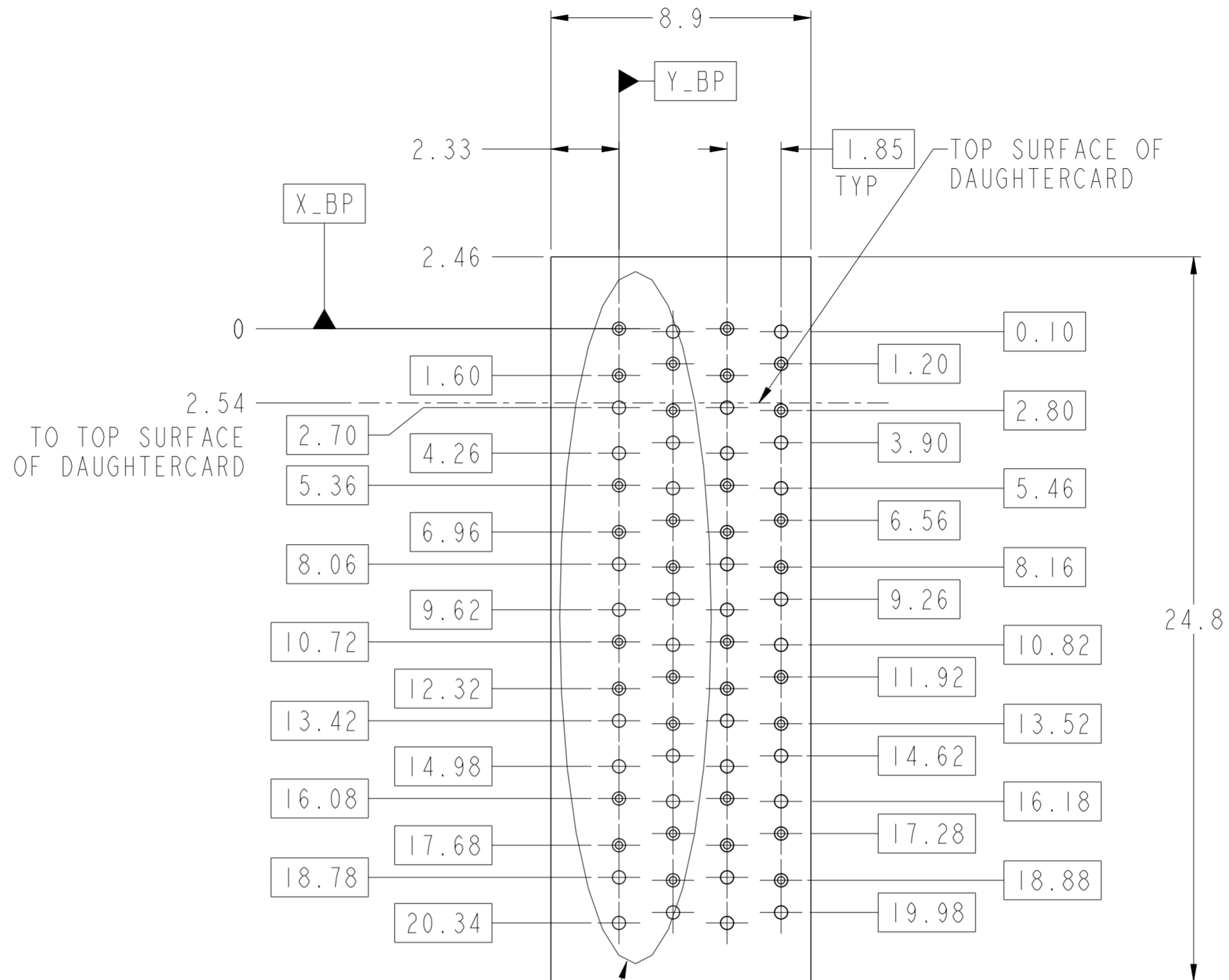

SEE DETAIL A (SHEET 8)

PCB HOLE PATTERN  
COMPONENT SIDE  
SCALE 6:1

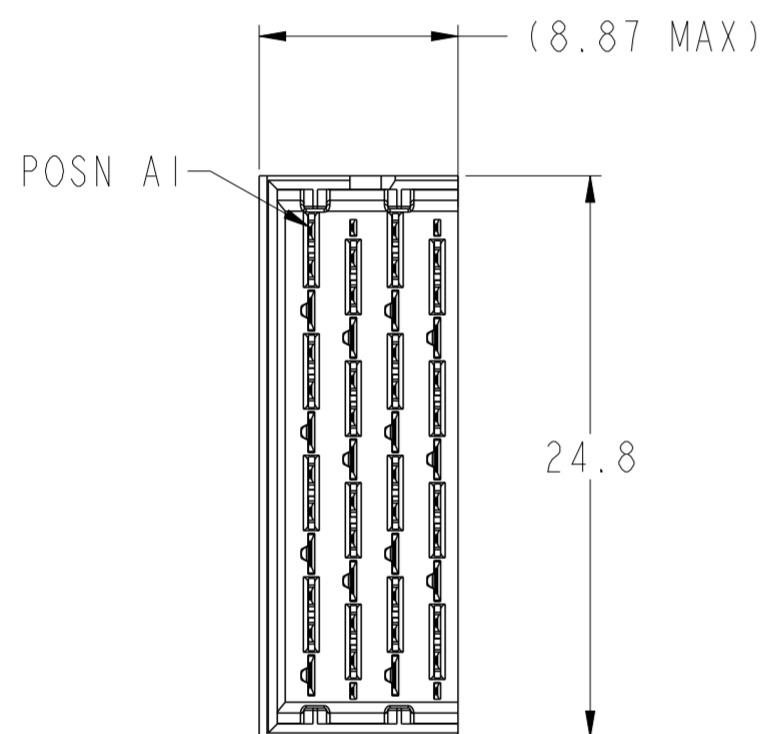

- 6.2 (4MM WIPE WIDE GROUNDS)
- 5.2 (3MM WIPE WIDE GROUNDS)
- 5.2 (3MM SMALL END GROUNDS)
- 5.2 (3MM WIPE SIGNALS)
- 4.2 (2MM WIPE SIGNALS)
- SEE P/N TREE

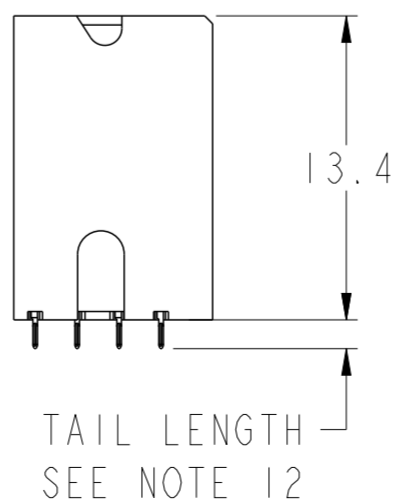
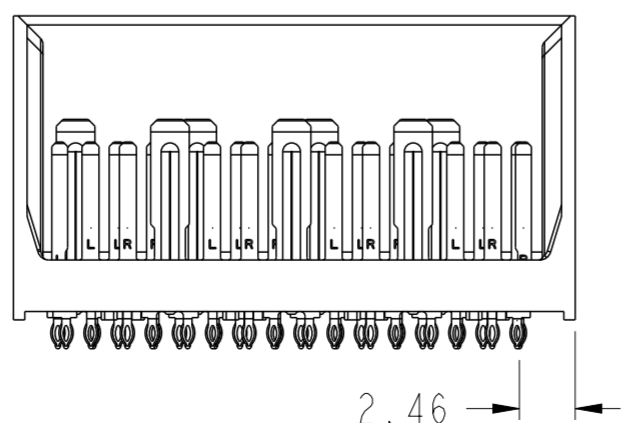
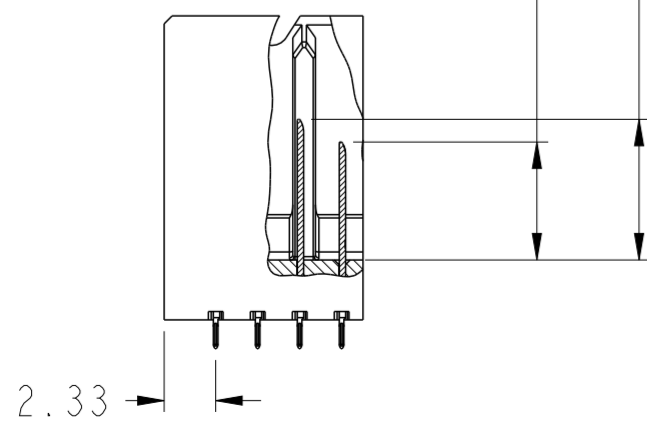

spec ref	SEE NOTES	dr	Jim Swain	2010/04/13	projection	MM	size	A2	scale	3:1		
tolerance std	ASME Y14.5	eng	Michael Song	2016/06/06			ecn no	ELX-DG-24191-1	rel level	Released		
TOLERANCES UNLESS OTHERWISE SPECIFIED		chr	Heaven Cen	2016/06/08			product family	XCede	cat. no.	SEE P/N TREE	Product - Customer Drw	sheet 5 of 8
surface	ASME Y14.5	appr	Pai-Ming Zheng	2016/06/15			module assembly	VERTICAL HEADER, 4-COLUMN, 4-PAIR	dwg no	10091836	rev	G
		linear	0.X	±0.2								
			0.XX	±0.10								
			0.XXX	±0.050								
		angular	0°	±°								

# RIGHT WALL MODULE

SEE NOTE 8

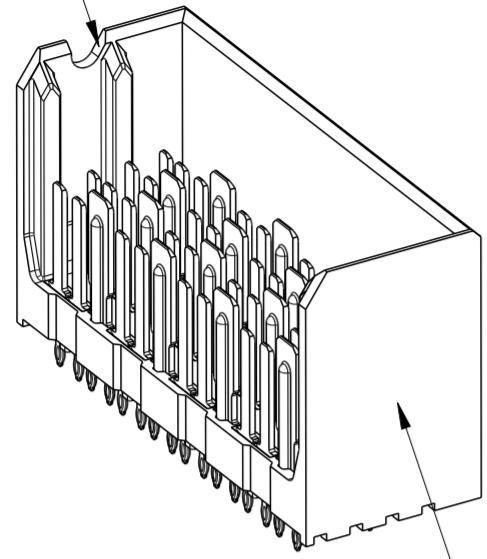

SEE NOTE 5

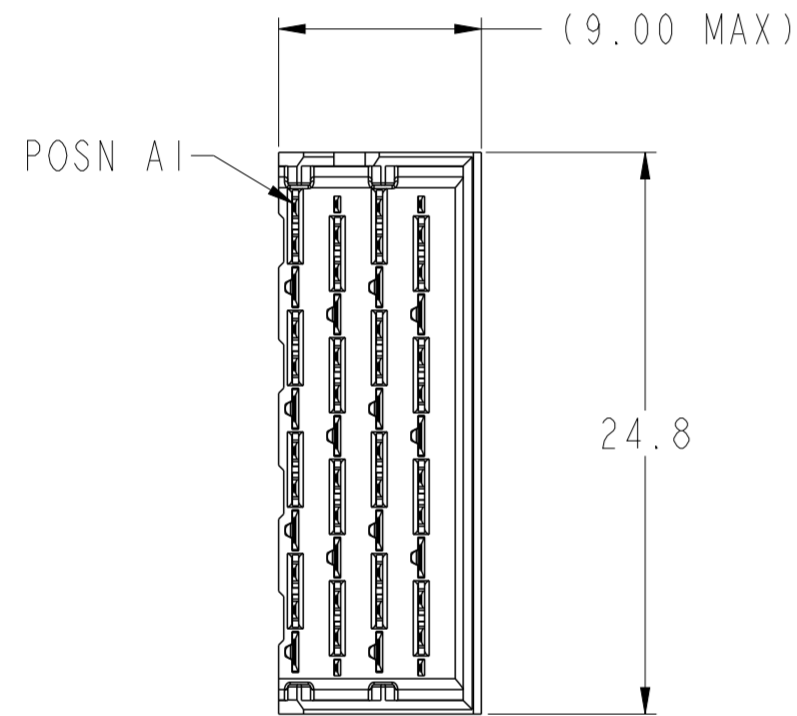

- 6.2 (4MM WIPE WIDE GROUNDS)
- 5.2 (3MM WIPE WIDE GROUNDS)
- 5.2 (3MM SMALL END GROUNDS)
- 5.2 (3MM WIPE SIGNALS)
- 4.2 (2MM WIPE SIGNALS)
- SEE P/N TREE

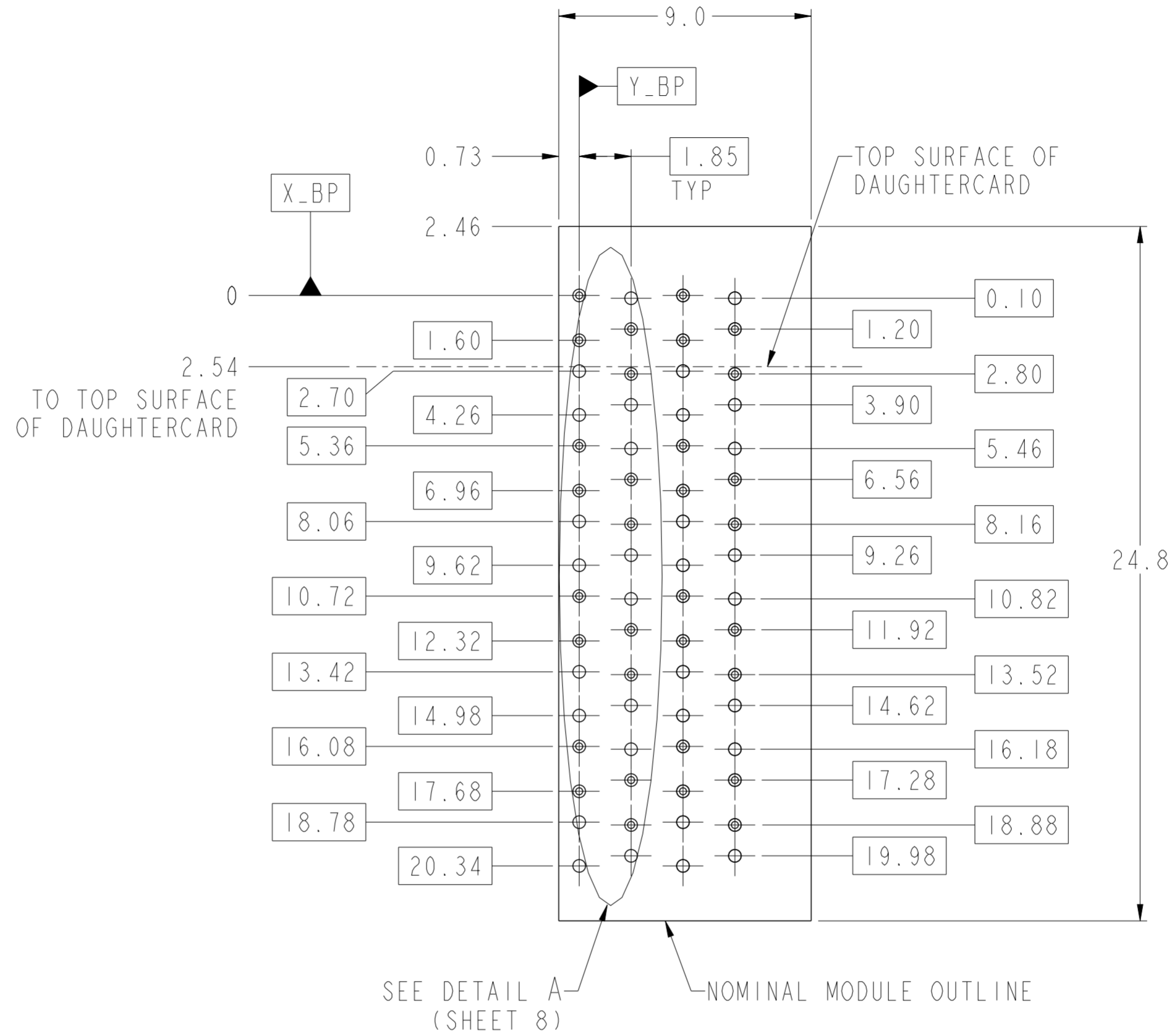
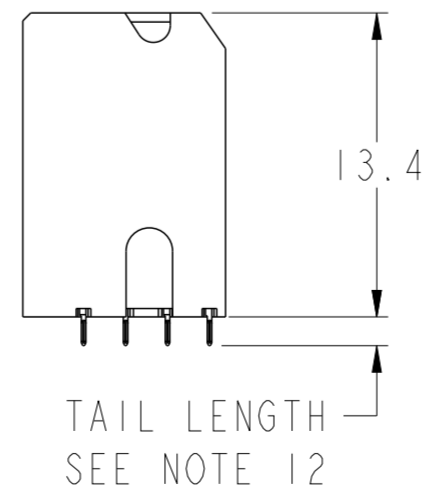
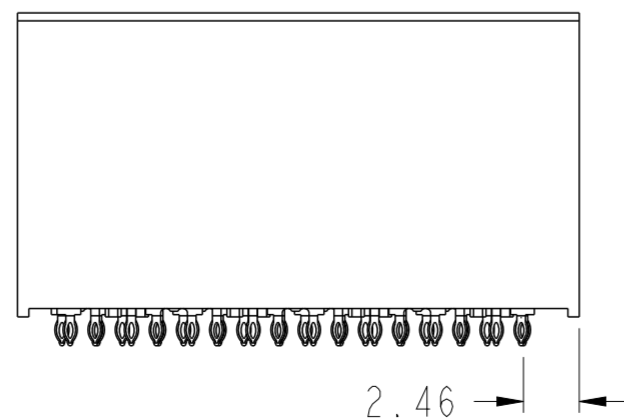
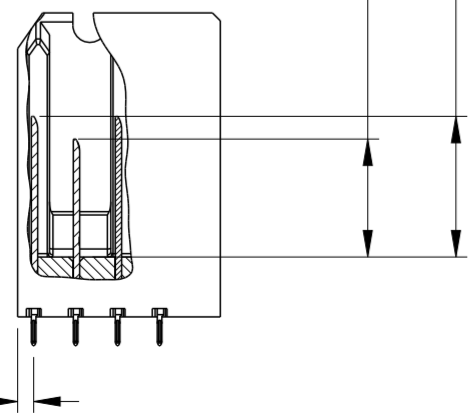

spec ref	SEE NOTES	dr	Jim Swain	2010/04/13	projection	MM	size	A2	scale	3:1
tolerance std	ASME Y14.5	eng	Michael Song	2016/06/06			ecn no	ELX-DG-24191-1		
TOLERANCES UNLESS OTHERWISE SPECIFIED		chr	Heaven Cen	2016/06/08			rel level	Released		
surface	linear	appr	Pai-Ming Zheng	2016/06/15	product family	XCede	rel level	Released		
ASME Y14.5	angular			<b>MODULE ASSEMBLY</b> VERTICAL HEADER, 4-COLUMN, 4-PAIR	dwg no	10091836			rev	G
		cat. no.	SEE P/N TREE	Product - Customer	Drw			sheet 6 of 8		

# 4-WALL MODULE

SEE NOTE 8

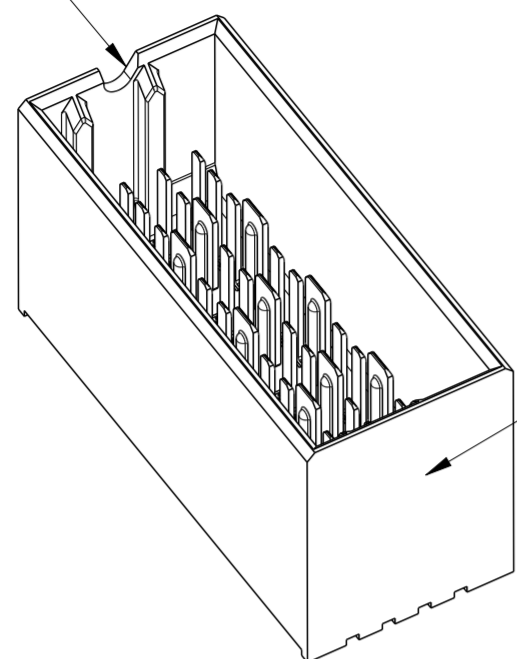

SEE NOTE 5

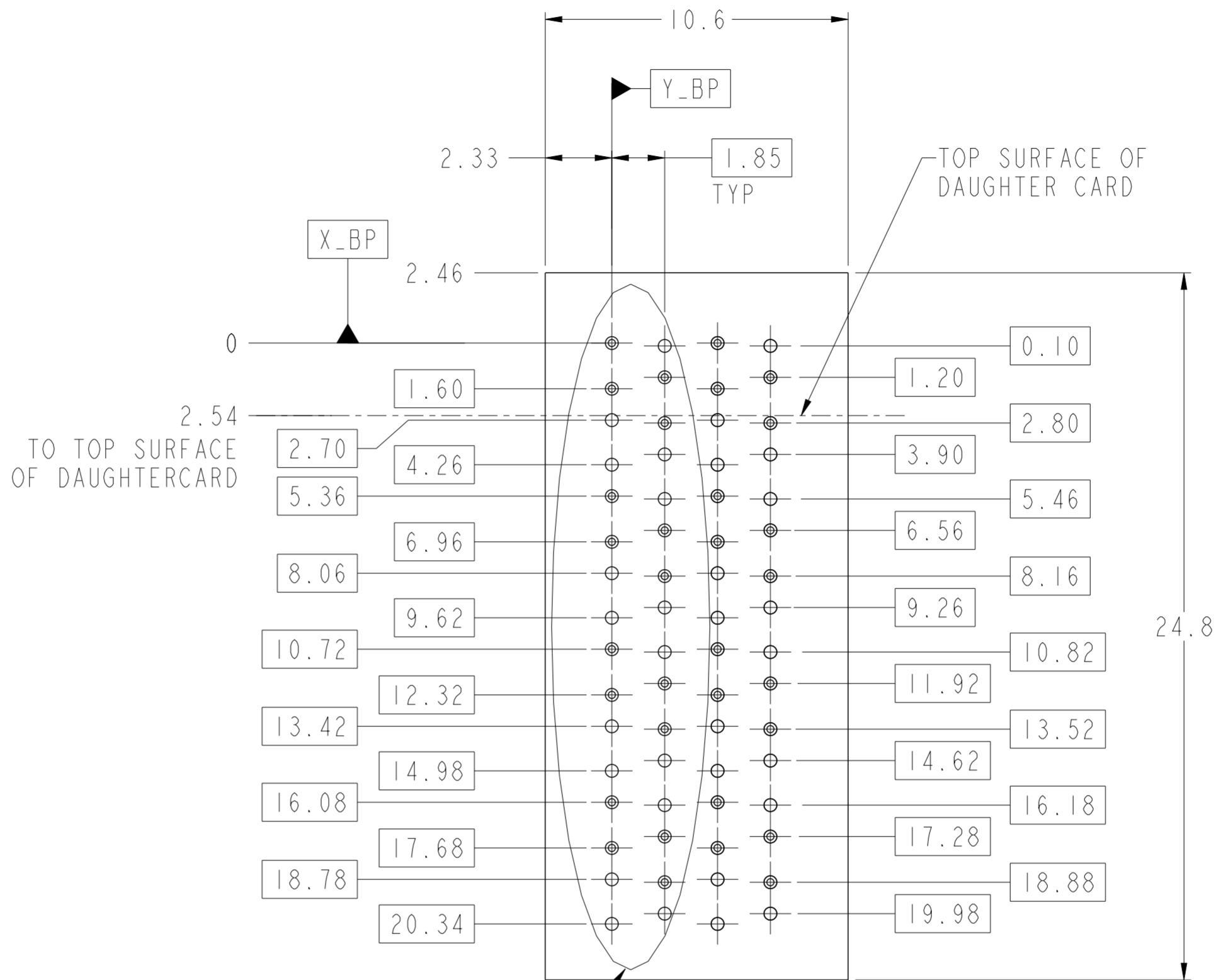

SEE DETAIL A (SHEET 8)

NOMINAL MODULE OUTLINE

PCB HOLE PATTERN  
COMPONENT SIDE  
SCALE 6:1

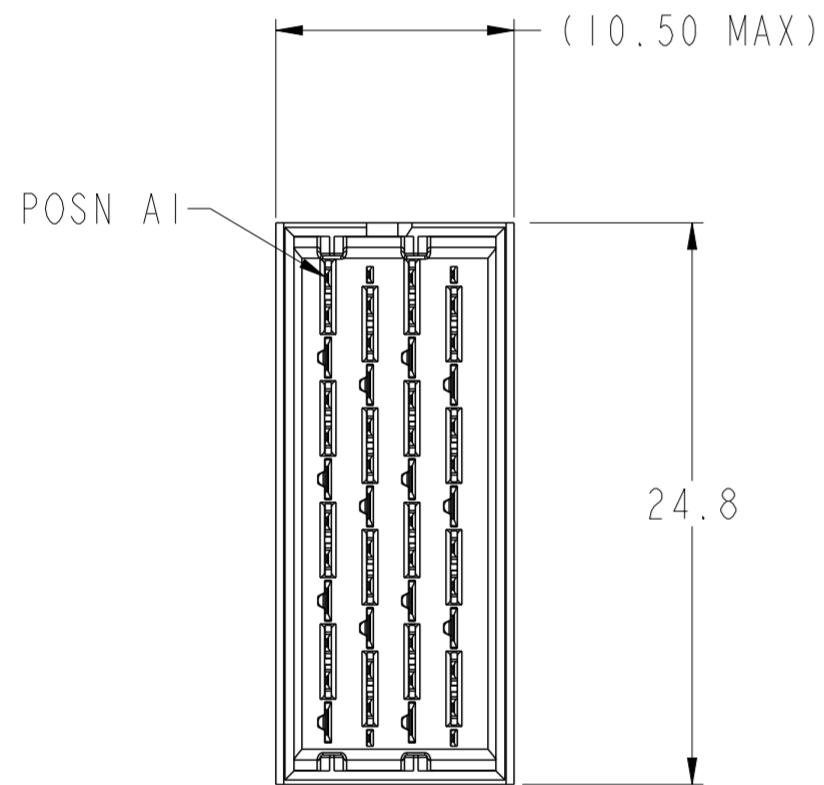

- 6.2 (4MM WIPE WIDE GROUNDS)
- 5.2 (3MM WIPE WIDE GROUNDS)
- 5.2 (3MM SMALL END GROUNDS)
- 5.2 (3MM WIPE SIGNALS)
- 4.2 (2MM WIPE SIGNALS)
- SEE P/N TREE

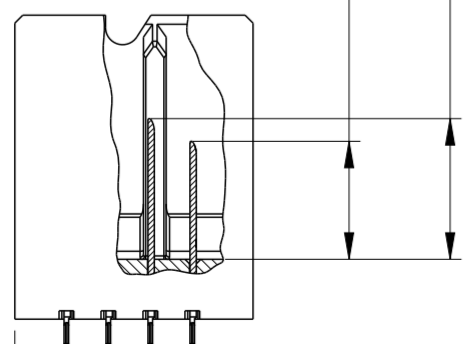

2.33

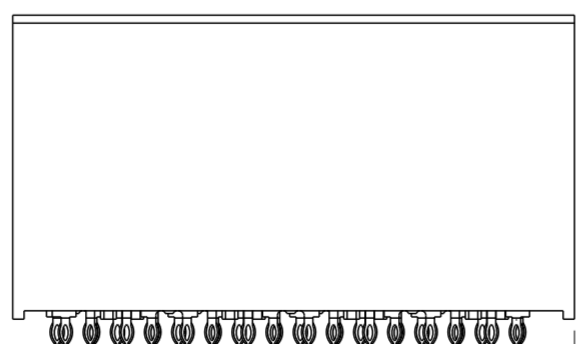

2.46

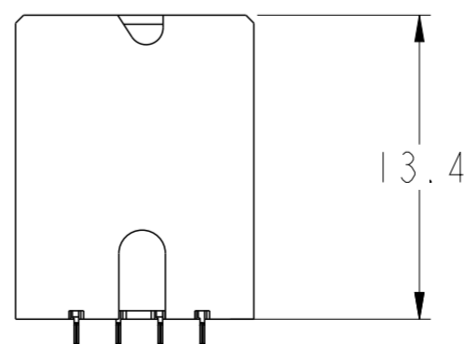

TAIL LENGTH  
SEE NOTE 12

spec ref	SEE NOTES	dr	Jim Swain	2010/04/13	projection	MM	size	A2	scale	4:1
tolerance std	ASME Y14.5	eng	Michael Song	2016/06/06			ecn no	ELX-DG-24191-1		
TOLERANCES UNLESS OTHERWISE SPECIFIED		chr	Heaven Cen	2016/06/08			rel level	Released		
surface	linear	0.X	±0.2		product family	-				
ASME Y14.5	0.XX	±0.10	<b>Amphenol FCI</b>		title	MODULE ASSEMBLY				
	0.XXX	±0.050			part no	10091836				
angular	0°	±°	cat. no.	-						
		Product - Customer Drw		sheet 7 of 8		rev		G		

NOTES:

1. CONNECTOR MATERIALS  
SHROUD: HIGH-TEMP THERMOPLASTIC, GRAY, UL94V-0  
CONTACTS: HIGH PERFORMANCE COPPER ALLOY
2. CONTACT PLATING:  
  
SEPARABLE INTERFACE: PERFORMANCE-BASED PLATING, QUALIFIED TO MEET THE REQUIREMENTS OF FCI PRODUCT SPECIFICATION GS-12-588, INCLUDING THE TELCORDIA GR-1217-CORE (NOVEMBER 1995) CENTRAL OFFICE (CO) OR UNCONTROLLED ENVIRONMENT (UE) TEST SEQUENCE AS NOTED IN P/N TREE.  
  
PRESS-FIT TAILS: TIN OVER NICKEL (LF), OR TIN-LEAD ALLOY OVER NICKEL (NON-LF). SEE P/N TREE.
3. PRODUCT SPECIFICATION: GS-12-588
4. APPLICATION SPECIFICATION: GS-20-121
5. PRODUCT MARKING (PART NUMBER AND LOT CODE) ON THESE SURFACES.
6. HOUSING MUST WITHSTAND EXPOSURE TO 260°C PEAK TEMPERATURE FOR 40 SECONDS IN A CONVECTION, INFRA-RED, OR VAPOR-PHASE REFLOW OVEN.
7. PACKAGING MEETS GS-14-920 LEAD-FREE LABELING SPECIFICATION.
8. NOTCH INDICATES "ROW A" SIDE OF CONNECTOR.
9. SEE APPLICATION SPECIFICATION FOR ROUTING GUIDELINES, ADDITIONAL PTH GUIDELINES, MATED DIMENSIONS, GUIDE PN SELECTION, ETC.
10. SCREW IS OPTIONAL AND ENGAGES WITH BOTTOM OF GUIDE-PIN FROM BENEATH THE PCB FOR ADDITIONAL GUIDE-PIN SUPPORT.
11. OPTIONAL HOLE LOCATION FOR GROUNDED PIN OR ADDITIONAL GUIDE-PIN SUPPORT. SEE TABLE 1 ON SHEET 1 FOR ADDITIONAL DETAILS.
12. TAIL LENGTH=1.3mm FOR  $\varnothing 0.55$ [0.0217"]COMPLIANT PIN DRILL  
TAIL LENGTH=1.5mm FOR  $\varnothing 0.45$ [0.0177"]COMPLIANT PIN DRILL

TABLE 3: PTH AND PAD SIZES WITH REFERENCE TO COMPLIANT PIN DRILL

COMPLIANT PIN DRILL	PTH	PAD
$\varnothing 0.55$ [0.0217"]	$\varnothing 0.45 \pm 0.05$	$\varnothing 0.85$
$\varnothing 0.45$ [0.0177"]	$\varnothing 0.36 \pm 0.05$	$\varnothing 0.75$

SEE TABLE 3 FOR PTH, DRILL & PAD SIZES

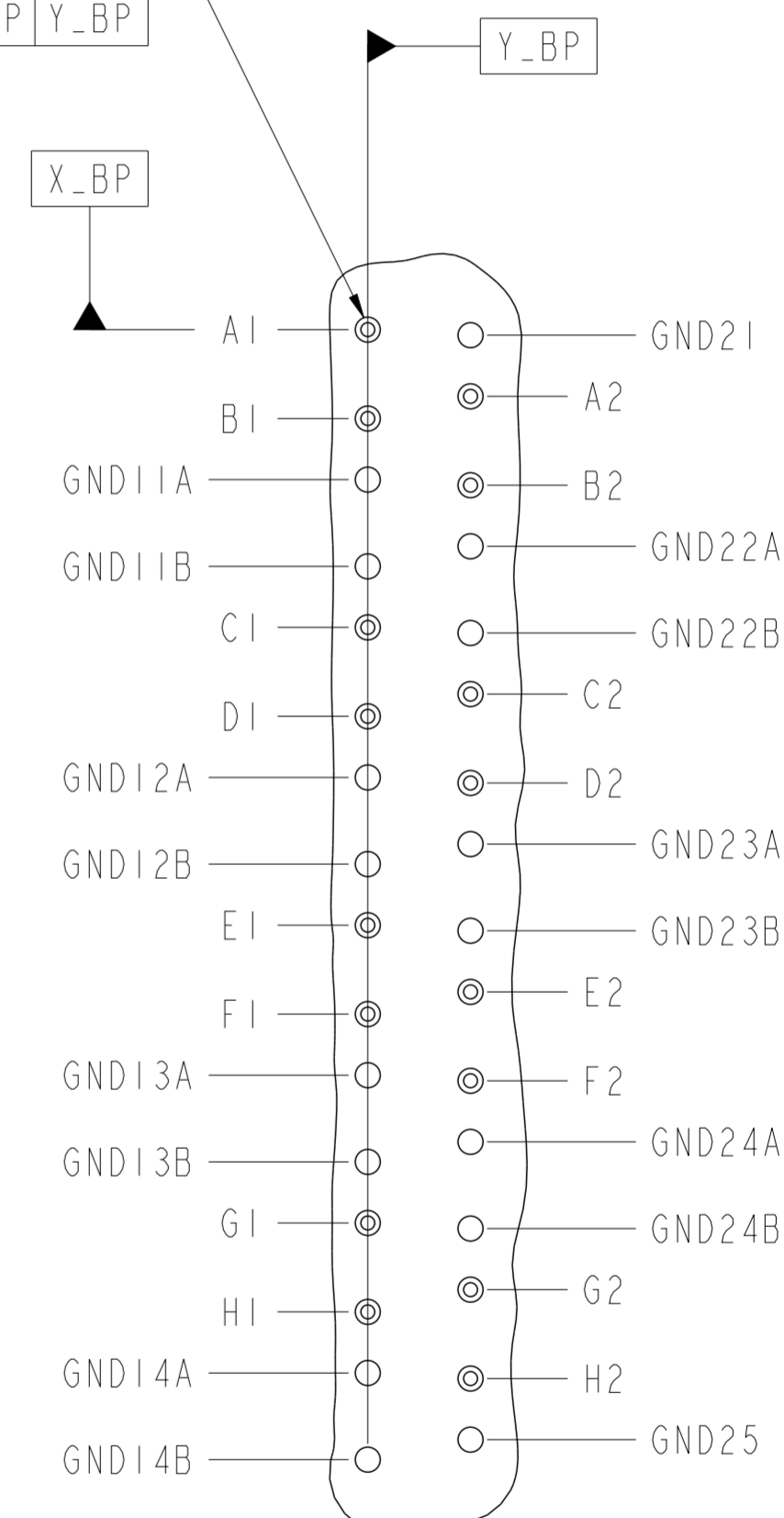

DETAIL A  
SCALE 8:1

Amphenol FCI

© 2016 APCI

spec ref	SEE NOTES	dr	Jim Swain	2010/04/13	projection	MM	size	A2	scale	4:1
tolerance std	TOLERANCES UNLESS OTHERWISE SPECIFIED	eng	Michael Song	2016/06/06			ecn no	ELX-DG-24191-1	rel level	Released
ASME Y14.5		chr	Heaven Cen	2016/06/08						
		appr	Pai-Ming Zheng	2016/06/15						
surface	linear	0.X	±0.2	<b>Amphenol FCI</b>		MODULE ASSEMBLY VERTICAL HEADER, 4-COLUMN, 4-PAIR		cat. no.	Product - Customer Drw	sheet 8 of 8
		0.XX	±0.10							
ASME Y14.5	angular	0.XXX	±0.050							
		0°	±°			cat. no.	Product - Customer Drw	sheet 8 of 8		

PDS: Rev :G

STATUS:Released

Printed: Jun 15, 2016